

**Illinois Tollway Base Sheet Revisions**

Section M		Base Sheet Drawings	
Drawing	Modification Summary	Effective: 03-01-2026	
<b>Plaza Electrical Work (Business System)-Series 2500</b>			
<b>M-BUS-2503</b>	<b>Single Line Power Diagram</b>		
Sheet 1	Revised size circuit breakers from 30A/2P to 50A/2P		
	Revised size circuit breakers 30A/1P to 30A/2P		
	Changed identification to ITS-1 Panel		
	Changed power cable type between main breaker service to Automatic transfer Switch: changed to cable Type 137		
	Updated single line diagram for MDP-1		
	Removed Line Conditioner identification on line diagram		
<b>M-BUS-2509</b>	<b>Exterior Elevations - Main Plaza</b>		
Sheet 1	Added a clearance of 18 in between HVAC 1 and HVAC 2		
<b>M-BUS-2510</b>	<b>Control Building Equipment Layout - Main Plaza</b>		
Sheet 1	Connected loose conduit to ITS Panel 1-2 ITS (Item 39)		
	Tag 38 was incorrectly identified as Tag 38 but shall be identified as Tag 37 as 5KVA transformer		
	Item 34 air compressor has been removed since there is a compressor to compress nitrogen gas into gas tank		
	Changed power cable type between main breaker service to Automatic transfer Switch: changed to cable Type 137		
	Revised legend for Item 19 to say: Free Standing UPS (4KVA)		
<b>M-BUS-2511</b>	<b>Interior Elevations - Control Building</b>		
Sheet 1	Added VES Wash cabinet		
	Revised representation of the four walls for clarity		
	Added representation for door, HVAC units, item 10, item 11 and item 28 for clarity		
	Revised description for Item 6 to say: Bypass Module		
	Revised description for Item 19 to say: Free Standing 4KVA UPS		
	Added description for Item # 33 and identified as : VES Wash Cabinet		
<b>M-BUS-2515</b>	<b>Panelboard Schedules - Main Plaza</b>		
Sheet 1	For MDP-1: revised loads for Phase A, Phase B and Phase C		
	Separated HVAC 1 and HVAC 2 with their respective loads for Phase A, Phase B and Phase C with 50A/2P breaker for each HVAC unit		
	Updated subtotal power values for Phase A, Phase B and Phase C		

**Illinois Tollway Base Sheet Revisions**

Section M		Base Sheet Drawings	
Drawing	Modification Summary	Effective: 03-01-2026	
<b>Plaza Electrical Work (Business System)-Series 2500</b>			
<b>M-BUS-2515</b>	<b>Panelboard Schedules - Main Plaza</b>		
<b>M-BUS-2516</b>	<b>Video Power Junction Box Detail - Main Plaza</b>		
Sheet 1	Revised Item 1 (at 2 locations on the drawing) enclosure model number: use Hoffman model # A-482408LE with white panel		
<b>M-BUS-2518A</b>	<b>Loop Plan - AET 3-Lane Layout</b>		
Sheet 1	Revised to add details for "Typical Termination of Spare Underground Conduit"		
<b>M-BUS-2518C</b>	<b>Loop Plan - AET 1-Lane Layout Single Monotube</b>		
Sheet 1	Drawing revised to show the installation details for a mounting box to be installed at the top of the vertical segment of the monotube		
	For VES Wash conduit: conduit to be one continuous piece when embedded - no splice allowed		
	Revised size of 1" to size 1 1/2" PVC coated RGS conduit		
<b>M-BUS-2518D</b>	<b>Ground Mounted VES Camera With VES Wash Tubing</b>		
Sheet 1	Added call out for 1 1/2" HDPE SDR-11 VES Was Tubing		
<b>M-BUS-2521</b>	<b>Control Building Equipment Layout - Remote Plaza</b>		
Sheet 1	Item 22: changed designation to Free Standing UPS (4KVA)		
	Item 31: air compressor removed		
	Item 23: changed designation to Not Used		
<b>M-BUS-2522</b>	<b>Interior Elevations - Remote Plaza</b>		
Sheet 1	Changed description for Item 22 to say: Free Standing UPS (4KVA)		
<b>M-BUS-2526</b>	<b>Panelboard Schedules - Remote Plaza AET Lanes</b>		
Sheet 1	Separated HVAC 1 and HVAC 2 with their respective loads for Phase A, Phase B and Phase C with 50A/2P breaker for each HVAC unit		
	Updated the total load for Phase A, Phase B and Phase C		
	Replaced spare breaker 30A/2 to 50A/2P		
	Updated subtotal power values for Phase A, Phase B and Phase C		
	Updated total load (Watts) for Phase A, Phase B and Phase C		
	For UPS-2 (Tolling and ITS) updated load to 2500w for Phase A and Phase C		

**Illinois Tollway Base Sheet Revisions**

<b>Section M</b>		<b>Base Sheet Drawings</b>	
<b>Drawing</b>	<b>Modification Summary</b>	<b>Effective: 03-01-2026</b>	
<b>Plaza Electrical Work (Business System)-Series 2500</b>			
<b>M-BUS-2527</b>	<b>Video Power Junction Box Detail - Remote Plaza</b>		
Sheet 1	Revised Item 1 enclosure model number: use Hoffman model # A-482408LE with white panel		
<b>M-BUS-2529</b>	<b>UPS Single Line and Wiring Diagram</b>		
Sheet 1	Added Note to Designer: Drawing now Reserved		
<b>M-BUS-2536A</b>	<b>Overhead Conduit Tray</b>		
Sheet 1	Added note to designer: Number and size of conduits to be determined by DSE		
<b>M-BUS-2536C</b>	<b>Underground Tolling Conduit Detail</b>		
Sheet 1	Show conduits details for the loops, AVI antenna cable, VES cameras power cable, VES camera data cable and VES Wash tubing		
<b>M-BUS-2536D</b>	<b>Control Building Junction Box Detail for Underground Conduit</b>		
Sheet 1	Details of the junction boxes attached to the plaza building with conduits sizes		
<b>M-BUS-2536E</b>	<b>Underground Conduit Elevation Installation Detail</b>		
Sheet 1	Lane loop junction box, conduits attached to barrier wall from approach monotube to departure monotube		
	Show conduits routing for VES cameras power and data, VES wash tubing		
	Show junction boxes for AVI/VES conduits, show junction boxes attached to monotubes		
<b>M-BUS-2536F</b>	<b>Duct Spacer Details</b>		
Sheet 1	Added spacer dimensions and installation details with location of tracer wire		
<b>M-BUS-2538</b>	<b>VES Wash System Single Cabinet Detail</b>		
Sheet 1	Description revised for Mark A to say: For indoor installation use Hammond enclosure model # HW603616SSHK. For outdoor installation use enclosure Hammond model # HWST603616SS		
<b>M-BUS-2539</b>	<b>VES Wash System Panel Detail</b>		
Sheet 1	Added sentence to Note 4: Contractor shall keep a 1 foot slack inside the VES wash enclosure for each of the VES Wash tubing when connected to the solenoid distribution		
	Revised Note 9 to replace the word Optional by a 500 Watt heater		

**Illinois Tollway Base Sheet Revisions**

<b>Section M</b>		<b>Base Sheet Drawings</b>	
<b>Drawing</b>	<b>Modification Summary</b>	<b>Effective: 03-01-2026</b>	
<b>Plaza Electrical Work (Business System)-Series 2500</b>			
<b>M-BUS-2539</b>	<b>VES Wash System Panel Detail</b>		
<b>M-BUS-2541</b>	<b>VES Wash System Suggested Conduit Routing</b>		
Sheet 1	Change size of VES conduit from 1" to 1 1/2" conduit at six locations on the sheet		



**New Sheet**

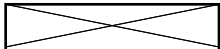

**Retired Standard**

CONDUIT SIZES	
①	RIGID METALLIC CONDUIT ¾"
②	RIGID METALLIC CONDUIT 1"
③	RIGID METALLIC CONDUIT 1¼"
④	RIGID METALLIC CONDUIT 1½"
⑤	RIGID METALLIC CONDUIT 2"
⑥	RIGID METALLIC CONDUIT 2½"
⑦	RIGID METALLIC CONDUIT 3"
⑨	RIGID METALLIC CONDUIT 4"
⑫	RIGID NON-METALLIC CONDUIT 1" SCHEDULE 40
⑮	RIGID NON-METALLIC CONDUIT 2" SCHEDULE 40
⑰	RIGID NON-METALLIC CONDUIT 3" SCHEDULE 40
⑱	NOT USED
⑲	RIGID NON-METALLIC CONDUIT 4" SCHEDULE 40
⑳	RIGID NON-METALLIC CONDUIT 1" SCHEDULE 80
㉒	RIGID NON-METALLIC CONDUIT 1½" SCHEDULE 80
㉔	RIGID NON-METALLIC CONDUIT 2" SCHEDULE 80
㉖	RIGID NON-METALLIC CONDUIT 3" SCHEDULE 80
㉘	RIGID NON-METALLIC CONDUIT 4" SCHEDULE 80
㉚	RIGID METALLIC CONDUIT PVC COATED 1"
㉜	RIGID METALLIC CONDUIT PVC COATED 1¼"
㉞	RIGID METALLIC CONDUIT PVC COATED 1½"
㉟	RIGID METALLIC CONDUIT PVC COATED 2"
㊱	RIGID METALLIC CONDUIT PVC COATED 3"
㊳	RIGID METALLIC CONDUIT PVC COATED 4"
㊵	1½" COILABLE PVC CABLE DUCT
㊷	RIGID NON-METALLIC CONDUIT 4" SCHEDULE 80 WITH 1" INNER DUCTS
㊹	1" COILABLE NON-METALLIC CONDUIT
㊻	2" COILABLE NON-METALLIC CONDUIT
㊽	4" COILABLE NON-METALLIC CONDUIT
㊿	3" COILABLE NON-METALLIC CONDUIT
46	1 ½" COILABLE NON-METALLIC CONDUIT

TOLL EQUIPMENT WIRING CABLE/CONDUIT SCHEDULE		
SYMBOL	CABLE DESCRIPTION	REMARKS
①	1-6PR #22 SHLD	NOTE 8
②	1-3/C #12 SHLD	NOTE 3
③	1-3PR #22 SHLD	NOTE 8
④	1-4/C #12 SHLD	NOTES 1 & 3
⑤	2-1/C #12, 1-1/C #12(GRD)	NOTE 1
⑥	1-1PR #14 SHLD (LOOP LEAD IN)	
⑦	1-1/C #14 (LOOP WIRE)	
⑧	1-1/C #6 BARE TINNED (GRD)	
⑨	1-7/C #12 SHLD	NOTE 3
⑩	1-3/C #12 SHLD	NOTE 3
⑪	2-1PR #22 SHLD	NOTE 1
⑫	1-2/C #12 SHLD	NOTE 3
⑬	1-2 PR #24 (RS 422)	NOTE 7
⑭	NOT USED	
⑮	1-COAXIAL ANTENNA CABLE	
⑯	1- 9/C #22 IND SHLD	
⑰	1-1/C #4/0 (GRD BARE TINNED COPPER CONDUCTOR)	
⑱	1-1/C #8 (GRD BARE TINNED COPPER CONDUCTOR)	
⑲	1-1/C #2 (GRD BARE TINNED COPPER CONDUCTOR)	
⑳	1-4PR #24 (CATEGORY 6)	
㉑	1-6 STRAND, SINGLE MODE FIBER OPTIC CABLE	ARMORED CABLE
㉒	1-24 STRAND, SINGLE MODE FIBER OPTIC CABLE	ARMORED CABLE
㉓	1-36 STRAND, SINGLE MODE FIBER OPTIC CABLE	ARMORED CABLE
㉔	1-48 STRAND, SINGLE MODE FIBER OPTIC CABLE	ARMORED CABLE
㉕	1-12PR #22 SHLD	
㉖	1-9/C #18 SHLD	NOTE 4
㉗	2-2/C #18 SHLD	NOTE 4
㉘	1-6PR #22 SHLD	
㉙	1-3PR #24 SHLD	NOTE 6
㉚	1-3/C #10 SHLD	
㉛	1-2PR #22 SHLD	
㉜	OEM CABLE (POWER AND VIDEO)	NOTE 10
㉝	1 - 1PR #22 SHLD (SENSE WIRE VES CAM)	
㉞ THRU ㉟	RESERVED FOR STANDARD DRAWINGS	
50	CAT6 CABLE	OUTDOOR RATED
51	SYNC CABLE, TWISTED PAIR # 24. BELDEN 89730	NOTE 11

TOLL EQUIPMENT WIRING CABLE/CONDUIT SCHEDULE				
SYMBOL	CABLE DESCRIPTION	CONDUIT SIZE		REMARKS
		EXPOSED	EMBEDDED OR UNDERGROUND	
101	(4) 1/C #3/0 (1) 1/C #4 (GRD)		4"	
102	(4) 1/C 250 MCM (1) 1/C #1/0 (GRD)		4"	
103	(4) 1/C #2 (1) 1/C #8 (GRD)		2"	
104	(3) 1/C #10 (1) 1/C #10 (GRD)	1"	1"	
105	(4) 1/C #10 (1) 1/C #10 (GRD)	1"	1"	
106	(2) 1/C #12 (1) 1/C #12 (GRD)	1"	1"	
107	(4) 1/C #12 (1) 1/C #12 (GRD)	1"	1"	
108	(4) 1/C #12 (1) 1/C #12 (GRD)	1"	1"	
109	(5) 1/C #12 (1) 1/C #12 (GRD)	1"	1"	
110	(5) 1/C #12 (1) 1/C #12 (GRD)	1"	2"	
111	(6) 1/C #12 (1) 1/C #12 (GRD)	1"	1"	
112	(8) 1/C #12 (1) 1/C #12 (GRD)	1"	1"	
113	1" CABLE DUCT WITH (2) 1/C #12 (1) 1/C #12 (GRD)	1"	1"	
114	1" CABLE DUCT WITH (3) 4/C #12 (SHLD)	1"	1"	
115	(3) 1/C #2/0 & 1 #8 (GND)		4"	
116	(2) 1/C #8 (1) 1/C #8 (GRD) 600V			
117	(3) 1/C #250MCM 600V (1) 1/C #1/0 (GRD) 600V		3"	
118	(2) 1/C #4 (1) 1/C #8 (GRD) 600V		2"	
119	(1) 16 AWG 6C FPLR (6) 1PR #22 SHLD	1"	1"	SECURITY-CARD ACCESS
120	(2) 1/C #16 SHIELDED PAIR	1"	1"	FIRE ALARM
121	(2) 1/C #10 (1) 1/C #10 (GRD)	1"	1"	
122	(3) 1/C #3/0 (1) 1/C #1/0 (GRD)		3"	
123	(3) 1/C #1/0 (1) 1/C #4 (GRD)		3"	
124	(1) 1/C #6 SHLD			NOTE 10
125	144 STRANDS SM, FIBER OPTIC			ARMORED CABLE
126	12 STRANDS SM, FIBER OPTIC			ARMORED CABLE
127	2#2, 1#6		2"	
128	2#1, 1#6		2"	
129	3#8, 1#8		2"	
130	2#6, 1#8		1¼"	

TOLL EQUIPMENT WIRING CABLE/CONDUIT SCHEDULE				
SYMBOL	CABLE DESCRIPTION	CONDUIT SIZE		REMARKS
		EXPOSED	EMBEDDED OR UNDERGROUND	
131	48 STRANDS SM. FIBER OPTIC			ARMORED CABLE
132	(3) 1/C #1 (1) 1/C #8 (GRD)			
133	(3) 1/C #2 (1) 1/C #8 (GRD)			
134	(3) 1/C #4 (1) 1/C #8 (GRD)			
135	(3) 1/C #12	1"	1"	
136	(4) 1/C 500 MCM (1) 1/C #1/0 (GRD)			
137	(4) 1/C 500 MCM (1) 1/C #4 (GRD)			

**NOTES:**

- MINIMUM SIZE OF EXPOSED CONDUIT IS ¾". MINIMUM SIZE OF EMBEDDED CONDUIT IS 1". EMBEDDED CONDUIT SHALL BE PVC COATED RIGID STEEL.
- STANDARD AND QUANTUM LOOPS SHALL BE FURNISHED AND INSTALLED BY THE ILLINOIS TOLLWAY. LOOP LEAD-IN CABLING IS FURNISHED AND INSTALLED BY THE CONTRACTOR.
- MULTI-CONDUCTOR SHIELDED CABLE #12 AWG FOR NORMAL AND UPS POWER, SHALL BE COLOR CODED AS SPECIFIED IN THE SPECIAL PROVISIONS OF THE CONTRACT.
- MULTI-CONDUCTOR SHIELDED CABLE #14 AWG THROUGH #18 AWG FOR CONTROL USE SHALL BE COLOR CODED PER ICEA-NEC (K-2) STANDARD.
- NOT USED
- PROVIDE SPD PROTECTION ADAPTERS FOR ALL ANTENNA CABLES ENTERING BUILDING. IN-LINE ADAPTERS MUST BE INSTALLED AT ALL CONNECTIONS TO THE RACK, ELPAC AND IPASS EQUIPMENT. THE SPD PROTECTION ADAPTERS SHALL BE PHOENIX CONTACT (OR EQUIVALENT) "COAXTRAX SERIES" CATALOG NUMBER C-UF8-5DC/E.
- PROVIDE SPD PROTECTION ADAPTERS FOR ALL RS-422 AND CATEGORY 6 CABLES ENTERING THE BUILDING. IN-LINE ADAPTERS MUST BE INSTALLED AT ALL CONNECTIONS TO THE CISCO SWITCH, ELPAC AND IPASS EQUIPMENT. THE SPD ADAPTER FOR RS-422 CABLES SHALL BE PHOENIX CONTACT (OR EQUIVALENT) DATATRAB D-UF8-V11/BS-B. THE SPD ADAPTER FOR CATEGORY 6 CABLES SHALL BE PHOENIX CONTACT (OR EQUIVALENT) DATATRAB D-LAN-CAT.6+.
- PLENUM RATED CABLE INSTALLED IN EMBEDDED CONDUIT.
- LANE VIOLATION CAMERA IS MOUNTED ON MONOTUBE.
- PROVIDE SURGE PROTECTION DEVICE FOR ALL CABLES FROM EXTERNAL DEVICES ROUTED INTO THE PLAZA BUILDING INCLUDING ALL CAT6, ANTENNA AND POWER CABLES.
- ANTENNA READER SYNC CABLE IN CONDUIT MUST BE INSTALLED BETWEEN TWO PLAZAS WHEN THEIR ANTENNAS ARE WITHIN 500FT. OF EACH OTHER.

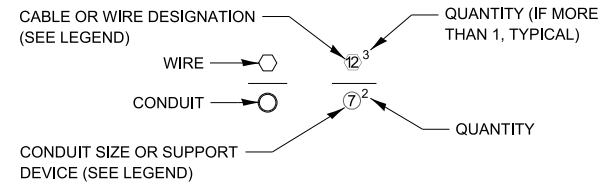

**NOTE TO DESIGNER**

THIS BASE SHEET SHOWS TYPICAL CONSTRUCTION BUT IT IS NOT A STANDARD DRAWING. IT REQUIRES COMPLETION BY THE DESIGNER PRIOR TO INSERTION INTO A CONTRACT. MICROSTATION FILES AND THE "CADD STANDARDS MANUAL" ARE AVAILABLE ON THE ILLINOIS TOLLWAY WEBSITE. THE DESIGNER SHALL ACCEPT THE RESPONSIBILITY OF THE DESIGN OF THIS SHEET UPON ITS COMPLETION AND INSERTION INTO A CONTRACT. ALL "NOTE TO DESIGNER" BOXES SHALL BE REMOVED BY THE DESIGNER PRIOR TO INSERTION OF THE SHEET INTO THE PLAN SET.

**CABLE / CONDUIT SCHEDULE AND GENERAL NOTES**

VERSION: 2021-03      BASE SHEET: M-BUS-2500      SHEET: 1 OF 1

**LEGEND**

	EXPOSED CONDUIT
	CONDUIT IN SLAB
	UNDERGROUND CONDUIT OR CABLE DUCT
	CONDUIT OR CABLE DUCT IN CASING
	HOME RUN TO PANEL AS NOTED
	INDICATES CIRCUIT TURNING DOWN
	INDICATES CIRCUIT TURNING UP
	GROUND ROD
	GROUNDING TRIAD
	EXPOSED GROUND CONDUCTOR
	UNDERGROUND GROUND CONDUCTOR
	4'X4' HEAVY DUTY HANDHOLE (POWER) EXISTING/PROPOSED
	4'X4' HEAVY DUTY HANDHOLE (COMMUNICATIONS) EXISTING/PROPOSED
	72"X48"X36" TORSION ASSIST FIBER HANDHOLE EXISTING/PROPOSED

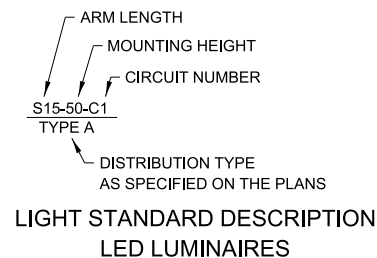

SYMBOL LIST	
SYMBOL	DESCRIPTION
	TRANSFORMER. 30 KVA DENOTES TRANSFORMER RATING. 480-208Y/120V DENOTES VOLTAGE. 3) DENOTES 3 PHASE. 4W DENOTES 4 WIRE.
	LEGEND NUMBER FOR CABLE & CONDUIT. (SEE CABLE AND CONDUIT SCHEDULES).
	MOTOR. NUMBER 1 DENOTES HORSEPOWER.
	AUTOMATIC TRANSFER SWITCH (ATS). N DENOTES NORMAL SOURCE. E DENOTES EMERGENCY SOURCE. L DENOTES LOAD. 260A DENOTES 260 AMPERE ATS RATING. 3P DENOTES 3 POLE. 4W DENOTES 4 WIRE.
	JUNCTION BOX.
	DISCONNECT SWITCH. 60A DENOTES 60 AMPERES.
	CIRCUIT BREAKER. 50A DENOTES 50 AMPERES.
	MANUAL TRANSFER SWITCH. 200A DENOTES 200 AMPERES. 3PDT DENOTES 3 POLE DOUBLE-THROW.
	SELF CONTAINED UTILITY METERING.
	STANDBY GENERATOR.
	PANEL CIRCUIT BREAKER. 30A DENOTES 30 AMPERES. 2P DENOTES 2 POLES.
	ELECTRICALLY HELD LIGHTING CONTACTOR.
	MECHANICALLY HELD LIGHTING COIL.
	CONTROL RELAY COIL.
	TRANSIENT VOLTAGE SURGE SUPPRESSION WITH LIGHTNING PROTECTION

ABBREVIATIONS	
ACM	AUTOMATIC COIN MACHINE
AET	ALL ELECTRONIC TOLL
AFF	ABOVE FINISH FLOOR
ATPM	AUTOMATIC TOLL PAYMENT MACHINE
ATS	AUTOMATIC TRANSFER SWITCH
AVI	AUTOMATED VEHICLE IDENTIFICATION
BF	BARRIER WARNING LIGHT
C/B	CIRCUIT BREAKER
CCTV	CLOSED CIRCUIT TELEVISION
CKT	CIRCUIT
CNC	COILABLE NON-METALLIC CONDUIT
DHH	DOUBLE HANDHOLE
FACP	FIRE ALARM CONTROL PANEL
FLPC	FRONT LICENSE PLATE CAMERA
GCS	GENERATOR CONTROL SWITCH
GFI	GROUND FAULT INTERRUPTER
HDPE	HIGH DENSITY POLYETHYLENE
HH	HANDHOLE
IPO	I-PASS ONLY
JB	JUNCTION BOX
LA	LIGHTNING ARRESTER
LC	LINE CONDITIONER
LCC	LANE CONTROLLER CABINET
LP	LIGHTNING PROTECTION
MCB	MAIN CIRCUIT BREAKER
MDP	MAIN DISTRIBUTION PANEL
MLO	MAIN LUG ONLY
MMF	MULTI-MODE FIBER
MSD	MAIN SERVICE DISCONNECT
MTS	MANUAL TRANSFER SWITCH
OCR	OPTICAL CHARACTER RECOGNITION
RLPC	REAR LICENSE PLATE CAMERA
SDR	STANDARD DIMENSION RATIO
SMF	SINGLE MODE FIBER
SPD	SURGE PROTECTION DEVICE
TOC	TRAFFIC OPERATION CENTER
TSIC	TERMINAL STRIP INTERCONNECT CENTER
UPS	UNINTERRUPTIBLE POWER SUPPLY
VES	VIOLATION ENFORCEMENT SYSTEM
WP	WEATHERPROOF

**NOTES:**

- ALL TYPE 'B' FIXTURES SHALL BE MOUNTED AT THE SAME ELEVATION WITH A MINIMUM MOUNTING HEIGHT AS INDICATED.

**NOTE TO DESIGNER**

THIS BASE SHEET SHOWS TYPICAL CONSTRUCTION BUT IT IS NOT A STANDARD DRAWING. IT REQUIRES COMPLETION BY THE DESIGNER PRIOR TO INSERTION INTO A CONTRACT. MICROSTATION FILES AND THE "CADD STANDARDS MANUAL" ARE AVAILABLE ON THE ILLINOIS TOLLWAY WEBSITE. THE DESIGNER SHALL ACCEPT THE RESPONSIBILITY OF THE DESIGN OF THIS SHEET UPON ITS COMPLETION AND INSERTION INTO A CONTRACT. ALL "NOTE TO DESIGNER" BOXES SHALL BE REMOVED BY THE DESIGNER PRIOR TO INSERTION OF THE SHEET INTO THE PLAN SET.

WIRING DEVICE SCHEDULE				
SYMBOL	DESCRIPTION	RATING	MFR. AND CAT. NO.	MOUNTING HEIGHT
	SINGLE-POLE SWITCH a-SWITCH LEG (LOWER CASE LETTER)	20A, 120V	HUBBELL #LHIR	4'-0"
	DUPLEX RECEPTACLE X - CIRCUIT NUMBER	20A, 120V	HUBBELL #HBL5362	18" AS NOTED
	QUAD RECEPTACLE X - CIRCUIT NUMBER	20A, 120V	(2) HUBBELL #HBL5362	18" AS NOTED
	4P, 4W, WEATHERPROOF RECEPTACLE WITH SPRING DOOR, BACK BOX, & ANGLE ADAPTER	200A, 600V	CROUSE-HINDS "ARKTITE" SERIES #AREA20417	3'-0" ABOVE GRADE
	4P, 4W, WEATHERPROOF RECEPTACLE WITH SPRING DOOR & BACK BOX	30A, 600V	CROUSE-HINDS "ARKTITE" SERIES #ARE3413	3'-0" ABOVE GRADE
	DUPLEX RECEPTACLE WITH GROUND FAULT PROTECTION WP - IDENTIFIES WEATHERPROOF	20A, 120V	HUBBELL #GF5362SG	3'-0" ABOVE GRADE
	3P, 3W, WEATHERPROOF RECEPTACLE	30A, 240V		3'-0" ABOVE GRADE

LIGHTING FIXTURE SCHEDULE					
SYMBOL	DESCRIPTION	VOLTAGE	LAMPS	MFR. AND CAT. NO.	REMARKS
	4' LED LOW PROFILE INDUSTRIAL LUMINAIRE	120 V	LED	H.E. WILLIAMS 96-4-L62/840-HIAFR-DRV-UNV	MOUNT 8' ABOVE FINISHED FLOOR
	LED LOW PROFILE WALL PACK	120 V	LED	H.E. WILLIAMS VWPV-L30/740-TFT-DBZ-CGL-DIM-UNV	MOUNT 10'-0" ABOVE FINISHED GRADE NOTE 1
	EMERGENCY LED LIGHT WITH NICKEL METAL HYBRIDE BATTERY	120 V	LED	H.E. WILLIAMS EMER/LED-WHT-SDT-D	MOUNT 8' ABOVE FINISHED FLOOR

**LEGEND AND SYMBOL LIST  
ABBREVIATIONS AND  
EQUIPMENT SCHEDULES**

VERSION: 2021-03      BASE SHEET: M-BUS-2501      SHEET: 1 OF 1

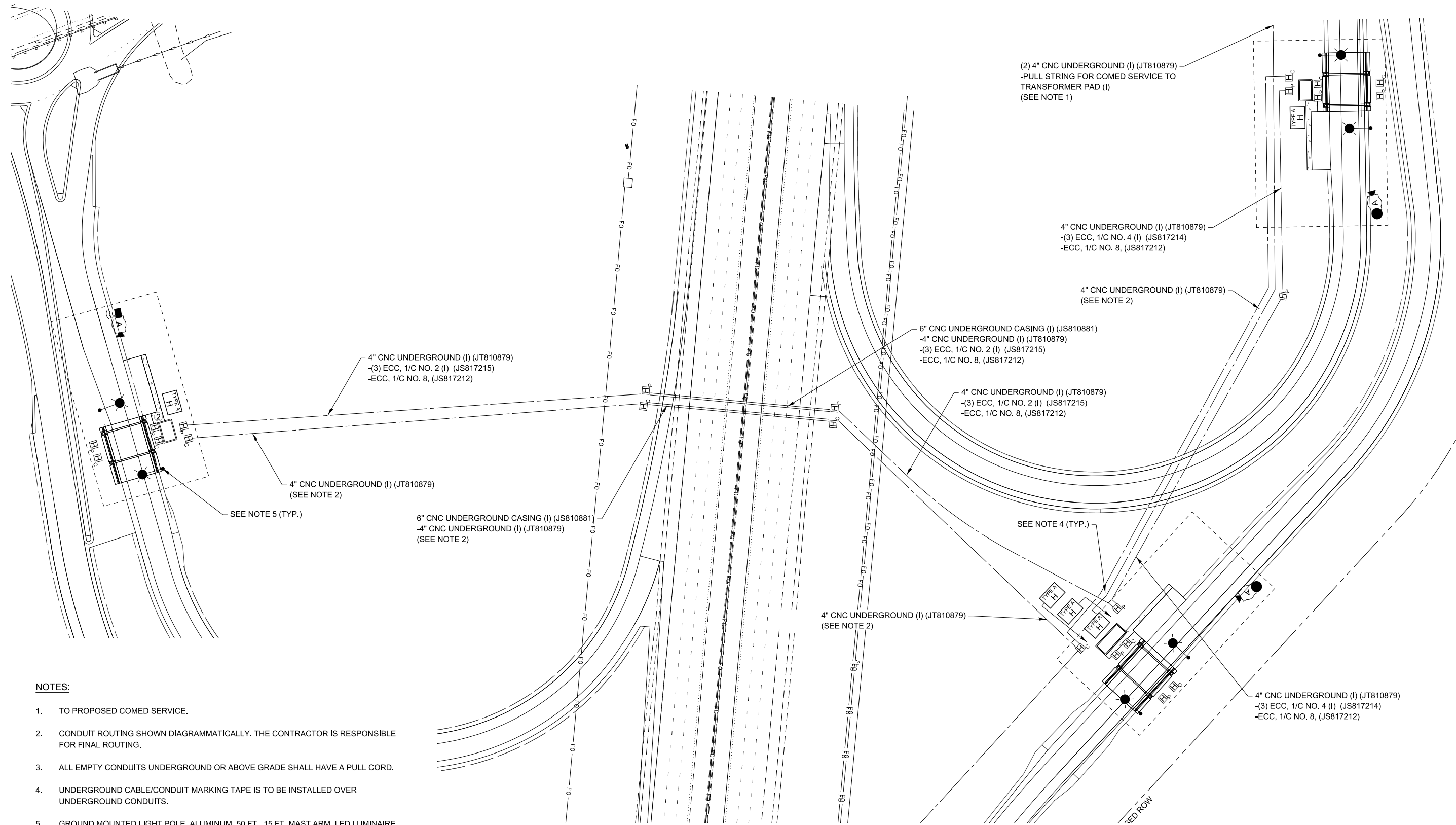

(2) 4" CNC UNDERGROUND (I) (JT810879)  
 -PULL STRING FOR COMED SERVICE TO  
 TRANSFORMER PAD (I)  
 (SEE NOTE 1)

4" CNC UNDERGROUND (I) (JT810879)  
 -(3) ECC, 1/C NO. 4 (I) (JS817214)  
 -ECC, 1/C NO. 8, (JS817212)

4" CNC UNDERGROUND (I) (JT810879)  
 (SEE NOTE 2)

6" CNC UNDERGROUND CASING (I) (JS810881)  
 -4" CNC UNDERGROUND (I) (JT810879)  
 -(3) ECC, 1/C NO. 2 (I) (JS817215)  
 -ECC, 1/C NO. 8, (JS817212)

4" CNC UNDERGROUND (I) (JT810879)  
 -(3) ECC, 1/C NO. 2 (I) (JS817215)  
 -ECC, 1/C NO. 8, (JS817212)

4" CNC UNDERGROUND (I) (JT810879)  
 -(3) ECC, 1/C NO. 2 (I) (JS817215)  
 -ECC, 1/C NO. 8, (JS817212)

4" CNC UNDERGROUND (I) (JT810879)  
 (SEE NOTE 2)

SEE NOTE 5 (TYP.)

6" CNC UNDERGROUND CASING (I) (JS810881)  
 -4" CNC UNDERGROUND (I) (JT810879)  
 (SEE NOTE 2)

SEE NOTE 4 (TYP.)

4" CNC UNDERGROUND (I) (JT810879)  
 (SEE NOTE 2)

4" CNC UNDERGROUND (I) (JT810879)  
 -(3) ECC, 1/C NO. 4 (I) (JS817214)  
 -ECC, 1/C NO. 8, (JS817212)

**NOTES:**

1. TO PROPOSED COMED SERVICE.
2. CONDUIT ROUTING SHOWN DIAGRAMMATICALLY. THE CONTRACTOR IS RESPONSIBLE FOR FINAL ROUTING.
3. ALL EMPTY CONDUITS UNDERGROUND OR ABOVE GRADE SHALL HAVE A PULL CORD.
4. UNDERGROUND CABLE/CONDUIT MARKING TAPE IS TO BE INSTALLED OVER UNDERGROUND CONDUITS.
5. GROUND MOUNTED LIGHT POLE, ALUMINUM, 50 FT., 15 FT. MAST ARM, LED LUMINAIRE (AS PER ROADWAY LIGHTING PLAN) AND LIGHT POLE FOUNDATION (ROADWAY) STEEL HELIX (7 FT) OR CONCRETE.
6. PROVIDE (2) 6" SDR 11 HDPE SLEEVES, EACH SLEEVE SHALL HAVE:
  - (1) 1 1/2" CNC DUCT (SOLID GREEN)
  - (1) 1 1/2" CNC DUCT (GREEN/WHITE STRIPE)
  - (1) 1 1/2" CNC DUCT (BLACK/RED STRIPE)

**NOTE TO DESIGNER**

THIS BASE SHEET SHOWS TYPICAL CONSTRUCTION BUT IT IS NOT A STANDARD DRAWING. IT REQUIRES COMPLETION BY THE DESIGNER PRIOR TO INSERTION INTO A CONTRACT. MICROSTATION FILES AND THE "CADD STANDARDS MANUAL" ARE AVAILABLE ON THE ILLINOIS TOLLWAY WEBSITE. THE DESIGNER SHALL ACCEPT THE RESPONSIBILITY OF THE DESIGN OF THIS SHEET UPON ITS COMPLETION AND INSERTION INTO A CONTRACT. ALL "NOTE TO DESIGNER" BOXES SHALL BE REMOVED BY THE DESIGNER PRIOR TO INSERTION OF THE SHEET INTO THE PLAN SET.



**ELECTRICAL SITE PLAN AET LANES**

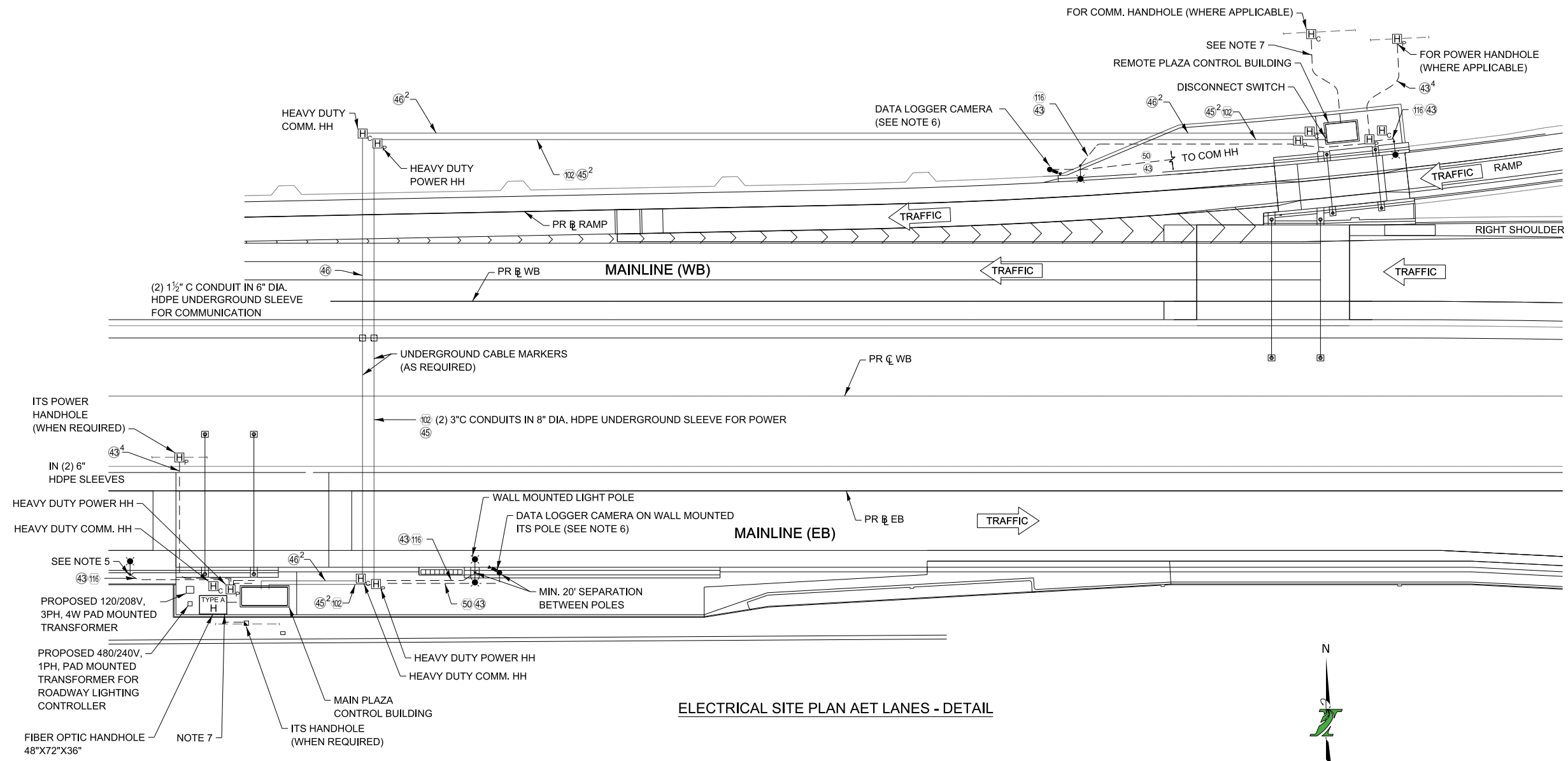

**ELECTRICAL SITE PLAN AET LANES - DETAIL**

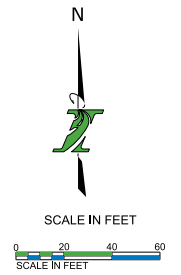

**NOTES:**

1. SEE LEGEND SHEET FOR SYMBOL LEGEND.
2. SEE CABLE/CONDUIT SCHEDULE SHEET FOR CABLE TAGS.
3. ALL EMPTY CONDUITS UNDERGROUND OR ABOVE GRADE SHALL HAVE A PULL CORD.
4. UNDERGROUND CABLE/CONDUIT MARKING TAPE IS TO BE INSTALLED OVER UNDERGROUND CONDUITS.
5. GROUND MOUNTED LIGHT POLE, ALUMINUM, 50 FT., 15 FT. MAST ARM, LED LUMINAIRE (AS PER ROADWAY LIGHTING PLAN) AND LIGHT POLE FOUNDATION (ROADWAY) STEEL HELIX (7 FT) OR CONCRETE.
6. DATA LOGGER CAMERA SHALL BE INSTALLED ON STEEL ITS POLE. SEE CAMERA DETAILS.
7. PROVIDE (2) 6" SDR 11 HDPE SLEEVES, EACH SLEEVE SHALL HAVE:  
 (1) 1 1/2" CNC DUCT (SOLID GREEN)  
 (1) 1 1/2" CNC DUCT (GREEN/WHITE STRIPE)  
 (1) 1 1/2" CNC DUCT (BLACK/RED STRIPE)

- NOTE TO DESIGNER**
1. THE DESIGNER MUST PROVIDE A CONTRACT SPECIFIC ELECTRICAL SITE PLAN. THIS DRAWING IS TO BE USED AS A GUIDE IN DEVELOPING THE CONTRACT ELECTRICAL SITE PLAN.
  2. THE POWER FEEDER MUST BE SIZED BY THE DESIGNER TO PROVIDE A MAXIMUM 3% VOLTAGE DROP.
  3. THE DESIGNER MUST PROVIDE PAY ITEMS, QUANTITIES AND UNIT BID PRICES FOR THE WORK SHOWN ON THIS DRAWING NOT INCLUDED IN THE PLAZA LUMP SUM PRICE.
  4. IF DISTANCE BETWEEN MAIN AND REMOTE PLAZA ANTENNAS IS LESS THAN 500 FT., PROVIDE CONDUIT AND SYNC CABLE TO CONNECT ANTENNA READERS IN THE MAIN AND REMOTE CONTROL BUILDINGS.
  5. MAIN AND REMOTE PLAZA BUILDING DOORS MUST FACE PAY ZONES.

- NOTE TO DESIGNER**
- THIS BASE SHEET SHOWS TYPICAL CONSTRUCTION BUT IT IS NOT A STANDARD DRAWING. IT REQUIRES COMPLETION BY THE DESIGNER PRIOR TO INSERTION INTO A CONTRACT. MICROSTATION FILES AND THE "CADD STANDARDS MANUAL" ARE AVAILABLE ON THE ILLINOIS TOLLWAY WEBSITE. THE DESIGNER SHALL ACCEPT THE RESPONSIBILITY OF THE DESIGN OF THIS SHEET UPON ITS COMPLETION AND INSERTION INTO A CONTRACT. ALL "NOTE TO DESIGNER" BOXES SHALL BE REMOVED BY THE DESIGNER PRIOR TO INSERTION OF THE SHEET INTO THE PLAN SET.

**ELECTRICAL SITE PLAN AET LANES - DETAIL**

VERSION: 2021-03	BASE SHEET: M-BUS-2502B	SHEET: 1 OF 1
---------------------	----------------------------	------------------

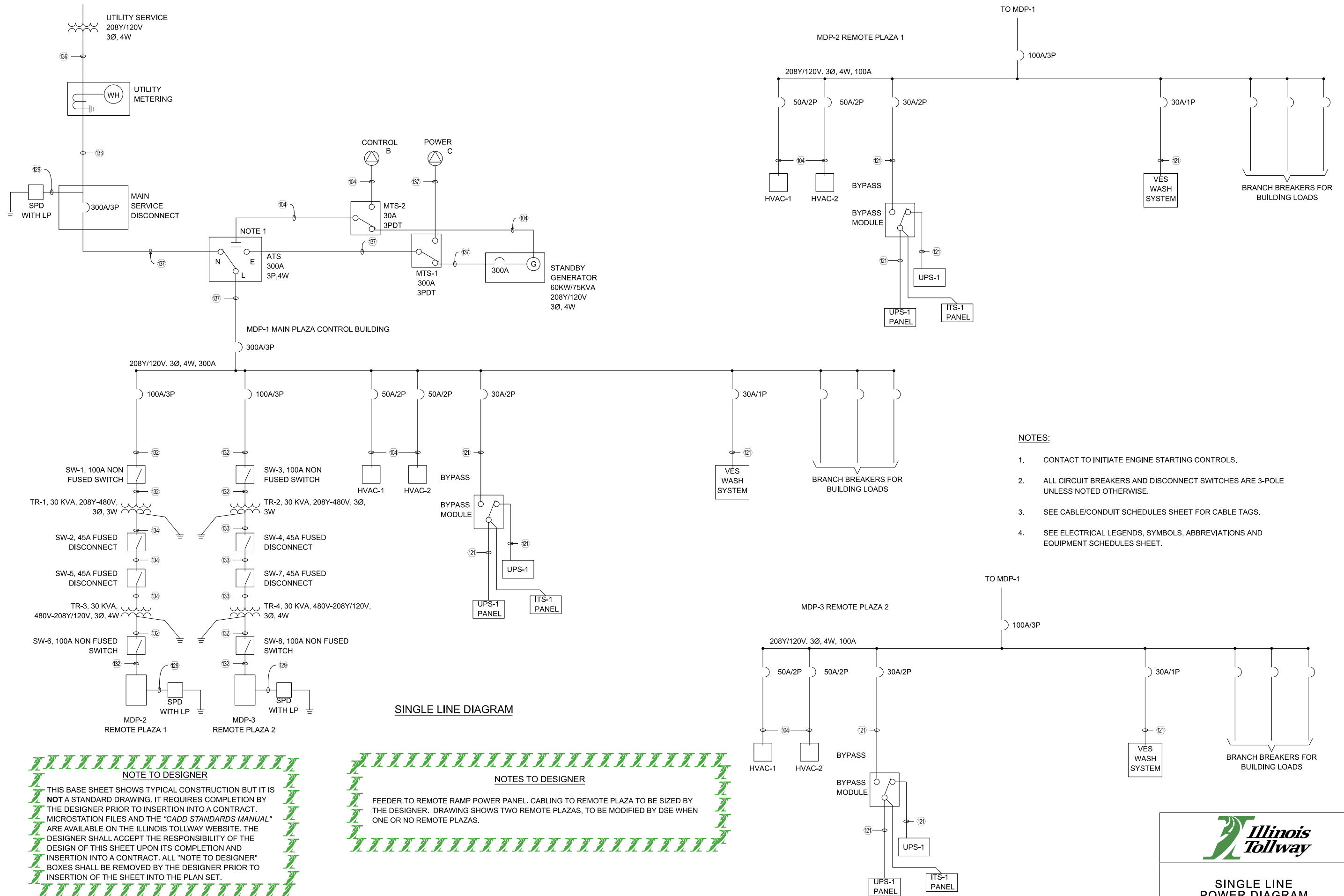

- NOTES:**
- CONTACT TO INITIATE ENGINE STARTING CONTROLS.
  - ALL CIRCUIT BREAKERS AND DISCONNECT SWITCHES ARE 3-POLE UNLESS NOTED OTHERWISE.
  - SEE CABLE/CONDUIT SCHEDULES SHEET FOR CABLE TAGS.
  - SEE ELECTRICAL LEGENDS, SYMBOLS, ABBREVIATIONS AND EQUIPMENT SCHEDULES SHEET.

**SINGLE LINE DIAGRAM**

**NOTE TO DESIGNER**

THIS BASE SHEET SHOWS TYPICAL CONSTRUCTION BUT IT IS NOT A STANDARD DRAWING. IT REQUIRES COMPLETION BY THE DESIGNER PRIOR TO INSERTION INTO A CONTRACT. MICROSTATION FILES AND THE "CADD STANDARDS MANUAL" ARE AVAILABLE ON THE ILLINOIS TOLLWAY WEBSITE. THE DESIGNER SHALL ACCEPT THE RESPONSIBILITY OF THE DESIGN OF THIS SHEET UPON ITS COMPLETION AND INSERTION INTO A CONTRACT. ALL "NOTE TO DESIGNER" BOXES SHALL BE REMOVED BY THE DESIGNER PRIOR TO INSERTION OF THE SHEET INTO THE PLAN SET.

**NOTES TO DESIGNER**

FEEDER TO REMOTE RAMP POWER PANEL. CABLING TO REMOTE PLAZA TO BE SIZED BY THE DESIGNER. DRAWING SHOWS TWO REMOTE PLAZAS, TO BE MODIFIED BY DSE WHEN ONE OR NO REMOTE PLAZAS.

**Illinois Tollway**

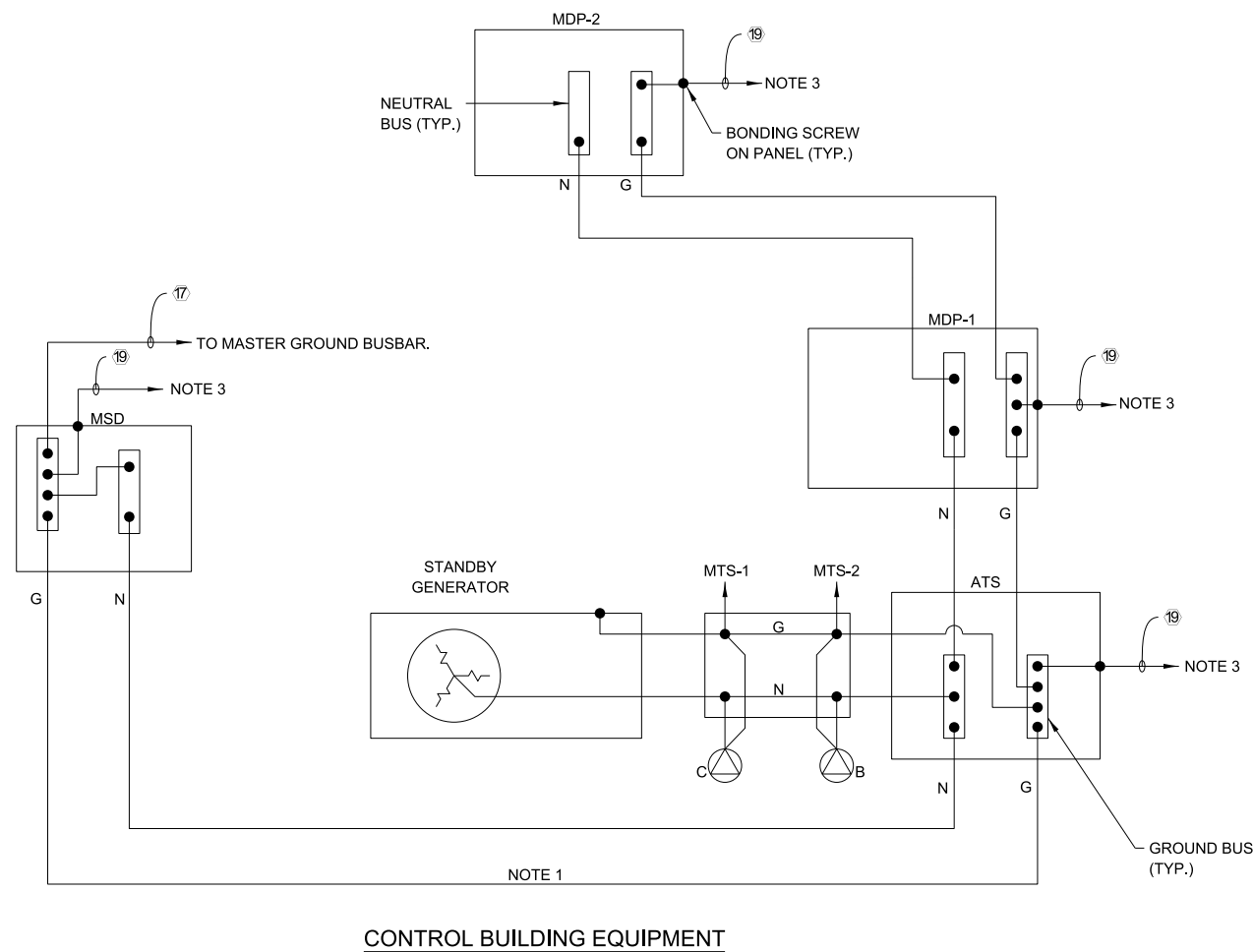

**SINGLE LINE POWER DIAGRAM**

VERSION: 2026-03      BASE SHEET: M-BUS-2503      SHEET: 1 OF 1



**NOTES:**

1. SEE CABLE/CONDUIT SCHEDULE SHEET FOR CABLE TAGS.
2. PROVIDE 3/4" SCHEDULE 40 PVC CONDUITS FOR GROUND CABLES CONNECTING UPS-1 AND LC-1 TO MASTER GROUND BUSBAR.
3. PROVIDE EXOTHERMIC CONNECTION TO INTERNAL PERIMETER BUS CONDUCTOR.
4. GROUNDING SHALL BE PER SPECIAL PROVISION.

  
**NOTE TO DESIGNER**
  

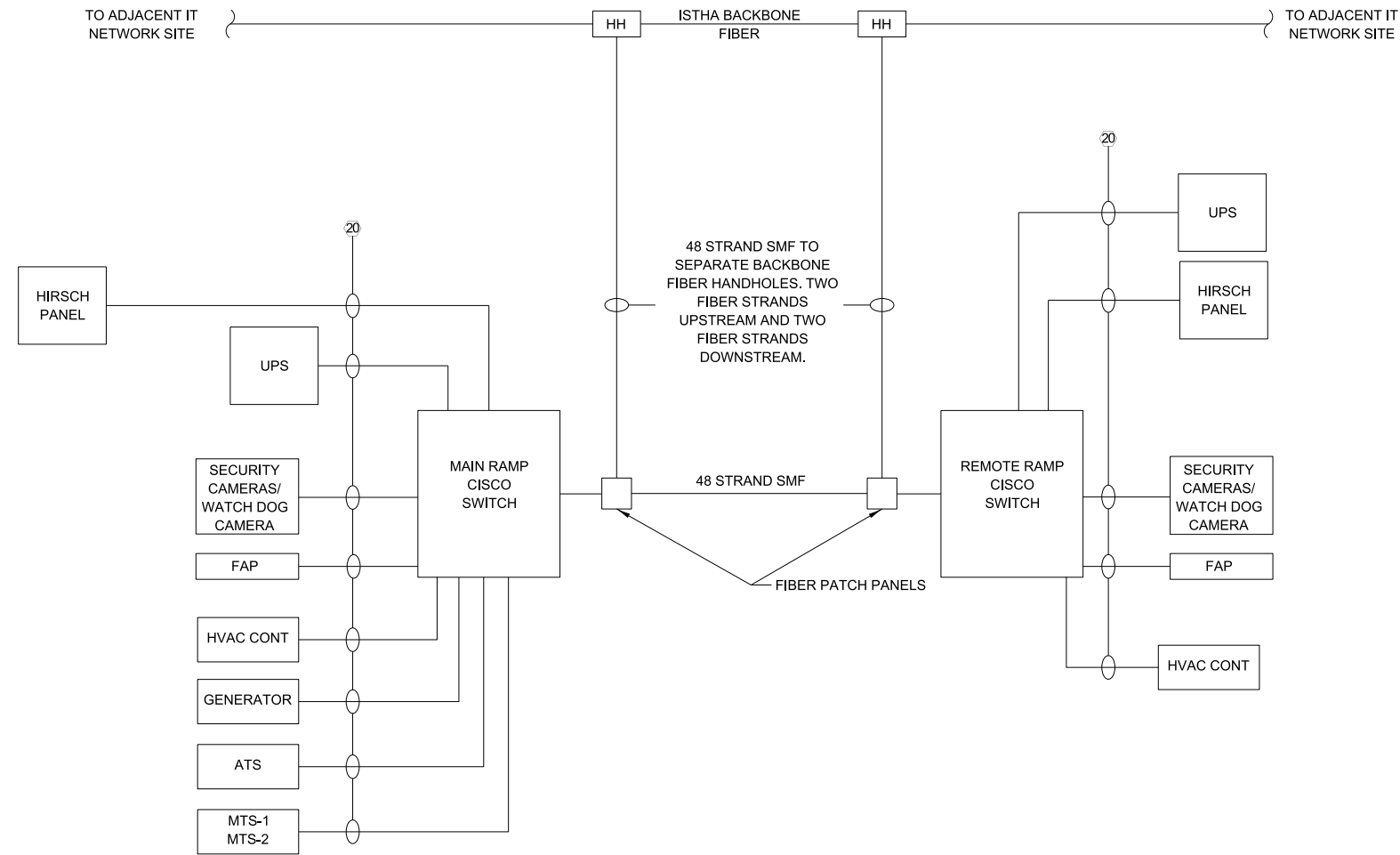
  
 THIS BASE SHEET SHOWS TYPICAL CONSTRUCTION BUT IT IS **NOT** A STANDARD DRAWING. IT REQUIRES COMPLETION BY THE DESIGNER PRIOR TO INSERTION INTO A CONTRACT. MICROSTATION FILES AND THE "CADD STANDARDS MANUAL" ARE AVAILABLE ON THE ILLINOIS TOLLWAY WEBSITE. THE DESIGNER SHALL ACCEPT THE RESPONSIBILITY OF THE DESIGN OF THIS SHEET UPON ITS COMPLETION AND INSERTION INTO A CONTRACT. ALL "NOTE TO DESIGNER" BOXES SHALL BE REMOVED BY THE DESIGNER PRIOR TO INSERTION OF THE SHEET INTO THE PLAN SET.
   



**SMF AND NETWORK CONNECTIVITY BETWEEN MAIN PLAZA AND REMOTE PLAZA**

**NOTES:**

1. EQUIPMENT SHOWN ON THIS DRAWING MUST BE COORDINATED WITH THE ILLINOIS TOLLWAY IT DEPARTMENT.
2. ALL CABLING AND CONNECTORS REQUIRED SHALL BE FURNISHED AND INSTALLED BY THE CONTRACTOR.
3. ALL FIBER OPTIC PATCH CORDS SHALL BE FURNISHED AND INSTALLED BY THE CONTRACTOR.
4. ALL FIBER OPTIC SFP'S REQUIRED FOR TERMINATING FIBER OPTIC CABLES AT CISCO SWITCHES SHALL BE FURNISHED AND INSTALLED BY THE CONTRACTOR.
5. PROVIDE IN-LINE SPD PROTECTION ADAPTERS FOR ALL CATEGORY 6 CABLES ENTERING THE BUILDING INCLUDING ALL CONNECTIONS TO THE CISCO SWITCH, EPAC, I-PASS EQUIPMENT AND RACK.

**NOTE TO DESIGNER**

WHETHER A RAMP PLAZA BUILDING CONNECTS TO THE FIBER BACKBONE DIRECTLY OR THROUGH A MAIN CONTROL BUILDING IS SITUATIONAL BASED ON THE NUMBER OF BUILDINGS, DISTANCE BETWEEN THEM, AND OTHER FACTORS. DETERMINE FIBER ROUTING IN COORDINATION WITH ILLINOIS TOLLWAY I.T. AND BUSINESS SYSTEMS.

**NOTE TO DESIGNER**

THIS BASE SHEET SHOWS TYPICAL CONSTRUCTION BUT IT IS NOT A STANDARD DRAWING. IT REQUIRES COMPLETION BY THE DESIGNER PRIOR TO INSERTION INTO A CONTRACT. MICROSTATION FILES AND THE "CADD STANDARDS MANUAL" ARE AVAILABLE ON THE ILLINOIS TOLLWAY WEBSITE. THE DESIGNER SHALL ACCEPT THE RESPONSIBILITY OF THE DESIGN OF THIS SHEET UPON ITS COMPLETION AND INSERTION INTO A CONTRACT. ALL "NOTE TO DESIGNER" BOXES SHALL BE REMOVED BY THE DESIGNER PRIOR TO INSERTION OF THE SHEET INTO THE PLAN SET.

**NOTES**

1. SEE CABLE AND CONDUIT SCHEDULE SHEET FOR CABLE TAGS.
2. SEE AET WIRING DIAGRAM SHEET FOR MONOTUBE WIRING.
3. CAP ALL CONDUIT STUBS FOR FUTURE USE.
4. FINAL LOCATION OF ALL HANDHOLES AND JUNCTION BOXES SHALL BE APPROVED BY THE ENGINEER.
5. NOT USED.
6. ROUTE PLAZA ROADWAY LIGHTING CIRCUITS TO LIGHTING CONTACTOR. THESE STAY ON PLAZA CIRCUITS, THAT ARE POWERED FROM PLAZA EMERGENCY GENERATOR. ROUTE 2-1/C #8 AND 1/C #8 GROUND WIRE FROM LIGHTING CONTACTOR LOCATED IN THE POWER CABINET TO THE LIGHT POLE FOR PLAZA LIGHTING CONTROL CIRCUIT. PROVIDE PHOTOCELL ON SAME POLE.
7. ALL EXCESS (SLACK) POWER AND DATA CABLES MUST BE COILED IN THE HANDHOLE. NO EXCESS CABLE WILL BE COILED INSIDE THE BUILDING.
8. EXOTHERMICALLY WELD THE GROUND WIRE TO THE MONOTUBE'S BASE.
9. REFER TO TSIC TERMINAL BLOCK LAYOUT SHEET. LOW VOLTAGE WIRE FROM VES AND SECURITY CAMERAS LAND ON SURGE PROTECTION DEVICES.
10. PVC CONDUIT SHALL BE USED WHEN THE CONDUIT IS EITHER COVERED OR ENCASED IN CONCRETE. ANY EXPOSED CONDUIT SHALL BE PVC COATED RGS. SLEEVES SHALL BE USED WHEN CROSSING WALL FOUNDATIONS.
11. LOCATION OF LANE STUB UPS TO BE APPROVED BY THE ILLINOIS TOLLWAY PRIOR TO CONCRETE POUR. FINAL LOCATION OF EQUIPMENT TO BE APPROVED BY THE ENGINEER.
12. PROVIDE (2) 4" PVC COATED RGS 5FT PAST RETAINING WALL UP TO ComEd TRANSFORMER FOR ComEd INCOMING PRIMARY CABLES. INSTALL SLEEVE IN COORDINATION WITH STRUCTURAL AND STUB UP NEAR ComEd TRANSFORMER LOCATION. PROVIDE WATER PROOF SEALING AT RETAINING WALL.
13. NOT USED.
14. CONTRACTOR SHALL FURNISH AND INSTALL PROPOSED TRANSFORMER PAD AND CONDUIT/TRENCH FOR ComEd. ComEd WILL FURNISH AND INSTALL TRANSFORMER AND GROUND ROD/WIRING. ALL WORK SHALL CONFORM TO ComEd STANDARD. THIS WILL BE PAID UNDER PAY ITEM: JS804100 - ELECTRIC SERVICE INSTALLATION.
15. SEE VES CAMERA WASH SYSTEM SHEETS FOR DETAILS.
16. FOR LIGHT POLE AND FOUNDATION DETAILS, SEE ILLINOIS TOLLWAY STANDARD DRAWINGS H1 AND H2.
17. CONTRACTOR SHALL PROVIDE (1) 4" PVC COATED RGS SLEEVE FROM BUILDING SOUTHEAST CORNER SOUTH UP TO NICOR METER PAD TO INSTALL GAS PIPING TO BUILDING. STUB UP SLEEVE NEAR GAS METER LOCATION. PROVIDE WATERPROOF SEALING AT RETAINING WALL.
18. RIGID METALLIC CONDUIT PVC COATED FOR MONOTUBE POWER/DATA/ANTENNA CABLING SHALL RUN IN OVERHEAD CONDUIT TRAY. SEE OVERHEAD CONDUIT TRAY DETAILS.
19. PROVIDE (2) 6" SDR 11 HDPE SLEEVES, EACH SLEEVE SHALL HAVE:  
 (1) 1 1/2" CNC DUCT (SOLID GREEN)  
 (1) 1 1/2" CNC DUCT (GREEN/WHITE STRIPE)  
 (1) 1 1/2" CNC DUCT (BLACK/RED STRIPE)
20. PROVIDE LIGHTING CONTROLLER SERVICE CONDUIT 3" PVC-SCH 40 AND STUP UP INTO METER 3" RGS PVC COATED FOR SERVICE TO THE CONTROLLER.

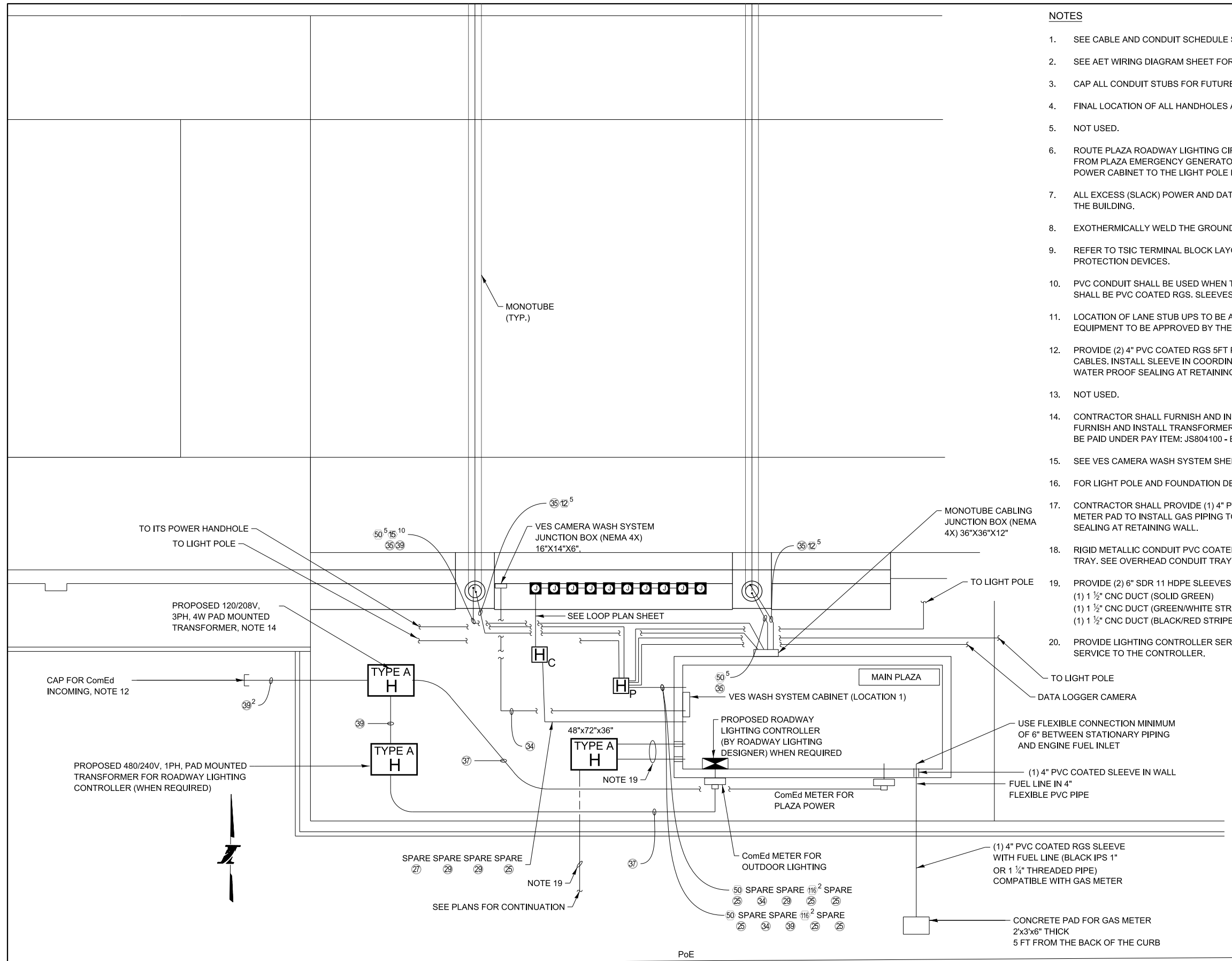

**NOTE TO DESIGNER**

THIS BASE SHEET SHOWS TYPICAL CONSTRUCTION BUT IT IS **NOT** A STANDARD DRAWING. IT REQUIRES COMPLETION BY THE DESIGNER PRIOR TO INSERTION INTO A CONTRACT. MICROSTATION FILES AND THE "CADD STANDARDS MANUAL" ARE AVAILABLE ON THE ILLINOIS TOLLWAY WEBSITE. THE DESIGNER SHALL ACCEPT THE RESPONSIBILITY OF THE DESIGN OF THIS SHEET UPON ITS COMPLETION AND INSERTION INTO A CONTRACT. ALL "NOTE TO DESIGNER" BOXES SHALL BE REMOVED BY THE DESIGNER PRIOR TO INSERTION OF THE SHEET INTO THE PLAN SET.

**UNDERGROUND CONDUIT PLAN MAIN PLAZA**



**UNDERGROUND CONDUIT PLAN - MAIN PLAZA**

VERSION: 2021-03	BASE SHEET: M-BUS-2506	SHEET: 1 OF 1
---------------------	---------------------------	------------------

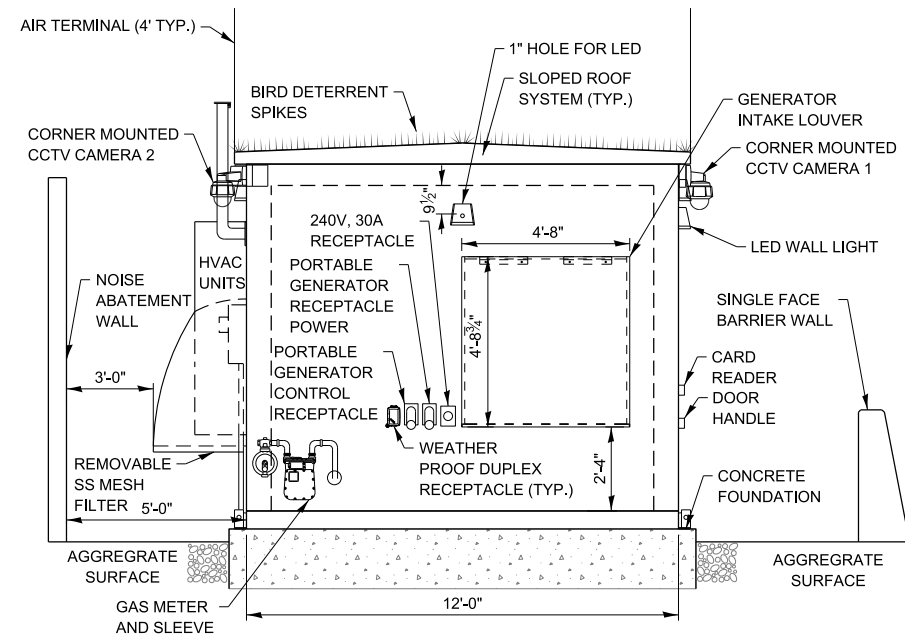

SECTION A-A

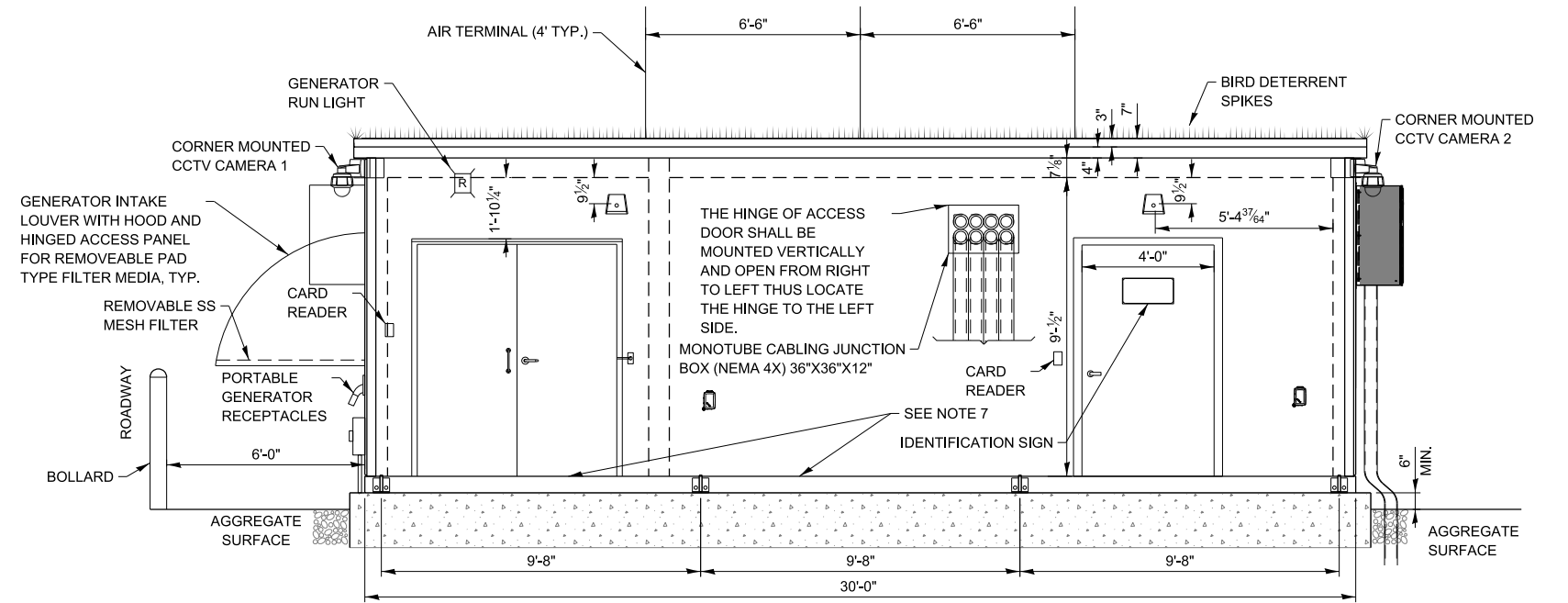

SECTION C-C

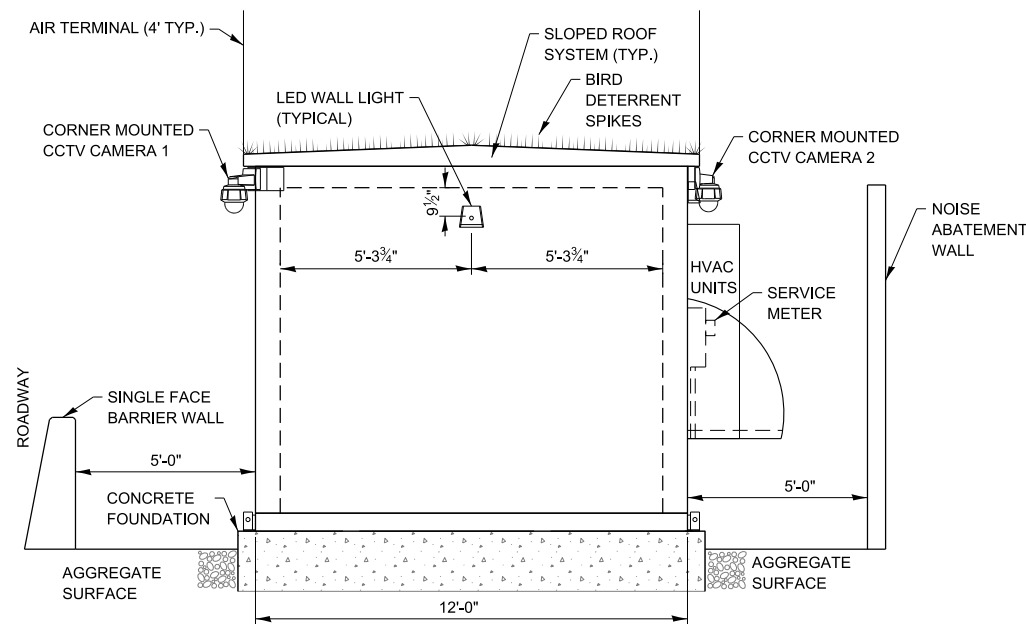

SECTION B-B

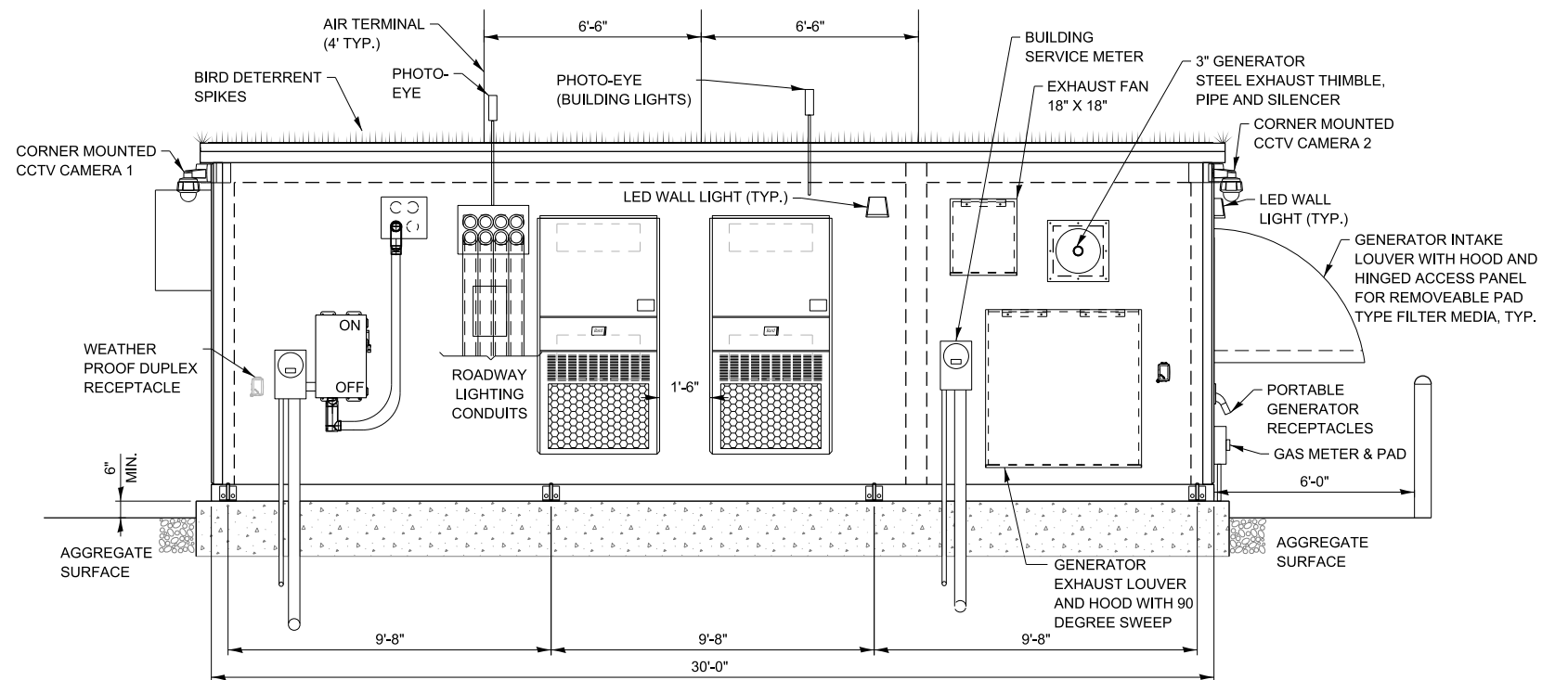

SECTION D-D

**NOTE TO DESIGNER:**

AIR TERMINAL RODS ARE TO BE INSTALLED AND FIXED TO ROOF WITHOUT INTERFERING WITH THE INTEGRITY OF THE STRUCTURE

**NOTES:**

- TREAD RISERS SHALL BE EQUAL AND NO GREATER THAN 7".
- BOND BASE OF BIRD SPIKE ASSEMBLY TO GROUNDING CONDUCTOR FOR THE LIGHTNING PROTECTION SYSTEM.
- CONNECT CABLE TO NEAREST GROUND ROD ON THE BUILDING GROUND GRID.



EXTERIOR ELEVATIONS - MAIN PLAZA

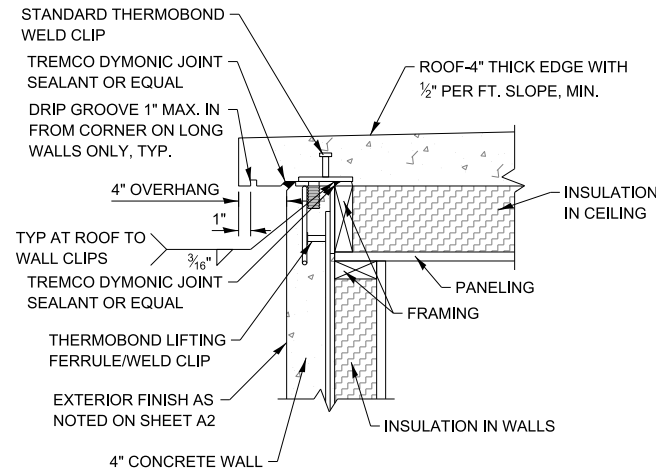

**ROOF TO WALL SECTION**

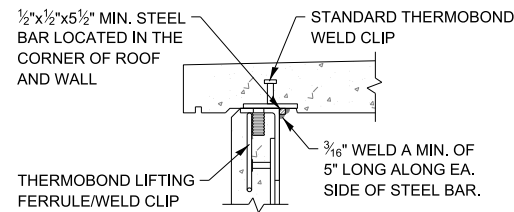

**ROOF TO WALL WELD**

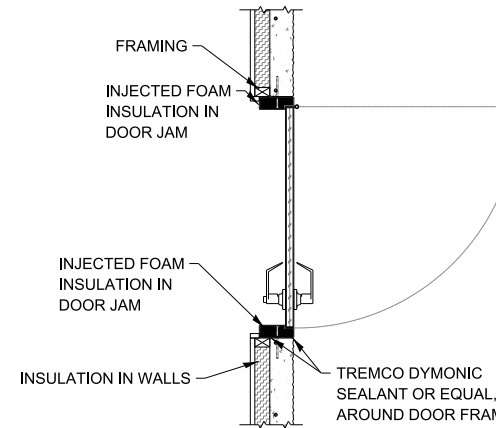

**TYPICAL DOOR SECTION DETAIL**

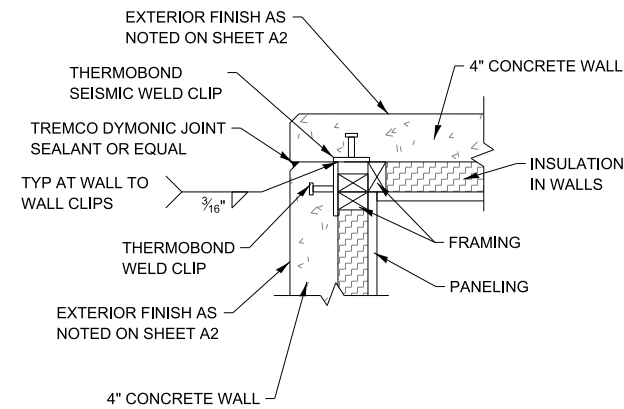

**WALL TO WALL SECTION**

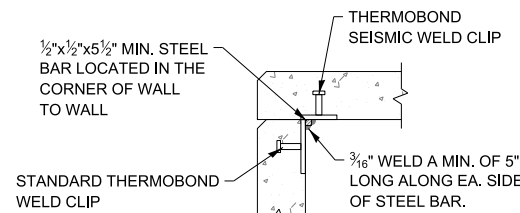

**WALL TO WALL WELD**

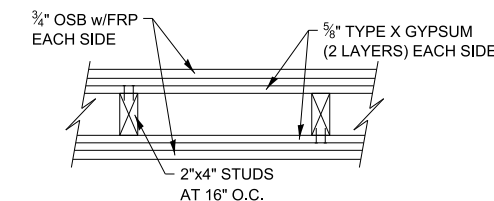

THICKNESS:	6 1/8"
APPROXIMATE WEIGHT:	12 PSF
FIRE TEST:	SWRI 01-5920-614, 12-5-94
SOUND TEST:	NGC 2363, 4-1-70

**2 HOUR INTERIOR WALL DETAIL  
GA FILE WP NO. 4136**

BASE LAYER 5/8" TYPE X GYPSUM WALLBOARD OR VENEER BASE APPLIED PARALLEL OR AT RIGHT ANGLES TO EACH SIDE OF 2 X 4 WOOD STUDS 16" O.C. WITH 1 1/4" TYPE W DRYWALL SCREWS 12" O.C. FACE LAYER 5/8" TYPE X GYPSUM WALLBOARD OR VENEER BASE APPLIED PARALLEL OR AT RIGHT ANGLES TO EACH SIDE WITH 1 1/8" TYPE W DRYWALL SCREWS 12" O.C. AND OFFSET 6" FROM SCREWS IN BASE LAYER. JOINTS STAGGERED 16" EACH LAYER AND SIDE. (LOAD-BEARING)

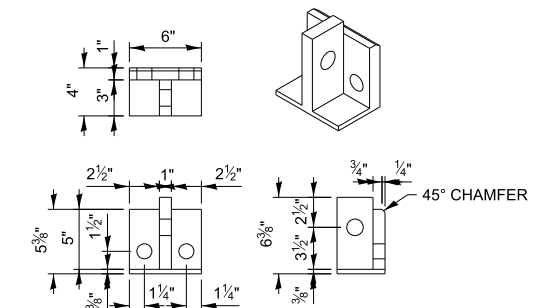

**MOUNTING BRACKET**

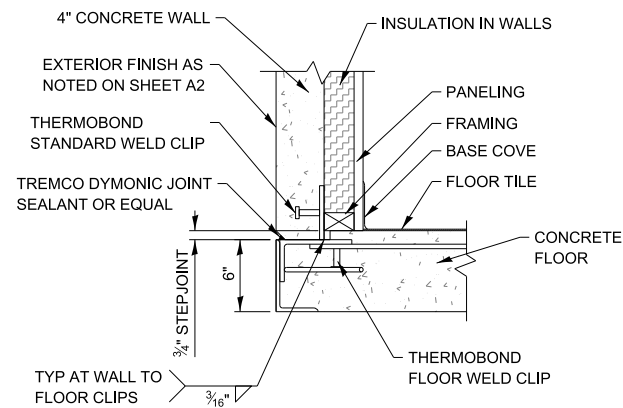

**WALL TO FLOOR SECTION**

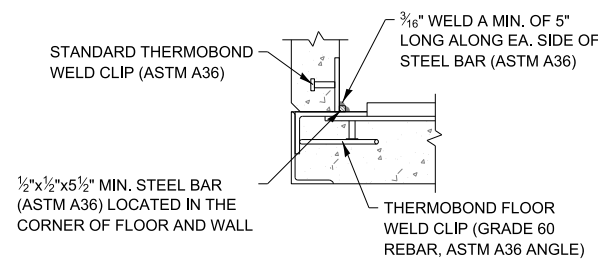

**WALL TO FLOOR WELD**

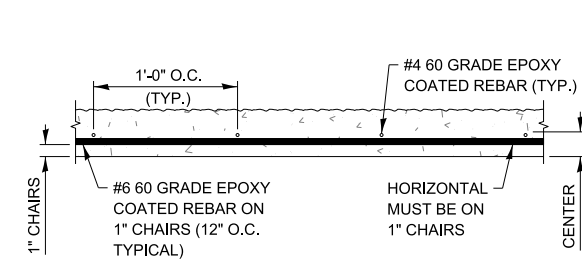

**TYPICAL FLOOR REBAR LAYOUT**

**CONSTRUCTION MATERIALS:**

**INTERIOR FINISH:**

FLOOR: 1/8" X 12" X 12" VINYL TILE WITH 4" BASE COVE  
 WALLS: 3/4" PANELING (1 1/16" OSB W/.030 FRP COATING) (CLASS "C" MINIMUM)  
 CEILING: 3/4" PANELING (1 1/16" OSB W/.030 FRP COATING) (CLASS "C" MINIMUM)

**INSULATION:**

WALLS: 3" THERMAX FOAM INSULATION (R-19) ESR-1659  
 CEILING: 5" THERMAX FOAM INSULATION (R-32) ESR-1659

**FRAMING:**

WALLS: 2" X 6" FURRING STRIPS ON END AT 24" O.C.  
 CEILING: 2" X 6" FURRING STRIPS ON END AT 24" O.C.

**CONCRETE:**

FLOOR: 5000 PSI SAND LIGHTWEIGHT  
 WALLS: 5000 PSI SAND LIGHTWEIGHT  
 CEILING: 5000 PSI SAND LIGHTWEIGHT

**CONSTRUCTION NOTES:**

- FLOORS ARE TO BE WAXED AND SEALED BEFORE SHIPPING.



**EXTERIOR ELEVATIONS - MAIN PLAZA**

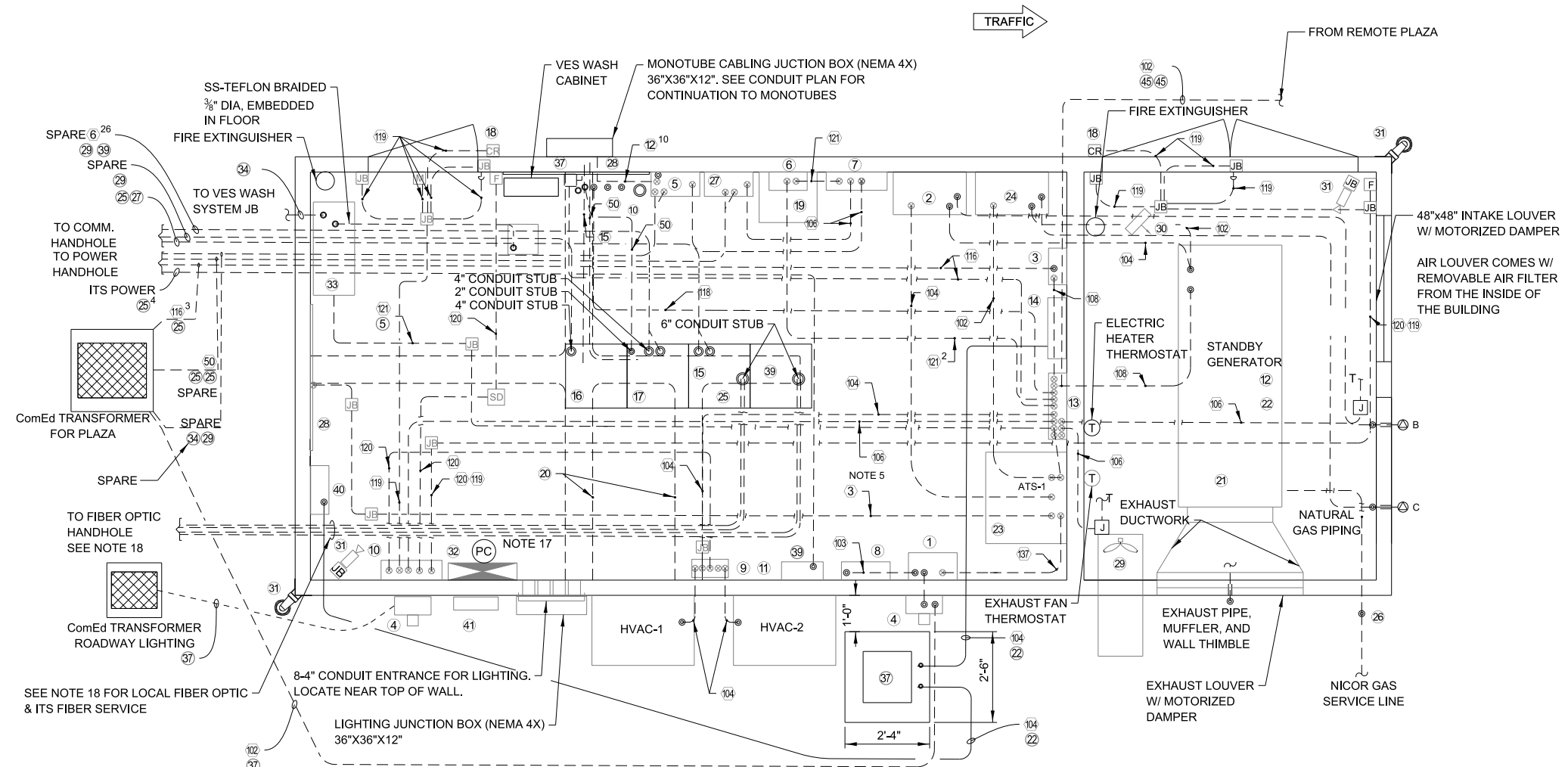

- LEGEND:**
- |  |  |
|--|--|
| ① MAIN SERVICE DISCONNECT 200A/3P                      | ②① JACKET WATER HEATER   |
| ② MTS-2 FOR GENERATOR CONTROL                          | ②② BATTERY CHARGER   |
| ③ LIGHTING CONTACTOR, TRANSFORMER, AND CIRCUIT BREAKER | ②③ ATS   |
| ④ ELECTRIC UTILITY METER                               | ②④ MTS-1 FOR GENERATOR POWER                                       |
| ⑤ VIDEO JB POWER #1                                    | ②⑤ SMF DISTRIBUTION PANEL  |
| ⑥ BYPASS SWITCH  | ②⑥ NICOR GAS SERVICE LINE  |
| ⑦ UPS-1 PANEL  | ②⑦ VIDEO JB POWER #2   |
| ⑧ LIGHTNING ARRESTER                                   | ②⑧ TSIC BOARD  |
| ⑨ TEMPERATURE ALARM                                    | ②⑨ SIDEWALL EXHAUST FAN W/ MOTORIZED DAMPER                        |
| ⑩ CARD READER PANEL                                    | ③⑩ ELECTRIC CEILING MOUNTED HEATER                                 |
| ⑪ HVAC CONTROL PANEL                                   | ③① SECURITY CAMERA   |
| ⑫ GENERATOR CONTROL PANEL                              | ③② ROADWAY LIGHTING CONTROLLER (BY ROADWAY LIGHTING DESIGNER)      |
| ⑬ MAIN DISTRIBUTION PANEL MDP-1                        | ③③ VES WASH SYSTEM CABINET LOCATION 1                              |
| ⑭ ITS 1-1 PANEL  | ③④ N/A   |
| ⑮ 19" RACK LOCAL BACKBONE FIBER                        | ③⑤ N/A   |
| ⑯ 19" RACK I-PASS READER                               | ③⑥ N/A   |
| ⑰ 19" RACK LANE CONTROLLER RACK                        | ③⑦ 5 KVA, 208V/480V OUTDOOR TYPE SINGLE PHASE TRANSFORMER, NEMA 4X |
| ⑱ FREE STANDING UPS (4KVA)                             | ③⑧ 19" RACK ITS FIBER  |
| ⑳ CABLE TRAY   | ③⑨ ITS 1-2 PANEL   |
|  | ④⑩ ROADWAY LIGHTING DISCONNECT SWITCH                              |

**CONTROL BUILDING MAIN TOLL PLAZA EQUIPMENT LAYOUT**

- NOTES:**
- SEE CABLE/CONDUIT SCHEDULES SHEET FOR CABLE TAGS.
  - SEE SYSTEM POWER SINGLE LINE DIAGRAM SHEET FOR DETAILS.
  - SEE WALL ELEVATION SHEET FOR DETAILS.
  - DOOR ALARM SWITCH, SEE DETAIL ON CONTROL BUILDING MISCELLANEOUS DETAILS SHEET.
  - PROVIDE A 3 PAIR #22 SHIELDED CABLE FOR ATS ALARMS AND ROUTE TO TSIC BOARD. ALL CONTACT CLOSURES SHALL BE ROUTED TO TSIC.
  - THE LIGHTNING PROTECTION SYSTEM DEVICE SHALL BE CONNECTED TO THE LOAD SIDE OF THE UTILITY METER.
  - FOR ROADWAY LIGHTING. ROUTE TO 30A. CIRCUIT BREAKER.
  - ALL EXCESS (SLACK) POWER AND DATA CABLES MUST BE COILED IN THE HANDHOLE. NO EXCESS CABLES WILL BE COILED INSIDE THE CABINET.
  - NOT USED.
  - PVC SCH-80 CONDUIT INSIDE BUILDING SHALL BE USED WHEN THE CONDUIT IS EITHER COVERED OR ENCASED IN CONCRETE. TRANSITION SHALL BE ALLOWED. ANY EXPOSED CONDUIT SHALL BE PVC COATED RGS. SLEEVES SHALL BE USED WHEN DEEMED NECESSARY.
  - THE CABLE LENGTH FROM THE ANTENNA TO THE I-PASS READER SHALL NOT EXCEED 150 FEET FOR MAIN PLAZA.
  - PROVIDE A 3 PAIR #22 SHIELDED CABLE FOR SMOKE DETECTOR ALARM CONTACT AND ROUTE TO CARD READER EQUIPMENT.
  - PROVIDE AN ETHERNET CABLE FROM UPS AND FROM CARD READER PANEL TO LOCAL BACKBONE RACK. NETWORK SWITCHES TO BE PROCURED BY OTHERS.

- NOTES (CONT'D):**
- TERMINATE ALARM CABLES ON TERMINAL BLOCK ON TSIC BOARD.
  - CONTRACTOR SHALL COORDINATE ALL WORK FOR UTILITY SERVICES WITH COMED AND NICOR.
  - POWER FRONT AND REAR VES CAMERAS FROM 24V DC VIDEO JUNCTION BOX #1 AND DATA LOGGER CAMERA FROM SECURITY VIDEO JUNCTION BOX #2. ALL POWER TO BE SURGE PROTECTED.
  - MOUNT PHOTOCELL 6" ABOVE TOP OF BUILDING POINTING TOWARDS NORTHEAST.
  - PROVIDE (2) 6" SDR 11 HDPE SLEEVES EACH. SLEEVE SHALL HAVE;
    - (1) 1½" CNC DUCT (SOLID GREEN)
    - (1) 1½" CNC DUCT (GREEN / WHITE STRIPE)
    - (1) 1½" CNC DUCT (BLACK / RED STRIPE)
  - LOCATION OF (4) RACKS BE IN THE MIDDLE OF THE ROOM.
  - FOR SECURITY CAMERA, CONTRACTOR TO VERIFY CLEAR UNOBSTRUCTED LINE OF SIGHT TO THE ENTRANCE DOORS.
  - INSTALL TRANSFORMER ON 6" CONCRETE PAD 1 FT AWAY FROM EXTERIOR WALL. ALL FEED TO THIS TRANSFORMER SHALL BE UNDERGROUND.

**NOTE TO DESIGNER**

THIS BASE SHEET SHOWS TYPICAL CONSTRUCTION BUT IT IS NOT A STANDARD DRAWING. IT REQUIRES COMPLETION BY THE DESIGNER PRIOR TO INSERTION INTO A CONTRACT. MICROSTATION FILES AND THE "CADD STANDARDS MANUAL" ARE AVAILABLE ON THE ILLINOIS TOLLWAY WEBSITE. THE DESIGNER SHALL ACCEPT THE RESPONSIBILITY OF THE DESIGN OF THIS SHEET UPON ITS COMPLETION AND INSERTION INTO A CONTRACT. ALL "NOTE TO DESIGNER" BOXES SHALL BE REMOVED BY THE DESIGNER PRIOR TO INSERTION OF THE SHEET INTO THE PLAN SET.

**NOTE TO DESIGNER**

IF DISTANCE BETWEEN MAIN AND REMOTE PLAZA ANTENNAS IS LESS THAN 500 FT., PROVIDE CONDUIT AND SYNC CABLE TO CONNECT ANTENNA READERS IN THE MAIN AND REMOTE CONTROL BUILDINGS.

**CONTROL BUILDING EQUIPMENT LAYOUT - MAIN PLAZA**

VERSION: 2026-03	BASE SHEET: M-BUS-2510	SHEET: 1 OF 1
---------------------	---------------------------	------------------

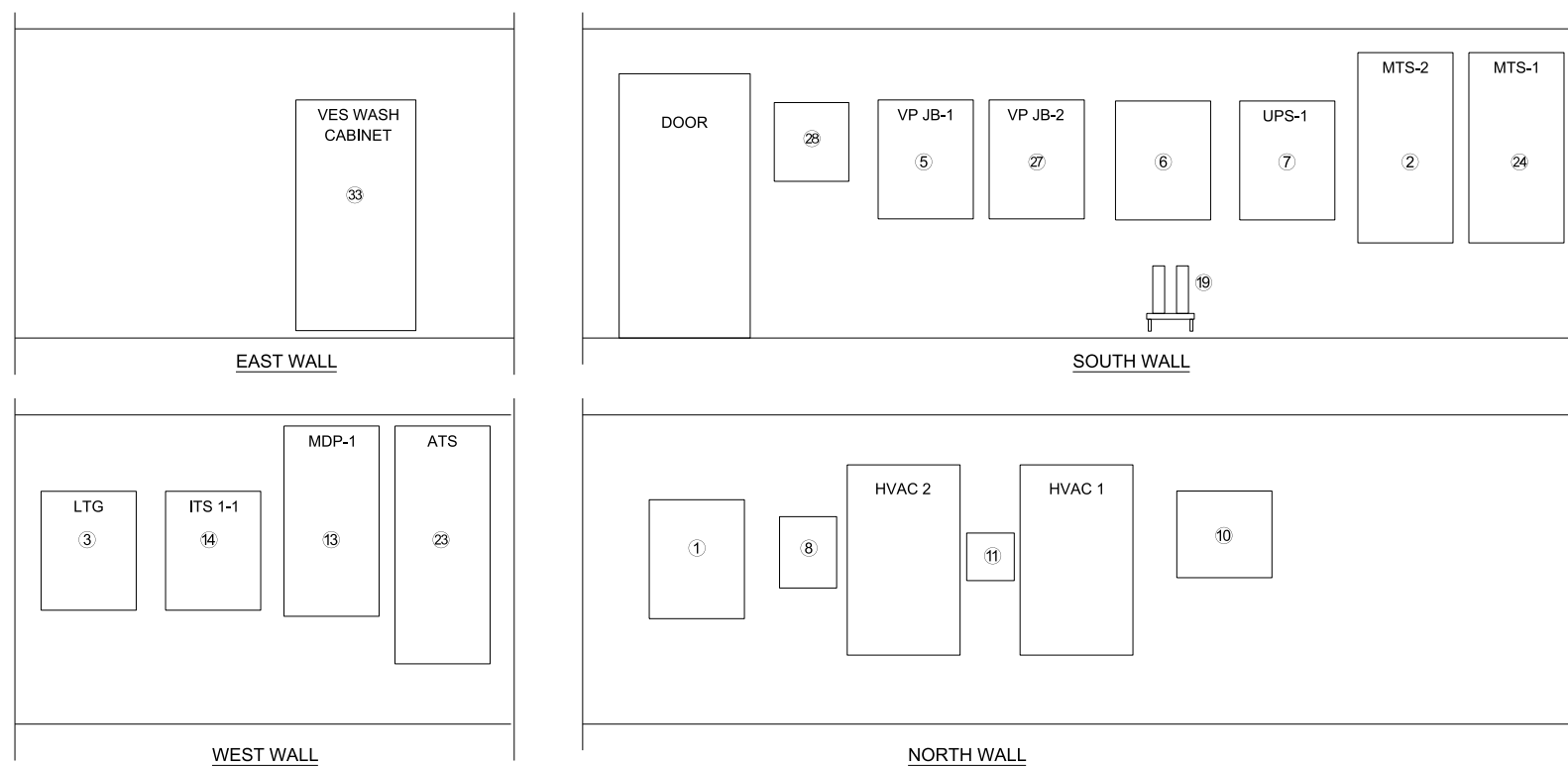

**WALL ELEVATIONS**  
NOT TO SCALE  
NOTE 2

**EQUIPMENT LEGEND**

**ITEM DESCRIPTION**

- ① MAIN SERVICE DISCONNECT 200A/3P
- ② MTS-2 FOR GENERATOR CONTROL
- ③ LIGHTING CONTACTOR 120V, 30A, 1 PHASE, 4-POLE IN A NEMA 1 ENCLOSURE WITH A THREE POSITION SELECTOR SWITCH HAND-OFF-AUTO MOUNTED ON THE COVER. TRANSFORMER DRY TYPE, 2KVA, 120V PRIMARY, 480V SECONDARY, 1-PHASE, 3-WIRE ROADWAY LIGHTING
- ⑤ VIDEO JB POWER #1
- ⑥ BYPASS MODULE
- ⑦ UPS-1 PANEL
- ⑧ LIGHTNING ARRESTOR SYSTEM
- ⑩ ITS 1-2 PANEL
- ⑪ HVAC CONTROL PANEL
- ⑬ MAIN DISTRIBUTION PANEL (MDP-1), 208Y/120V, 3 PHASE, 4W 250 AMP, MAIN CIRCUIT BREAKER
- ⑭ ITS-1 PANEL
- ⑰ FREE STANDING 4KVA UPS
- ⑳ ATS
- ㉔ MTS-1 FOR GENERATOR POWER
- ㉗ VIDEO JB POWER #2
- ㉘ CARD READER PANEL
- ㉛ VES WASH ENCLOSURE

**NOTE TO DESIGNER**

THIS BASE SHEET SHOWS TYPICAL CONSTRUCTION BUT IT IS NOT A STANDARD DRAWING. IT REQUIRES COMPLETION BY THE DESIGNER PRIOR TO INSERTION INTO A CONTRACT. MICROSTATION FILES AND THE "CADD STANDARDS MANUAL" ARE AVAILABLE ON THE ILLINOIS TOLLWAY WEBSITE. THE DESIGNER SHALL ACCEPT THE RESPONSIBILITY OF THE DESIGN OF THIS SHEET UPON ITS COMPLETION AND INSERTION INTO A CONTRACT. ALL "NOTE TO DESIGNER" BOXES SHALL BE REMOVED BY THE DESIGNER PRIOR TO INSERTION OF THE SHEET INTO THE PLAN SET.

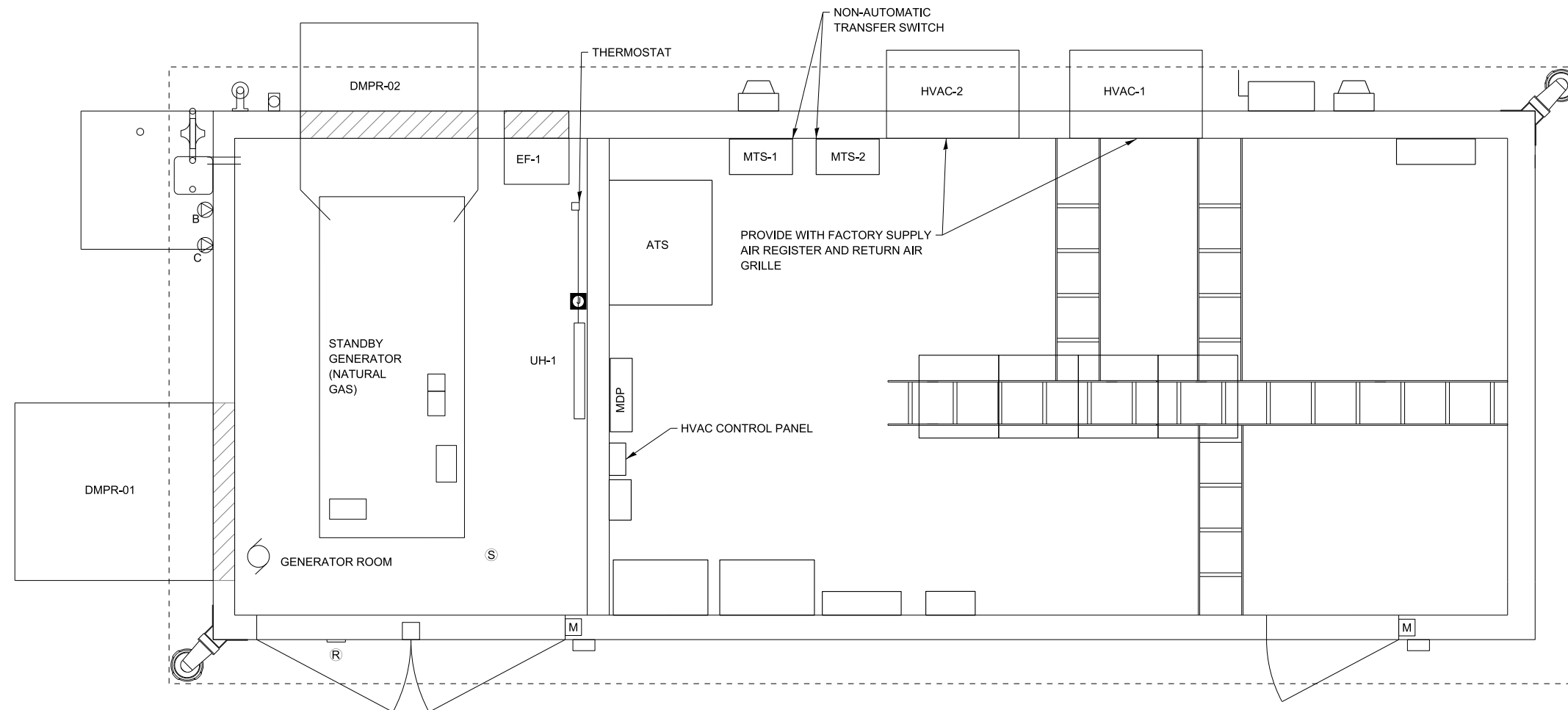

**BUILDING MECHANICAL PLAN**  
NOT TO SCALE

**NOTES:**

1. UNIT SHALL HAVE ARI CERTIFIED COILS, AIWCA RATED FANS, AND UL LISTED & LABELED ELECTRICAL COMPONENTS.
2. PROVIDE HVAC UNITS WITH FACTORY SUPPLY AND RETURN GRILLES.
3. HVAC PROVIDE LEAD/LAG THERMOSTAT CONTROLLER BARD MODEL #MC4001-AC WITH BASE ALARMS AND ETHERNET ACCESS.
4. ALL MANUFACTURERS AND PART NUMBERS ARE FOR REFERENCE. THE CONTRACTOR SHALL PROVIDE CALCULATIONS FOR HVAC AND HEATING SYSTEM BASED ON BUILDING CONSTRUCTION AND INTERNAL BUILDING LOADS.

ELECTRICAL ROOM																						
MARK	LOCATION	SERVES	NOM. TON	TOTAL AIRFLOW CFM	OUTSIDE AIRFLOW CFM	ESP (IN WG)	REFRIG. TYPE	COOLING DATA						HEATING DATA				ELECTRICAL DATA			MANUFACTURER/ MODEL NUMBER	REMARKS
								TOTAL CAP MBH	SENS CAP MBH	EAT (DEG F) DB	EAT (DEG F) WB	OUTDOOR TEMP (DEG F)	MIN. EER AT ARI CONDITIONS	CAP MBH	EAT (DEG F) DB	OUTDOOR TEMP (DEG F)	SUPPLEMENTAL HEATING (KW)	VOLTS	PH	HZ		
HVAC-01	OUTSIDE	BUILDING	4	1500	-	0.15	R454B A2L	45.5	34.0	75	62	90	11	17.1	70	0	5	240	1	60	BARD W5SAF0A05ZPXXXJ	
HVAC-02	OUTSIDE	BUILDING	4	1500	-	0.15	R454B A2L	45.5	34.0	75	62	90	11	17.1	70	0	5	240	1	60	BARD W5SAF0A05ZPXXXJ	

EXHAUST FAN AND DAMPERS											
MARK	LOCATION	MAKE	MODEL	TYPE	CFM	ESP IN WG	FAN RPM	DRIVE TYPE	MOTOR DATA		NOTES
									HP	V / PH / HZ	
EF-1	GENERATOR ROOM	GREENHECK	SE1	EXHAUST FAN	750	0.25	1307	DIRECT	1/8	115/ 1/ 60	WITH MOTORIZED LOUVERS AND GALV. HOUSING, THERMOSTAT CONTROLLED

EXHAUST FAN AND DAMPERS									
MARK	LOCATION	DESCRIPTION	TYPE	MAKE	MODEL	SIZE	ELECTRICAL		NOTES
							V / PH / HZ		
DMPR-01	GENERATOR ROOM	SUPPLY DAMPER	MOTORIZED DAMPER	GREENHECK	VCD-23	48" x 48"	115/ 1/ 60		LOUVERS FAIL OPEN ON LOSS OF POWER, INSTALL HOOD WITH SS MESH FILTER ON EXTERIOR
DMPR-02	GENERATOR ROOM	EXHAUST DAMPER	MOTORIZED DAMPER	GREENHECK	135 TLCD	48" x 48"	460 / 3 / 60		LOUVERS FAIL OPEN ON LOSS OF POWER, INSTALL PARTIAL HOOD WITH STAINLESS STEEL WIRE GRID

ELECTRIC UNIT HEATER SCHEDULE (UH)								
MARK	ROOM	MAKE	MODEL	TYPE	CAPACITY (kW)	CFM	V / PH / HZ	NOTES
UH-1	GENERATOR	INDEECO	ULI	WALL MOUNTED	2KW/1.5KW	300	240/ 1 / 60	INCLUDE DISCONNECT

**NOTE TO DESIGNER**

THIS BASE SHEET SHOWS TYPICAL CONSTRUCTION BUT IT IS NOT A STANDARD DRAWING. IT REQUIRES COMPLETION BY THE DESIGNER PRIOR TO INSERTION INTO A CONTRACT. MICROSTATION FILES AND THE "CADD STANDARDS MANUAL" ARE AVAILABLE ON THE ILLINOIS TOLLWAY WEBSITE. THE DESIGNER SHALL ACCEPT THE RESPONSIBILITY OF THE DESIGN OF THIS SHEET UPON ITS COMPLETION AND INSERTION INTO A CONTRACT. ALL "NOTE TO DESIGNER" BOXES SHALL BE REMOVED BY THE DESIGNER PRIOR TO INSERTION OF THE SHEET INTO THE PLAN SET.

**NOTE TO DESIGNER**

THE ESTIMATED EQUIPMENT BUILDING LOADS FOR EQUIPMENT IS 19,000 BTU/HR. THE DESIGNER SHALL SIZE THE HVAC SYSTEMS ACCORDINGLY.



**MECHANICAL PLAN - MAIN PLAZA**

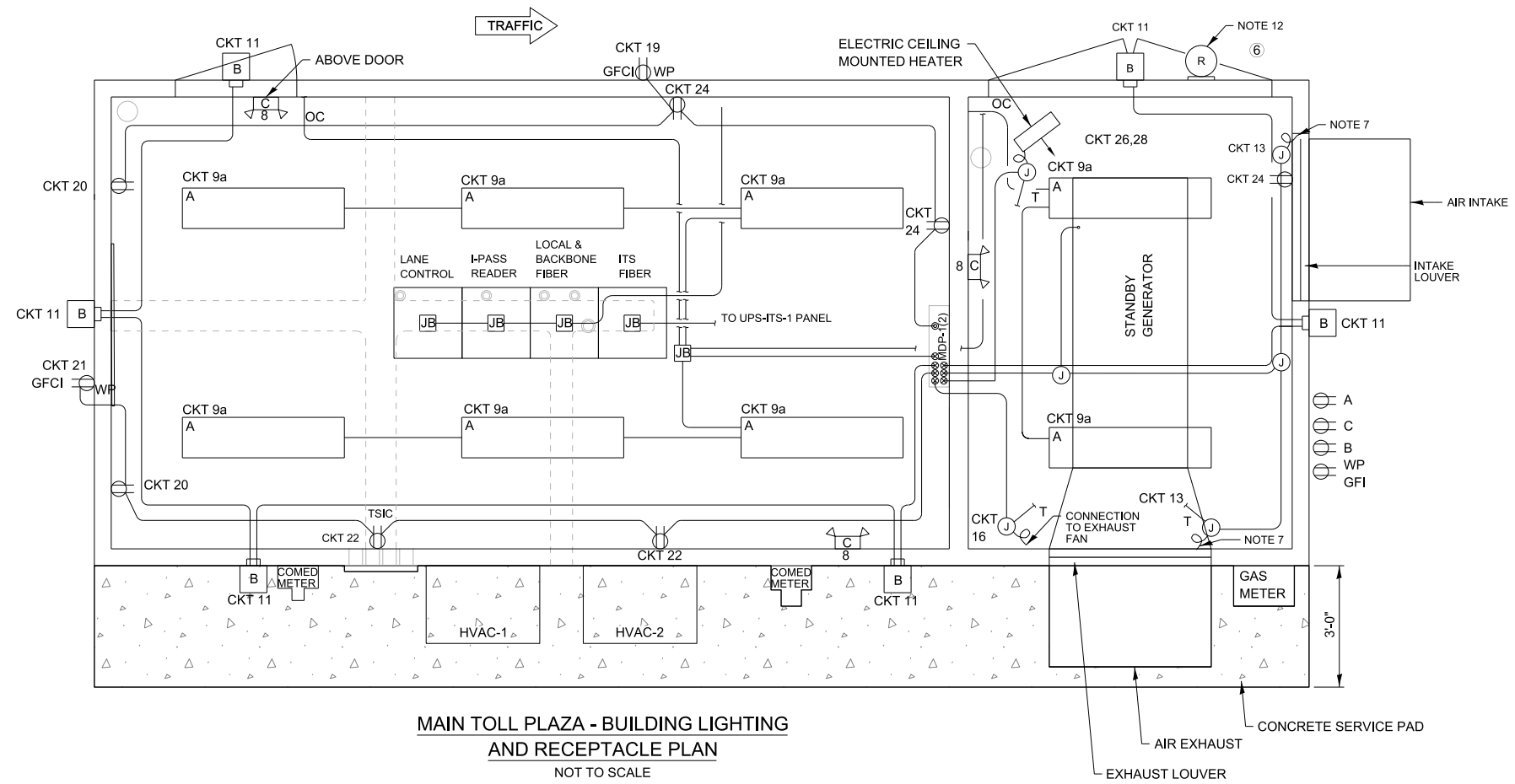

**MAIN TOLL PLAZA - BUILDING LIGHTING AND RECEPTACLE PLAN**  
NOT TO SCALE

**NOTES:**

1. SEE CABLE/CONDUIT SCHEDULES SHEET FOR CABLE TAGS.
2. RECEPTACLE AND LIGHTING CONDUIT SHALL BE 3/4" WITH 2-1/C #12 AND 1/C #12 GRD, UNLESS OTHERWISE NOTED.
3. FOR PANEL SCHEDULES, SEE PANELBOARD SCHEDULES SHEET.
4. PROVIDE CONNECTION TO RECEPTACLES FOR THE EQUIPMENT RACKS AS SPECIFIED. THE PLUG STRIP SHALL BE MOUNTED TO THE SIDE OF THE CABINET AS DIRECTED BY THE ENGINEER.
5. FOR LIGHTING FIXTURE SCHEDULE, ELECTRICAL SYMBOLS, LEGEND, AND ABBREVIATIONS, SEE LEGEND SHEET.
6. LIGHTING AND RECEPTACLES SHALL BE FED FROM PANEL MDP-1.
7. PROVIDE CONNECTIONS TO THE MOTORIZED DAMPER AND GEN. CONTROL PANEL DAMPERS TO BE CONTROLLED FROM GEN. CONTROLLER.
8. CONNECT EMERGENCY BATTERY PACKS AHEAD OF LIGHTING CIRCUIT.
9. COMMUNICATION AND EQUIPMENT RACK SHALL BE AS FOLLOWS: I-PASS LANE CONTROL BACKBONE FIBER ITS FIBER
10. CONTRACTOR SHALL COORDINATE FINAL RACK LAYOUT WITH THE ENGINEER AND THE ILLINOIS TOLLWAY.
11. NETWORK SWITCHES PROCURED BY OTHERS.
12. RED INDICATOR LIGHT INSTALLED FACING THE ROADWAY AND ACTIVATED WHEN GENERATOR IS RUNNING.
13. SEE MISCELLANEOUS SCHEMATIC DIAGRAMS SHEET FOR EXTERIOR LIGHTING CONTROLS.

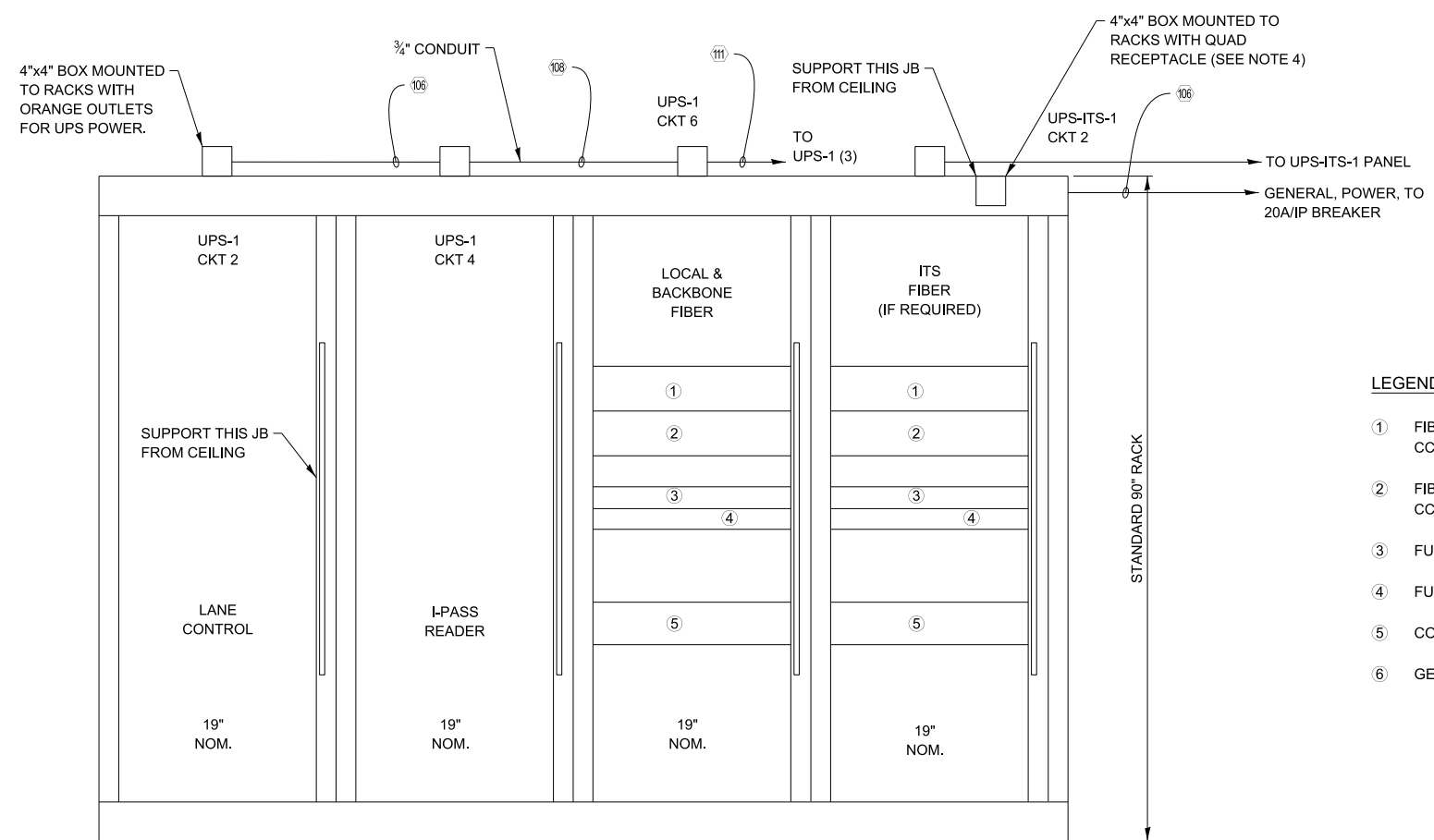

**COMMUNICATIONS AND EQUIPMENT RACK ELEVATION**  
NOT TO SCALE

**LEGEND:**

- ① FIBER-OPTIC CORNING RACK INTERCONNECT CENTER CCH-04U (4 RU)
- ② FIBER-OPTIC CORNING RACK INTERCONNECT CENTER CCH-04U (4 RU)
- ③ FUTURE NETWORK SWITCHES - (1 RU) NOTE 11
- ④ FUTURE NETWORK SWITCHES - (1 RU) NOTE 11
- ⑤ COMMSCOPE MODULAR PATCH PANEL - (2 RU)
- ⑥ GENERATOR RUNNING LIGHT

**NOTE TO DESIGNER**

THIS BASE SHEET SHOWS TYPICAL CONSTRUCTION BUT IT IS NOT A STANDARD DRAWING. IT REQUIRES COMPLETION BY THE DESIGNER PRIOR TO INSERTION INTO A CONTRACT. MICROSTATION FILES AND THE "CADD STANDARDS MANUAL" ARE AVAILABLE ON THE ILLINOIS TOLLWAY WEBSITE. THE DESIGNER SHALL ACCEPT THE RESPONSIBILITY OF THE DESIGN OF THIS SHEET UPON ITS COMPLETION AND INSERTION INTO A CONTRACT. ALL "NOTE TO DESIGNER" BOXES SHALL BE REMOVED BY THE DESIGNER PRIOR TO INSERTION OF THE SHEET INTO THE PLAN SET.



**CONTROL BUILDING LIGHTING AND RECEPTACLE PLAN - MAIN PLAZA**

VERSION: 2021-03	BASE SHEET: M-BUS-2513	SHEET: 1 OF 1
---------------------	---------------------------	------------------

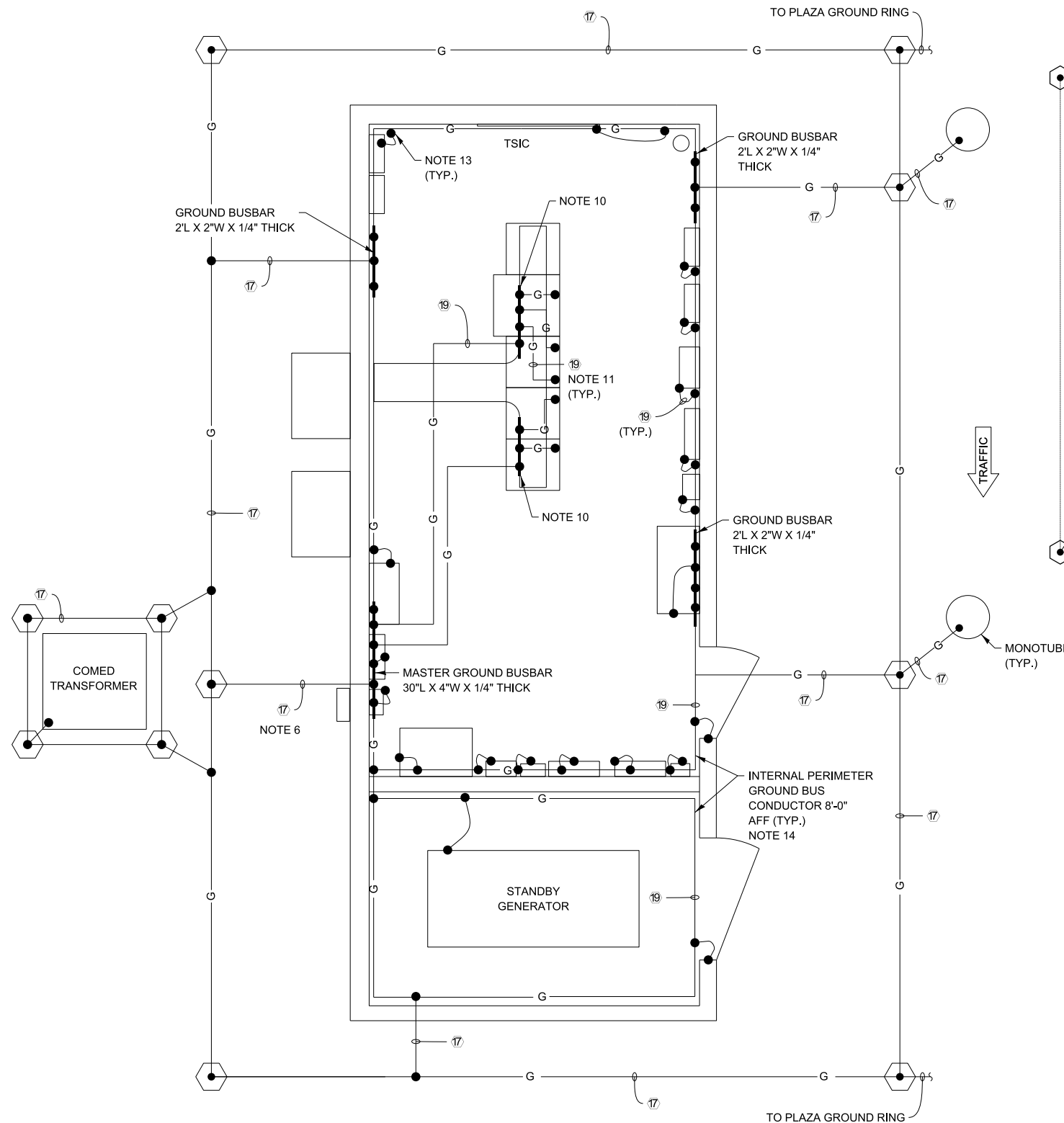

**BUILDING ELECTRICAL GROUNDING LAYOUT**  
NOT TO SCALE

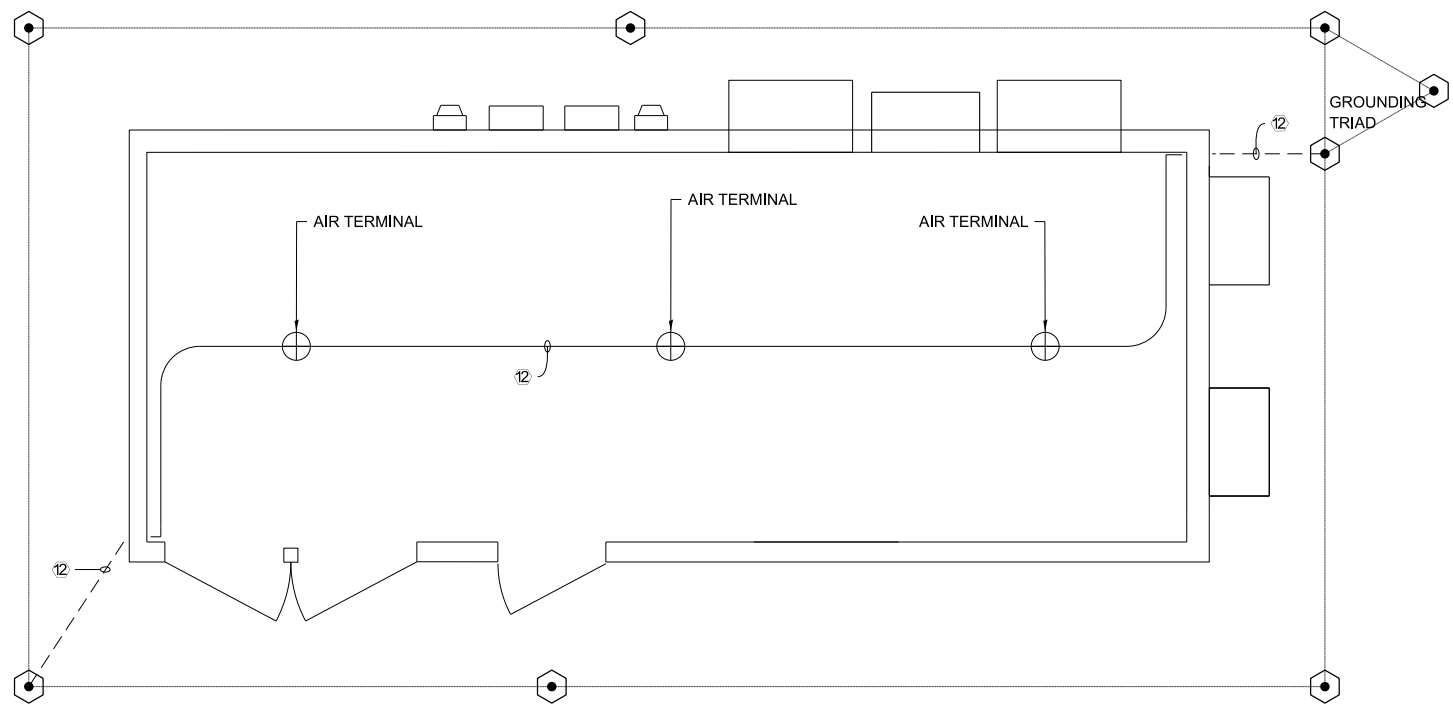

**FACILITY - GROUNDING OF LIGHTNING PROTECTION SYSTEM**  
NOT TO SCALE

**NOTES:**

1. SEE CABLE/CONDUIT SCHEDULE SHEET FOR CABLE TAGS.
2. NOT USED
3. DETAIL SHOWS INSTALLATION IN UNPAVED AREA. WHEN INSTALLING IN A PAVED AREA, INCORPORATE GROUND WELL IN THE POUR.
4. GROUND WELLS ARE REQUIRED AT EVERY GROUND ROD.
5. SEE GROUNDING SCHEMATIC SHEET FOR MORE DETAILS.
6. PROVIDE 1" SCHEDULE 40 PVC CONDUIT FOR GROUND CABLES UNDER BUILDING (TYP.).
7. ALL COPPER GROUND BARS SHALL BE OF HARD DRAWN, COMMERCIALY PURE, ELECTROLYTIC COPPER, FOR USE AS AN ELECTRICAL CONDUCTOR AND SHALL COMPLY WITH ASTM SPEC. B-187 OF LATEST DATE.
8. BOLTS, NUTS, & WASHERS USED FOR CONNECTION TO GROUND BUSBARS SHALL BE SOLID COPPER.
9. WELD PER MANUFACTURER SPECIFICATION (ERICO PRODUCTS OR BURNDY CORP.).
10. THE COPPER GROUND BUSBAR SHALL BE MOUNTED TO THE CABLE TRAY ABOVE EQUIPMENT RACKS.
11. PROVIDE A #2 AWG GROUND CABLE FROM THE FRAME OF EACH EQUIPMENT RACK TO THE GROUND BUS AS SHOWN. THE CABLE SHALL BE BOLTED TO THE RACK USING A SEAMLESS HEAVY DUTY COMPRESSION TERMINAL.
12. A FOUR INCH GAP SHALL BE PROVIDED BETWEEN THE ENDS OF THE TWO CONDUCTORS THAT MAKE UP THE INTERNAL PERIMETER GROUND BUS CONDUCTOR.
13. ALL EQUIPMENT LOCATED INSIDE THE BUILDING SHALL BE BONDED TO THE MAIN GROUND BUS OR THE INTERNAL PERIMETER GROUND CONDUCTOR WITH A #2 AWG GROUND CABLE. ALL CONNECTIONS MUST BE EXOTHERMICALLY WELDED.
14. THE INTERNAL PERIMETER GROUND BUS CONDUCTOR MUST BE INSTALLED HORIZONTALLY ALONG THE WALL APPROXIMATELY 8 FEET ABOVE FINISHED FLOOR. THE CONDUCTOR SHALL BE SUPPORTED 2 INCHES FROM THE WALL SURFACE ON INSULATED STANDOFFS. THE STANDOFFS SHALL BE INSTALLED AT INTERVALS AS NECESSARY TO KEEP THE CONDUCTOR SECURELY IN PLACE WITHOUT NOTICEABLE SAGS AND BENDS.
15. THE GROUND BUSBARS MUST BE MOUNTED APPROXIMATELY 8 FEET ABOVE FINISHED FLOOR AND MOUNTED TO WALL USING A MOUNTING BRACKET WITH INSULATOR.

**NOTE TO DESIGNER**

THIS BASE SHEET SHOWS TYPICAL CONSTRUCTION BUT IT IS NOT A STANDARD DRAWING. IT REQUIRES COMPLETION BY THE DESIGNER PRIOR TO INSERTION INTO A CONTRACT. MICROSTATION FILES AND THE "CADD STANDARDS MANUAL" ARE AVAILABLE ON THE ILLINOIS TOLLWAY WEBSITE. THE DESIGNER SHALL ACCEPT THE RESPONSIBILITY OF THE DESIGN OF THIS SHEET UPON ITS COMPLETION AND INSERTION INTO A CONTRACT. ALL "NOTE TO DESIGNER" BOXES SHALL BE REMOVED BY THE DESIGNER PRIOR TO INSERTION OF THE SHEET INTO THE PLAN SET.



**CONTROL BUILDING  
GROUNDING DETAILS - MAIN  
PLAZA**

VERSION: 2025-03	BASE SHEET: M-BUS-2514	SHEET: 1 OF 2
---------------------	---------------------------	------------------

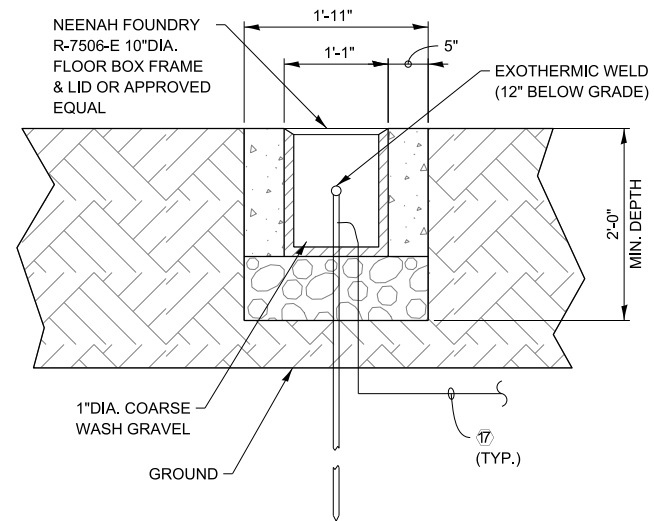

**GROUND WELL ELEVATION DETAIL**  
NOTE 3

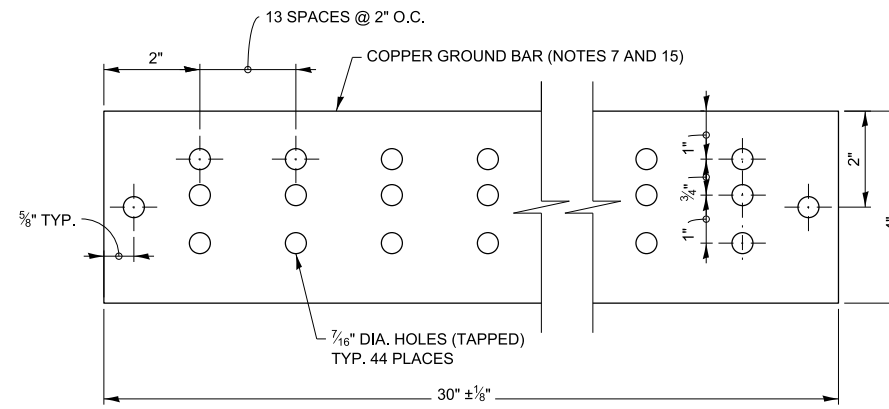

**MASTER GROUND BUSBAR  
SUPPORT SPACING DETAIL**

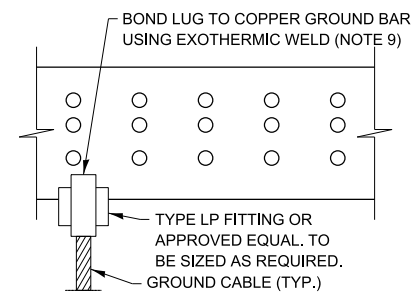

**MASTER GROUND BUSBAR  
CONNECTION DETAIL**  
(NOT TO SCALE)

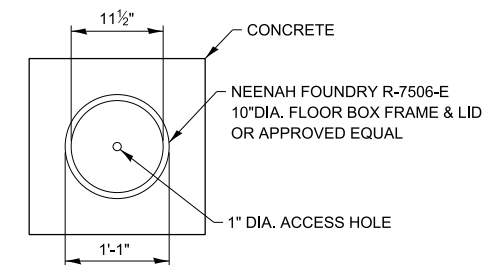

**GROUND WELL PLAN DETAIL**

**NOTE TO DESIGNER**

THIS BASE SHEET SHOWS TYPICAL CONSTRUCTION BUT IT IS NOT A STANDARD DRAWING. IT REQUIRES COMPLETION BY THE DESIGNER PRIOR TO INSERTION INTO A CONTRACT. MICROSTATION FILES AND THE "CADD STANDARDS MANUAL" ARE AVAILABLE ON THE ILLINOIS TOLLWAY WEBSITE. THE DESIGNER SHALL ACCEPT THE RESPONSIBILITY OF THE DESIGN OF THIS SHEET UPON ITS COMPLETION AND INSERTION INTO A CONTRACT. ALL "NOTE TO DESIGNER" BOXES SHALL BE REMOVED BY THE DESIGNER PRIOR TO INSERTION OF THE SHEET INTO THE PLAN SET.



**CONTROL BUILDING  
GROUNDING DETAILS - MAIN  
PLAZA**

PANELBOARD				MAINS									
MDP-1				300A. MCB									
VOLTAGE				BUS RATING									
120/208V				300A.									
PHASE/WIRE				MOUNTING									
3/4				SURFACE									
DESCRIPTION	CKT NO.	LOAD (WATTS)			AMPS/ POLES	CKT BKR	CKT BKR	AMPS/ POLES	LOAD (WATTS)			CKT NO.	DESCRIPTION
PANEL MDP-2	1	8800			100/3			30/1			2	SPARE	
	3		8060					20/1		200	4	LIGHTING CONTACTOR (CONTROL)	
	5			13400				50A/2P		3600	6	HVAC 1	
EMERGENCY LIGHT	7	200			20/1			50A/2P	3600		8	HVAC 2	
INTERIOR LIGHTS	9		400		20/1			50A/2P		3600	10	HVAC 2	
EXTERIOR BUILDING LIGHTS	11			400	20/1			60/2			12	SPARE	
MOTORIZED DAMPERS	13	180			20/1						14	SPARE	
GEN. BATTERY CHARGER	15		160		20/1			20/1		400	16	EXHAUST FAN	
GEN. JACKET WATER HTR.	17			1500	20/1			20/1			18	SPARE	
EXTERIOR RECEPTACLE	19	400			20/1			20/1	400		20	INTERIOR RECEPTACLES	
EXTERIOR RECEPTACLE	21		400		20/1			20/1		400	22	INTERIOR RECEPTACLES	
SPARE	23				20/1			20/1		400	24	INTERIOR RECEPTACLES	
SPARE	25	--			20/2			20/2	375		26	ELECTRIC CEILING MOUNTED HEATER	
	27									375	28	ELECTRIC CEILING MOUNTED HEATER	
VES WASH SYSTEM (LOC 1)	29			2500	30/1			50A/2P		1250	30	UPS-1 (TOLLING & ITS)	
SPARE	31				40/1			50A/2P	1250		32	UPS-1 (TOLLING & ITS)	
ROADWAY LTG TRANSFORMER	33		960		20/2			20/1			34	SPARE	
	35			960				20/1			34	SPARE	
SPARE	37				30/1			30/2			38	SPARE	
SPARE	39				20/1			20/1			40	SPARE	
SPARE	41				20/1			20/1			42	SPARE	
"A"		9580								5625		"A"	
"B"			9980							4975		"B"	
"C"				18760						8850		"C"	
TOTAL WATTS "A,B,C"		= 57745 KW											

PANELBOARD				MAINS				
UPS-1				30A. 2P. MCB				
VOLTAGE				BUS RATING				
120V./208V.				60A.				
PHASE/WIRE				MOUNTING				
1/3				SURFACE				
DESCRIPTION	LOAD (WATTS)	AMPS/ POLES	CKT NO.	CKT NO.	AMPS/ POLES	LOAD (WATTS)	CKT NO.	DESCRIPTION
SPARE	1	--	20/1		20/1	400	2	RACK RECEPTACLE (LCC)
SPARE	3	--	20/1		20/1	400	4	RACK RECEPTACLE (I-PASS)
SPARE	5	--	20/1		20/1	400	6	RACK RECEPTACLE (FIBER)
SPARE	7	--	20/1		20/1	200	8	CARD READER PANEL
VIDEO POWER JUNCTION BOX 1	9	500	20/1		20/1	--	10	SPARE
VIDEO POWER JUNCTION BOX 2	11	400	20/1		20/1	65	12	VIDEO POWER JUNCTION BOX (DATA LOGGER)
SUBTOTAL "A"		900				1465		
TOTAL WATTS "A,B"		= 2.4 KW						

PANELBOARD				MAINS				
ITS 1				30A. 2P. MCB				
VOLTAGE				BUS RATING				
120V / 208V				60A.				
PHASE/WIRE				MOUNTING				
1/3				SURFACE				
DESCRIPTION	LOAD (WATTS)	AMPS/ POLES	CKT NO.	CKT NO.	AMPS/ POLES	LOAD (WATTS)	CKT NO.	DESCRIPTION
SPARE	1	--	30/2P		10/1P	200	2	SPARE
	3	--			10/1P	--	4	SPARE
SPARE	5	--	10/1P		10/1P		6	SPARE
SPARE	7	--	10/1P		10/1P		8	SPARE
SUBTOTAL = --		--				200		
TOTAL WATTS "A,B"		= 0.2 KW						

NOTE TO DESIGNER

THIS BASE SHEET SHOWS TYPICAL CONSTRUCTION BUT IT IS NOT A STANDARD DRAWING. IT REQUIRES COMPLETION BY THE DESIGNER PRIOR TO INSERTION INTO A CONTRACT. MICROSTATION FILES AND THE "CADD STANDARDS MANUAL" ARE AVAILABLE ON THE ILLINOIS TOLLWAY WEBSITE. THE DESIGNER SHALL ACCEPT THE RESPONSIBILITY OF THE DESIGN OF THIS SHEET UPON ITS COMPLETION AND INSERTION INTO A CONTRACT. ALL "NOTE TO DESIGNER" BOXES SHALL BE REMOVED BY THE DESIGNER PRIOR TO INSERTION OF THE SHEET INTO THE PLAN SET.



**Illinois  
Tollway**

**PANELBOARD SCHEDULES  
- MAIN PLAZA**

VERSION: 2026-03	BASE SHEET: M-BUS-2515	SHEET: 1 OF 1
---------------------	---------------------------	------------------

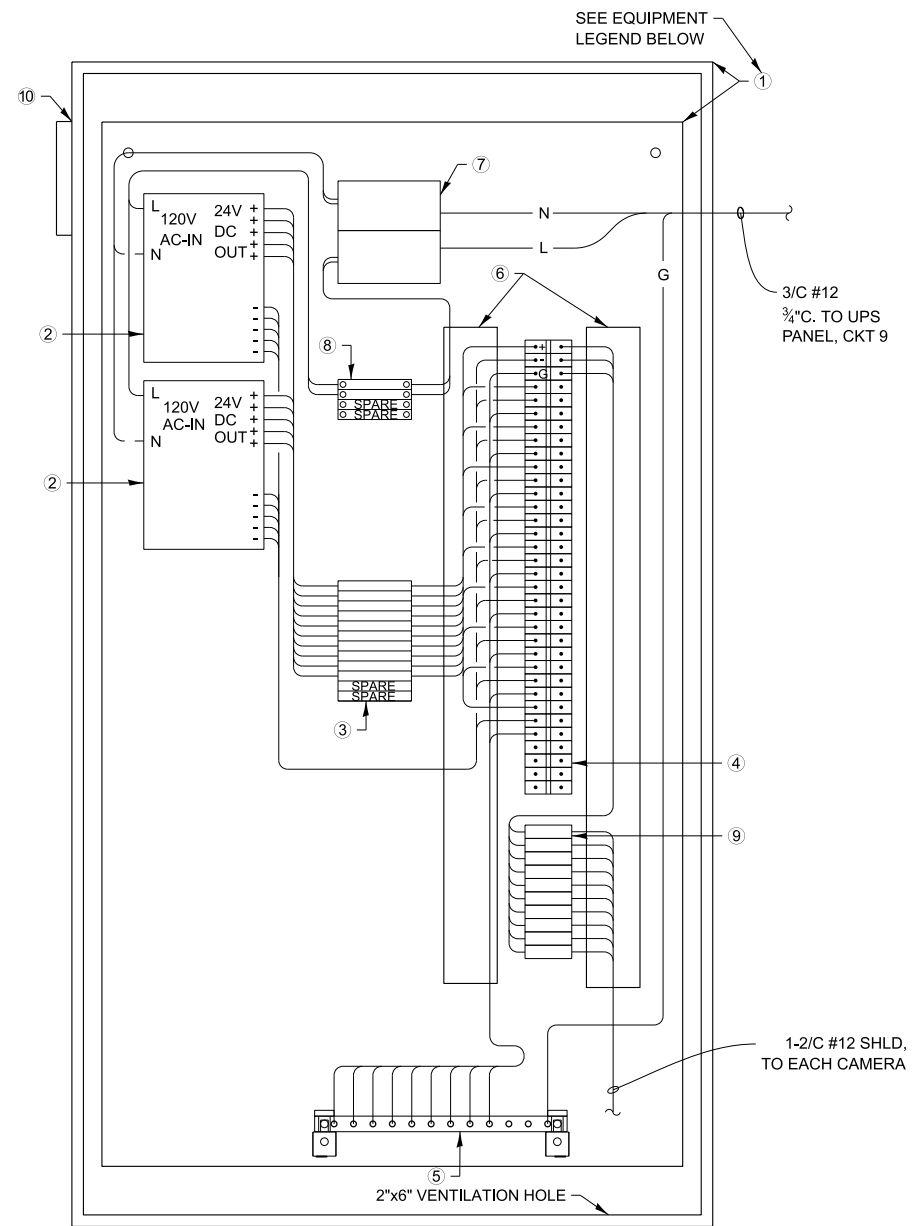

**FRONT & REAR VES CAMERA VIDEO POWER JUNCTION BOX - MAIN PLAZA ALTERNATIVE LAYOUT**  
NOT TO SCALE

**EQUIPMENT LEGEND - VIDEO POWER JUNCTION BOX (ALTERNATIVE LAYOUT)**

ITEM	QUANTITY (SAMPLE)	DESCRIPTION
①	1	48"H X 24"W X 8"D NEMA 1 ENCLOSURE WITH 44"H X 22 1/2"W BACK PANEL, HOFFMAN CATALOG NO. A-482408LE, WITH WHITE PANEL.
②	2	POWER SUPPLY, 24VDC, TDK-LAMBDA NO. QM7FSDL 24/24DMS 24/24DMS 24/24DMS 24/24DMS 24/24DMS.
③	12	TERMINAL BLOCKS, FUSE SWITCH TYPE WITH BLOWN FUSE INDICATOR COMPLETE WITH 5 AMP FUSE, MOUNTING RAIL, ANCHORS, BARRIERS, MARKING STRIPS AND JUMPERS, ALLEN BRADLEY CATALOG NO. 1492-FB1M30-D1.
④	21	TERMINAL BLOCKS, ON POLE PANEL MOUNT BLOCK SCREW TERMINAL WITH WIRE CLAMP, ALLEN BRADLEY CATALOG NO. 1492-CD6.
⑤	1	GROUND BAR SYSTEM WITH INSULATED MOUNTING BRACKET, HOFFMAN CATALOG NO. PGS2K.
⑥	LOT	PANDUIT PLASTIC WIRING DUCT SNAP-IN SLOT DESIGN AND NON-SLIP COVER, 1"W X 1"H, CATALOG NO. F1X1LG6 WITH COVER C1LG6.
⑦	1	POWER DISTRIBUTION BLOCK MARATHON NO. 1322580.
⑧	4	SQUARE D, QOU 115 1P/15A BREAKER.
⑨	10	SURGE SUPPRESSOR MTL MODEL ZB24580.
⑩	1	SQUARE AXIAL FAN 4 1/16" x 4 1/16", 1 1/2" IN DEPTH, 115 CFM, IP20, CAST ALUMINUM FRAME, 115V AC, AND COMPACT AXIAL FAN GUARD 4 1/16" x 4 1/16"

**EQUIPMENT LEGEND - VIDEO POWER JUNCTION BOX**

ITEM	QUANTITY	DESCRIPTION
①	1	48"H X 24"W X 8"D NEMA 1 ENCLOSURE WITH 44"H X 22 1/2"W BACK PANEL, HOFFMAN CATALOG NO. A-482408LE, WITH WHITE PANEL.
②	4	POWER SUPPLY 24VDC, MEANWELL MODEL NO. SDR-240-24
③	24	TERMINAL BLOCKS, FUSE SWITCH TYPE WITH BLOWN FUSE INDICATOR COMPLETE WITH 5 AMP FUSE, MOUNTING RAIL, ANCHORS, BARRIERS, MARKING STRIPS AND JUMPERS, ALLEN BRADLEY CATALOG NO. 1492-FB1M30-D1.
④	42	TERMINAL BLOCKS, ON POLE PANEL MOUNT BLOCK SCREW TERMINAL WITH WIRE CLAMP, ALLEN BRADLEY CATALOG NO. 1492-CD6.
⑤	1	GROUND BAR SYSTEM WITH INSULATED MOUNTING BRACKET, HOFFMAN CATALOG NO. PGS2K.
⑥	LOT	PANDUIT PLASTIC WIRING DUCT SNAP-IN SLOT DESIGN AND NON-SLIP COVER, 1"W X 1"H, CATALOG NO. F1X1LG6 WITH COVER C1LG6.
⑦	1	POWER DISTRIBUTION BLOCK MARATHON NO. 1322580.
⑧	4	SQUARE D, QOU 115 1P/15A BREAKER.
⑨	20	SURGE SUPPRESSOR MTL MODEL ZB24580.
⑩	1	SQUARE AXIAL FAN 4 1/16" x 4 1/16", 1 1/2" IN DEPTH, 115 CFM, IP20, CAST ALUMINUM FRAME, 115V AC, AND COMPACT AXIAL FAN GUARD 4 1/16" x 4 1/16"

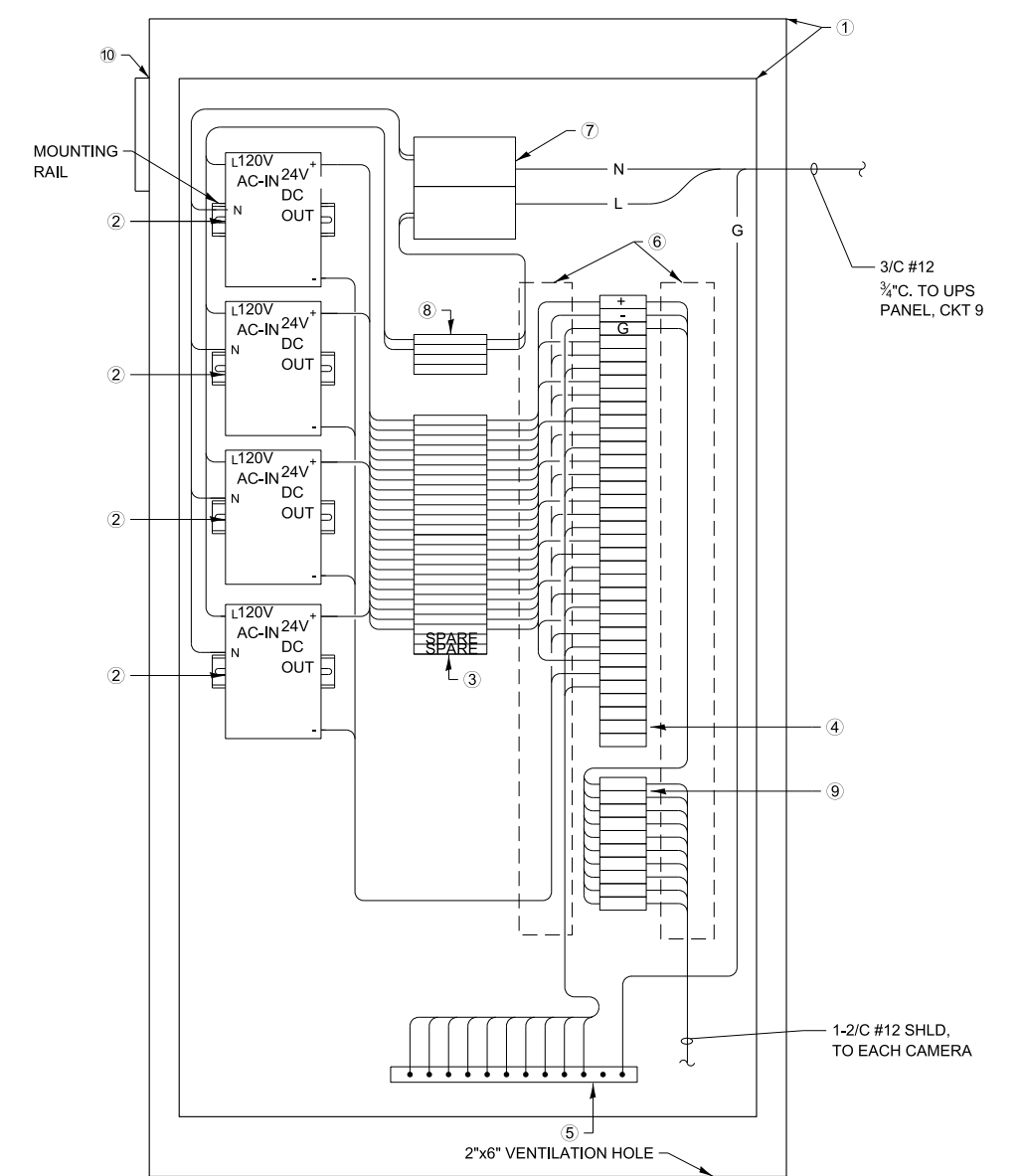

**FRONT & REAR VES CAMERA VIDEO POWER JUNCTION BOX**  
N.T.S.  
VIDEO POWER JUNCTION BOX REMOTE PLAZA

**NOTES TO DESIGNER**

- THIS BASE SHEET SHOWS TYPICAL NEW CONSTRUCTION BUT IT IS NOT A STANDARD DRAWING. IT REQUIRES COMPLETION BY THE DESIGNER PRIOR TO INSERTION INTO A CONTRACT. MICROSTATION FILES AND THE "CADD STANDARDS MANUAL" ARE AVAILABLE ON THE ILLINOIS TOLLWAY WEBSITE. THE DESIGNER SHALL ACCEPT THE RESPONSIBILITY OF THE DESIGN OF THIS SHEET UPON ITS COMPLETION AND INSERTION INTO A CONTRACT. ALL "NOTE TO DESIGNER" BOXES SHALL BE REMOVED BY THE DESIGNER PRIOR TO INSERTION OF THE SHEET INTO THE PLAN SET.
- THE DESIGNER SHALL ADJUST DETAIL AND QUANTITIES AS REQUIRED FOR NUMBER OF VES CAMERAS.
- THE DESIGNER SHALL INCLUDE VIDEO POWER JUNCTION BOX DETAILS (MHTS-2100 SERIES BASE SHEETS) FOR SECURITY CAMERAS AND DATA LOGGER CAMERA.

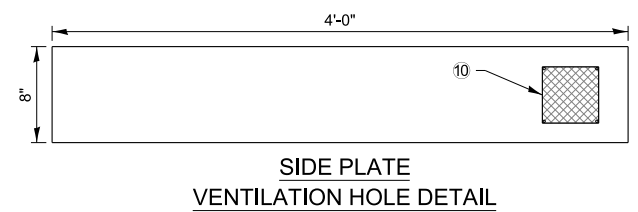
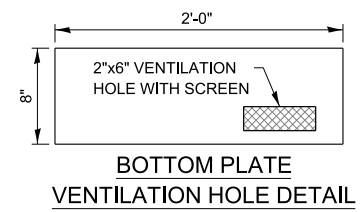

**NOTES:**

- LABEL JUNCTION BOX, TERMINAL STRIPS, AND ALL WIRE AND CABLES.
- ROUTE 1-2/C #12 POWER CABLE TO EACH CAMERA.
- ALL ELECTRICAL CABLES TO CAMERA SHALL HAVE SURGE PROTECTION.
- CAT6 CABLE SHALL BE SURGE PROTECTED ON THE TSIC.



**VIDEO POWER JUNCTION BOX DETAIL - MAIN PLAZA**

VERSION: 2026-03      BASE SHEET: M-BUS-2516      SHEET: 1 OF 1

**NOTES:**

1. SEE CABLE AND CONDUIT SCHEDULE. SHEET FOR CABLE TAGS.
2. SEE AET WIRING DIAGRAMS SHEET FOR MONOTUBE WIRING.
3. NOT USED.
4. CAP ALL CONDUIT STUBS FOR FUTURE USE.
5. FINAL LOCATION OF ALL HANDHOLES AND JUNCTION BOXES SHALL BE APPROVED BY THE ENGINEER.
6. NOT USED.
7. ROUTE PLAZA ROADWAY LIGHTING CIRCUITS TO LIGHTING CONTRACTOR, THESE STAY ON PLAZA CIRCUITS, THAT ARE POWERED FROM PLAZA EMERGENCY GENERATOR. ROUTE 2-1/C #8 AND 1/C #8 GROUND WIRE FROM LIGHTING CONTRACTOR LOCATED IN THE POWER CABINET TO THE LIGHT POLE FOR PLAZA LIGHTING CONTROL CIRCUIT. PROVIDE PHOTOCELL ON SAME POLE.
8. ALL EXCESS (SLACK) POWER AND DATA CABLES MUST BE COILED IN THE HANDHOLE. NO EXCESS CABLE WILL BE COILED INSIDE THE BUILDING.
9. EXOTHERMICALLY WELD THE GROUND WIRE TO THE MONOTUBE'S BASE.
10. REFER TO TSIC TERMINAL BLOCK LAYOUT SHEET. LOW VOLTAGE WIRE FROM VES AND SECURITY CAMERAS LAND ON SURGE PROTECTION DEVICES.
11. PVC CONDUIT SHALL BE USED WHEN THE CONDUIT IS EITHER COVERED OR ENCASED IN CONCRETE. ANY EXPOSED CONDUIT SHALL BE PVC COATED RGS. SLEEVES SHALL BE USED WHEN CROSSING WALL FOUNDATIONS.
12. LOCATION OF LANE STUB UPS TO BE APPROVED BY THE ILLINOIS TOLLWAY PRIOR TO CONCRETE POUR. FINAL LOCATION OF EQUIPMENT TO BE APPROVED BY THE ENGINEER.
13. PROVIDE (2) 4" PVC COATED RGS 5FT PAST RETAINING WALL UP TO ComEd TRANSFORMER FOR ComEd INCOMING PRIMARY CABLES. INSTALL SLEEVE IN COORDINATION WITH STRUCTURAL AND STUB UP NEAR ComEd TRANSFORMER LOCATION. PROVIDE WATER PROOF SEALING AT RETAINING WALL.
14. RIGID METALLIC CONDUIT PVC COATED FOR MONOTUBE POWER/DATA/ANTENNA CABLING SHALL RUN IN OVERHEAD CONDUIT TRAY. SEE OVERHEAD CONDUIT TRAY DETAILS..
15. SEE VES CAMERA WASH SYSTEM SHEETS FOR DETAILS. THIS WORK WILL BE PAID UNDER PAY ITEM JT132701 "VES CAMERA HIGH PRESSURE WASH SYSTEM, LOCATION 2".
16. FOR LIGHT POLE AND FOUNDATION DETAILS, SEE ILLINOIS TOLLWAY STANDARD DRAWINGS H1 AND H2.
17. NOT USED.
18. PROVIDE (2) 6" SDR 11 HDPE SLEEVES, EACH SLEEVE SHALL HAVE:  
 (1) 1 1#2" CNC DUCT (SOLID GREEN)  
 (1) 1 1#2" CNC DUCT (GREEN/WHITE STRIPE)  
 (1) 1 1#2" CNC DUCT (BLACK/RED STRIPE)

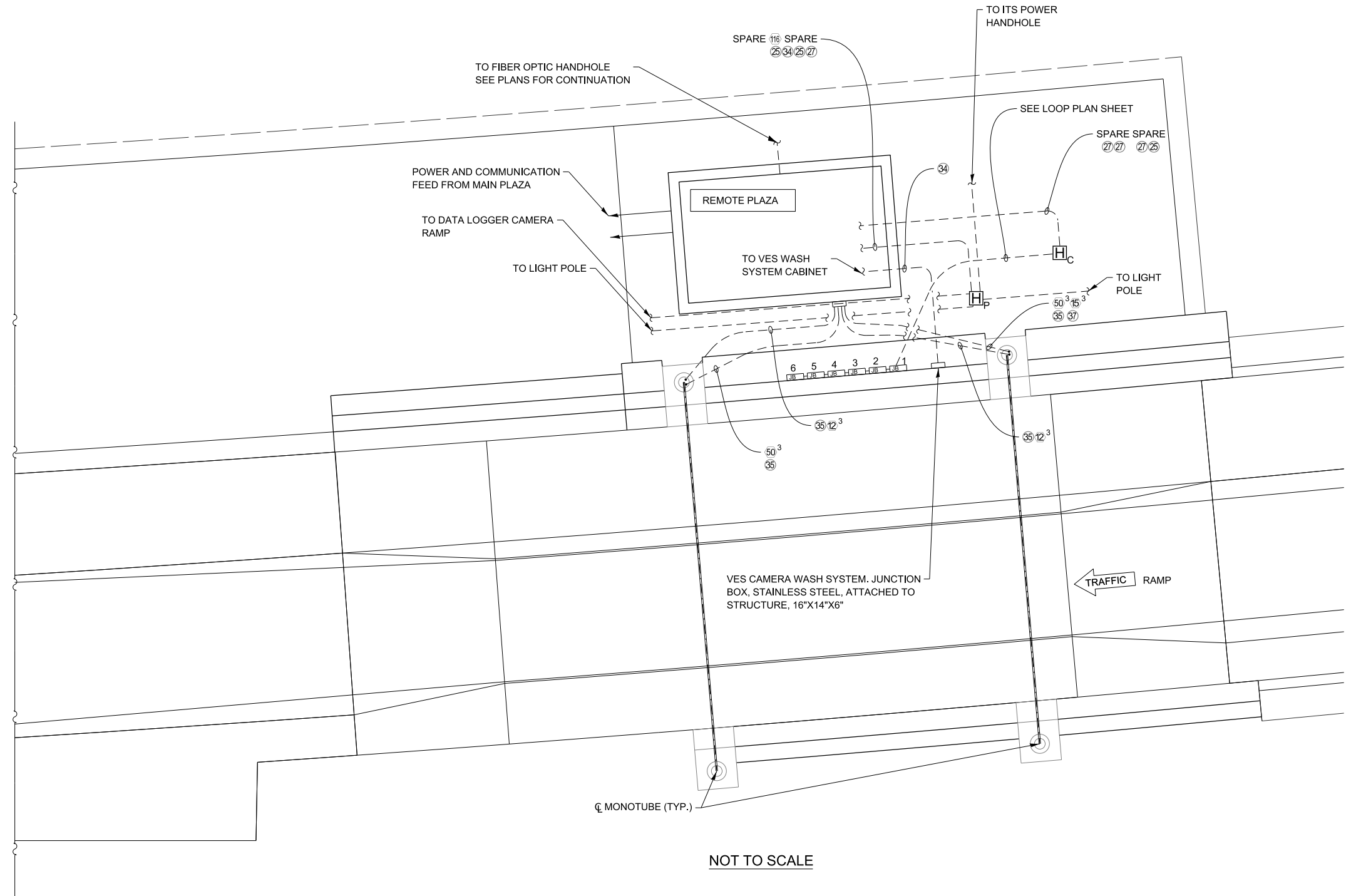

NOT TO SCALE

**NOTE TO DESIGNER**

THIS BASE SHEET SHOWS TYPICAL CONSTRUCTION BUT IT IS NOT A STANDARD DRAWING. IT REQUIRES COMPLETION BY THE DESIGNER PRIOR TO INSERTION INTO A CONTRACT. MICROSTATION FILES AND THE "CADD STANDARDS MANUAL" ARE AVAILABLE ON THE ILLINOIS TOLLWAY WEBSITE. THE DESIGNER SHALL ACCEPT THE RESPONSIBILITY OF THE DESIGN OF THIS SHEET UPON ITS COMPLETION AND INSERTION INTO A CONTRACT. ALL "NOTE TO DESIGNER" BOXES SHALL BE REMOVED BY THE DESIGNER PRIOR TO INSERTION OF THE SHEET INTO THE PLAN SET.



**UNDERGROUND CONDUIT PLAN - REMOTE PLAZA**

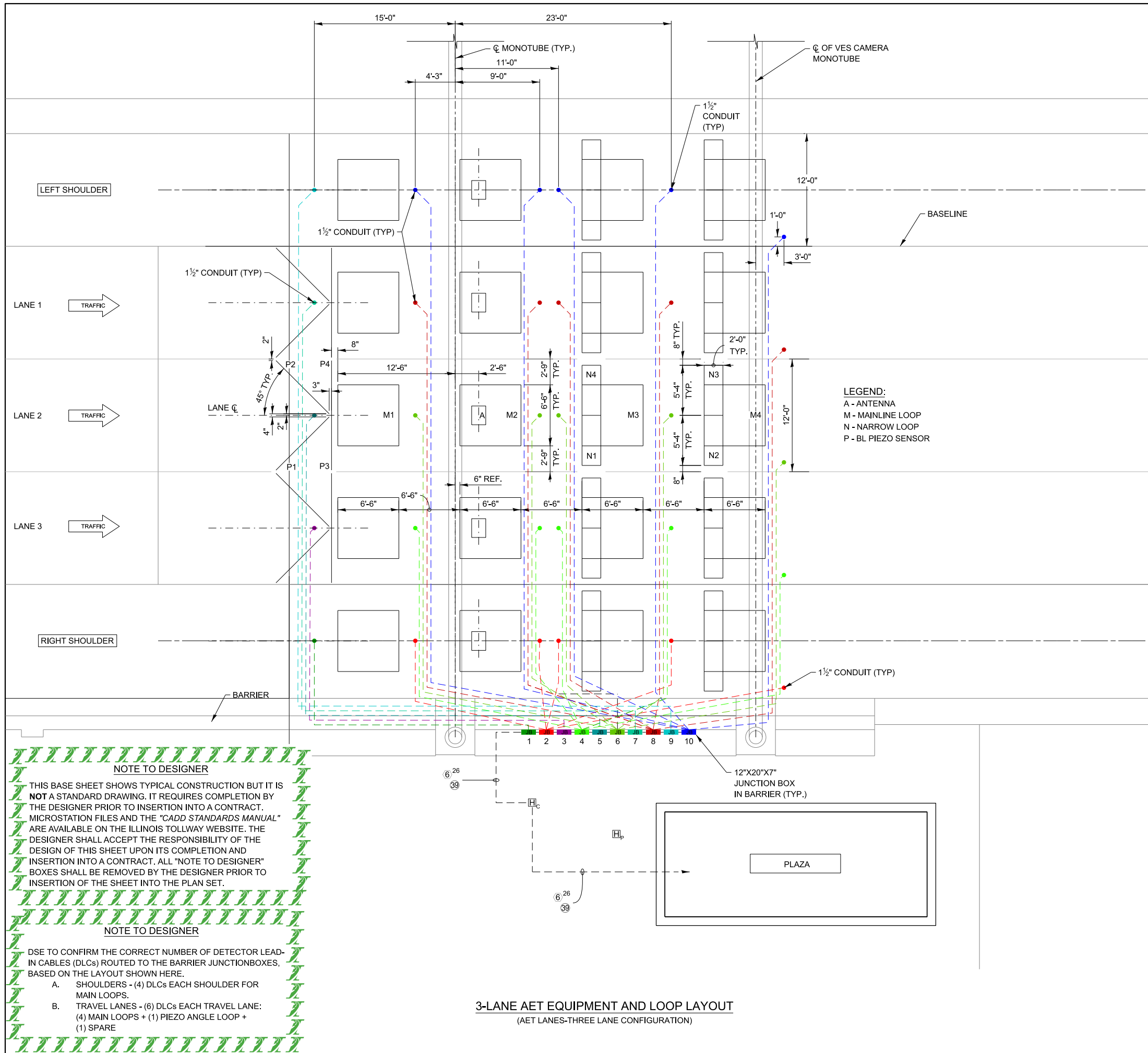

- NOTES:**
1. MINIMUM CONDUIT SIZE IS 1-1/2".
  2. LOOP WIRE SPLICES ARE MADE IN JUNCTION BOXES.
  3. CONDUITS FOR LOOPS ARE TO BE 1-1/2" RIGID GALVANIZED STEEL PVC COATED.
  4. LOOPS PROVIDED AND INSTALLED BY THE ILLINOIS TOLLWAY. LOOPS PULLED BACK TO JUNCTION BOXES IN BARRIER WALL. SEE LOOP INSTALLATION DETAILS. CONTRACTOR SHALL COORDINATE WITH ILLINOIS TOLLWAY FOR PROVIDING SLOT OPENING, SAW CUTTING AND OTHER MISCELLANEOUS WORK REQUIRED FOR COMPLETE LOOP INSTALLATION.
  5. VERIFY THE CONDUIT, MONOTUBES AND VES CAMERA POLE LOCATIONS WITH THE ILLINOIS TOLLWAY PRIOR TO BARRIER CONSTRUCTION.
  6. EQUIPMENT LOCATIONS MUST BE VERIFIED BY THE ILLINOIS TOLLWAY PRIOR TO ANY CONSTRUCTION STARTING. LOCATION OF ALL LANE LOOPS AND LANE STUB UPS SHALL BE APPROVED BY THE ILLINOIS TOLLWAY BEFORE CONCRETE POUR CONTRACTOR TO COORDINATE WITH THE ENGINEER.
  7. SEE CONDUIT ROUTING DETAILS.
  8. CONTRACTOR IS TO PROVIDE ALL CONDUIT AND LOOP LEAD IN CABLE FROM BUILDING TO JUNCTION BOX IN BARRIER WALL. 3 FEET OF CABLE COILED IN JUNCTION BOX AT BARRIER WALL.
  9. ALL LOOP DETECTORS SHALL BE IN THE CENTER OF THE STRIPED LANES.
  10. CONDUITS AND CONDUIT STUB UPS SHOWN SHALL BE INSTALLED IN ALL LANES (TRAVEL LANES AND SHOULDERS).
  11. LEAD EDGE OF LOOP 2 SHALL BE 6" DOWNSTREAM OF MONOTUBE CENTERLINE.
  12. PIEZO AND QUANTUM SYSTEM LOOPS SHALL BE INSTALLED IN TRAVEL LANES ONLY.

**LEGEND:**  
 A - ANTENNA  
 M - MAINLINE LOOP  
 N - NARROW LOOP  
 P - BL PIEZO SENSOR

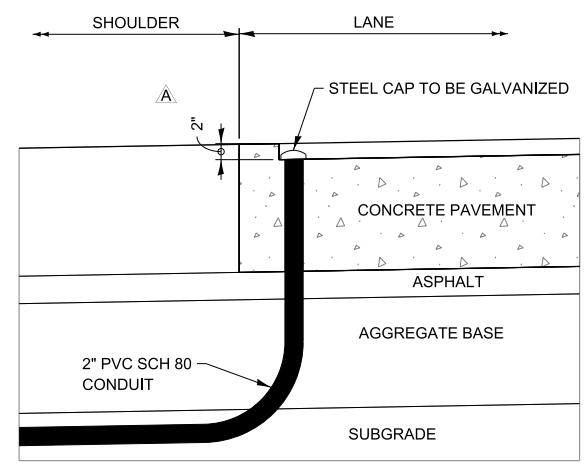

**NOTE TO DESIGNER**

THIS BASE SHEET SHOWS TYPICAL CONSTRUCTION BUT IT IS NOT A STANDARD DRAWING. IT REQUIRES COMPLETION BY THE DESIGNER PRIOR TO INSERTION INTO A CONTRACT. MICROSTATION FILES AND THE "CADD STANDARDS MANUAL" ARE AVAILABLE ON THE ILLINOIS TOLLWAY WEBSITE. THE DESIGNER SHALL ACCEPT THE RESPONSIBILITY OF THE DESIGN OF THIS SHEET UPON ITS COMPLETION AND INSERTION INTO A CONTRACT. ALL "NOTE TO DESIGNER" BOXES SHALL BE REMOVED BY THE DESIGNER PRIOR TO INSERTION OF THE SHEET INTO THE PLAN SET.

**NOTE TO DESIGNER**

DSE TO CONFIRM THE CORRECT NUMBER OF DETECTOR LEAD-IN CABLES (DLCs) ROUTED TO THE BARRIER JUNCTIONBOXES, BASED ON THE LAYOUT SHOWN HERE.

- A. SHOULDERS - (4) DLCs EACH SHOULDER FOR MAIN LOOPS.
- B. TRAVEL LANES - (6) DLCs EACH TRAVEL LANE: (4) MAIN LOOPS + (1) PIEZO ANGLE LOOP + (1) SPARE

**3-LANE AET EQUIPMENT AND LOOP LAYOUT**  
 (AET LANES-THREE LANE CONFIGURATION)

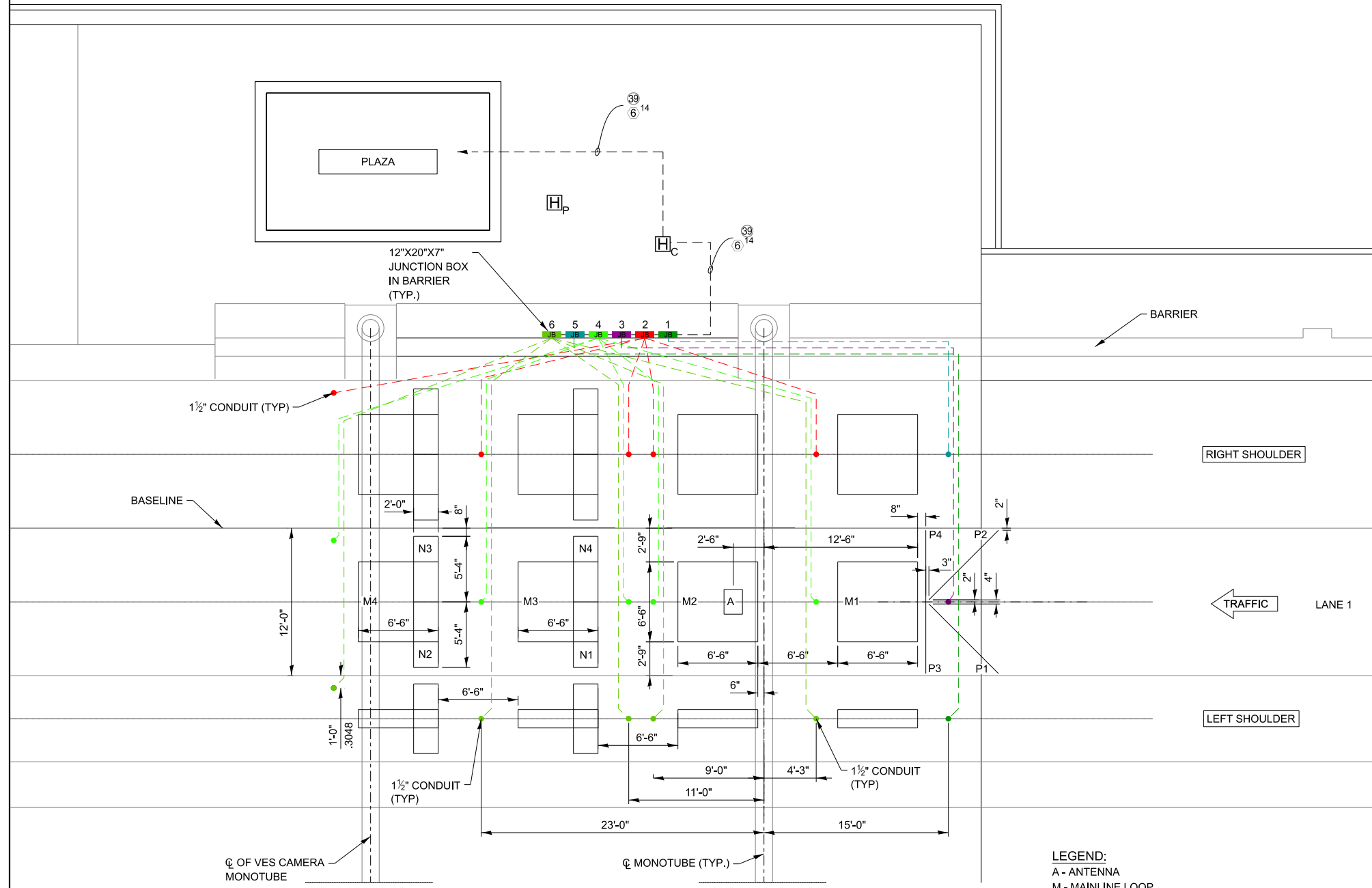

**NOTES:**

1. MINIMUM CONDUIT SIZE IS 1-1/2".
2. LOOP WIRE SPLICES ARE MADE IN JUNCTION BOXES.
3. CONDUITS FOR LOOPS ARE TO BE 1-1/2" RIGID GALVANIZED STEEL PVC COATED.
4. LOOPS PROVIDED AND INSTALLED BY THE ILLINOIS TOLLWAY. LOOPS PULLED BACK TO JUNCTION BOXES IN BARRIER WALL. SEE LOOP INSTALLATION DETAILS. CONTRACTOR SHALL COORDINATE WITH ILLINOIS TOLLWAY FOR PROVIDING SLOT OPENING, SAW CUTTING AND OTHER MISCELLANEOUS WORK REQUIRED FOR COMPLETE LOOP INSTALLATION.
5. VERIFY THE CONDUIT, MONOTUBES AND VES CAMERA POLE LOCATIONS WITH THE ILLINOIS TOLLWAY PRIOR TO BARRIER CONSTRUCTION.
6. EQUIPMENT LOCATIONS MUST BE VERIFIED BY THE ILLINOIS TOLLWAY PRIOR TO ANY CONSTRUCTION STARTING. LOCATION OF ALL LANE LOOPS AND LANE STUB UPS SHALL BE APPROVED BY THE ILLINOIS TOLLWAY BEFORE CONCRETE POUR CONTRACTOR TO COORDINATE WITH THE ENGINEER.
7. SEE CONDUIT ROUTING DETAILS.
8. CONTRACTOR IS TO PROVIDE ALL CONDUIT AND LOOP LEAD IN CABLE FROM BUILDING TO JUNCTION BOX IN BARRIER WALL. 3 FEET OF CABLE COILED IN JUNCTION BOX AT BARRIER WALL.
9. ALL LOOP DETECTORS SHALL BE IN THE CENTER OF THE STRIPED LANES.
10. CONDUITS AND CONDUIT STUB UPS SHOWN SHALL BE INSTALLED IN ALL LANES (TRAVEL LANES AND SHOULDERS).
11. LEAD EDGE OF LOOP 2 SHALL BE 6" DOWNSTREAM OF MONOTUBE CENTERLINE.
12. PIEZO AND QUANTUM SYSTEM LOOPS SHALL BE INSTALLED IN TRAVEL LANES ONLY.

**NOTE TO DESIGNER**

THIS BASE SHEET SHOWS TYPICAL CONSTRUCTION BUT IT IS NOT A STANDARD DRAWING. IT REQUIRES COMPLETION BY THE DESIGNER PRIOR TO INSERTION INTO A CONTRACT. MICROSTATION FILES AND THE "CADD STANDARDS MANUAL" ARE AVAILABLE ON THE ILLINOIS TOLLWAY WEBSITE. THE DESIGNER SHALL ACCEPT THE RESPONSIBILITY OF THE DESIGN OF THIS SHEET UPON ITS COMPLETION AND INSERTION INTO A CONTRACT. ALL "NOTE TO DESIGNER" BOXES SHALL BE REMOVED BY THE DESIGNER PRIOR TO INSERTION OF THE SHEET INTO THE PLAN SET.

**NOTE TO DESIGNER**

DSE TO CONFIRM THE CORRECT NUMBER OF DETECTOR LEAD-IN CABLES (DLCs) ROUTED TO THE BARRIER JUNCTION BOXES, BASED ON THE LAYOUT SHOWN HERE.

A. SHOULDERS - (4) DLCs EACH SHOULDER FOR MAIN LOOPS.

B. TRAVEL LANES - (6) DLCs EACH TRAVEL LANE: (4) MAIN LOOPS + (1) PIEZO ANGLE LOOP + (1) SPARE

**LEGEND:**  
 A - ANTENNA  
 M - MAINLINE LOOP  
 N - NARROW LOOP  
 P - BL PIEZO SENSOR

**1-LANE AET EQUIPMENT AND LOOP LAYOUT**

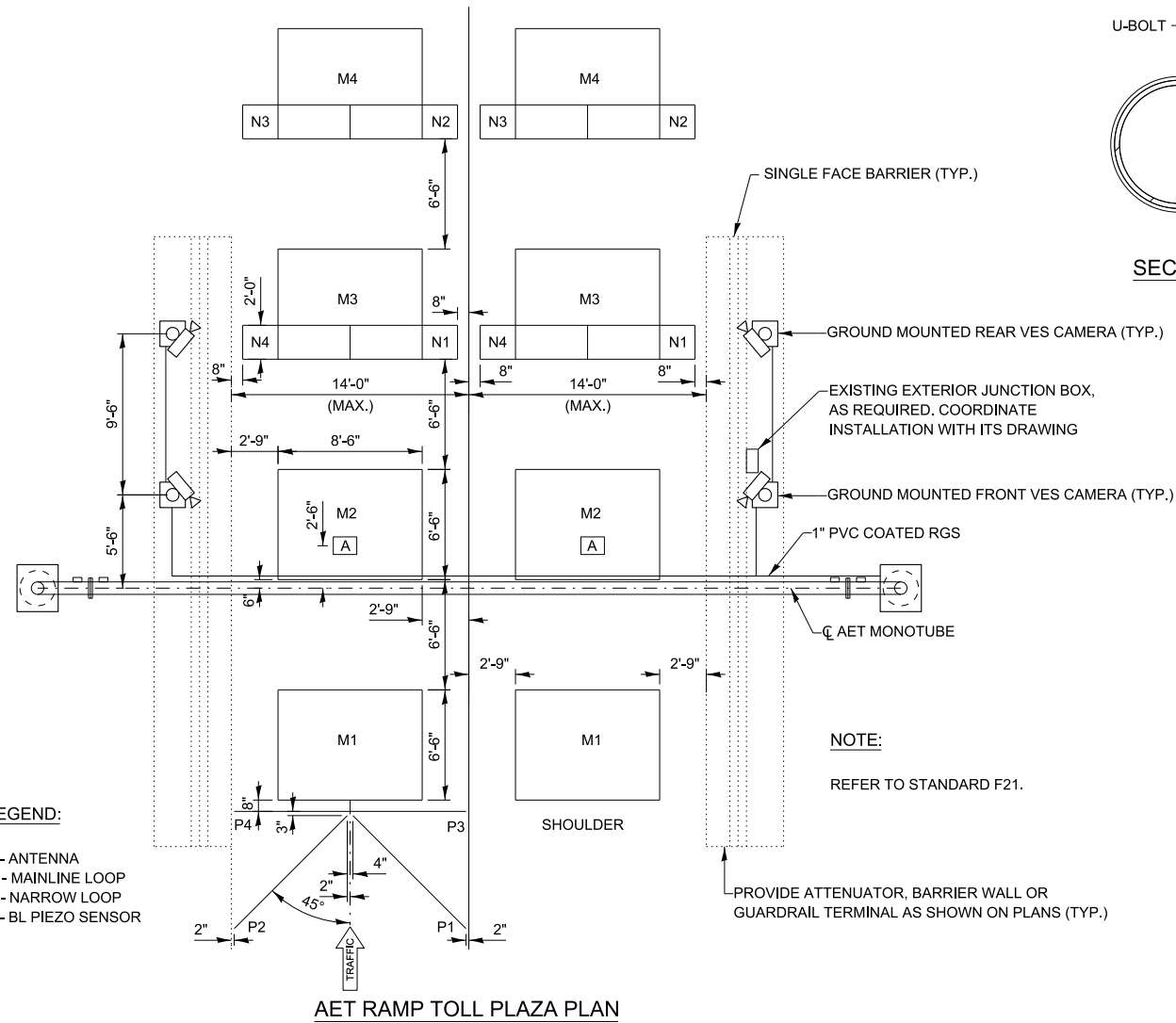

**AET RAMP TOLL PLAZA PLAN**

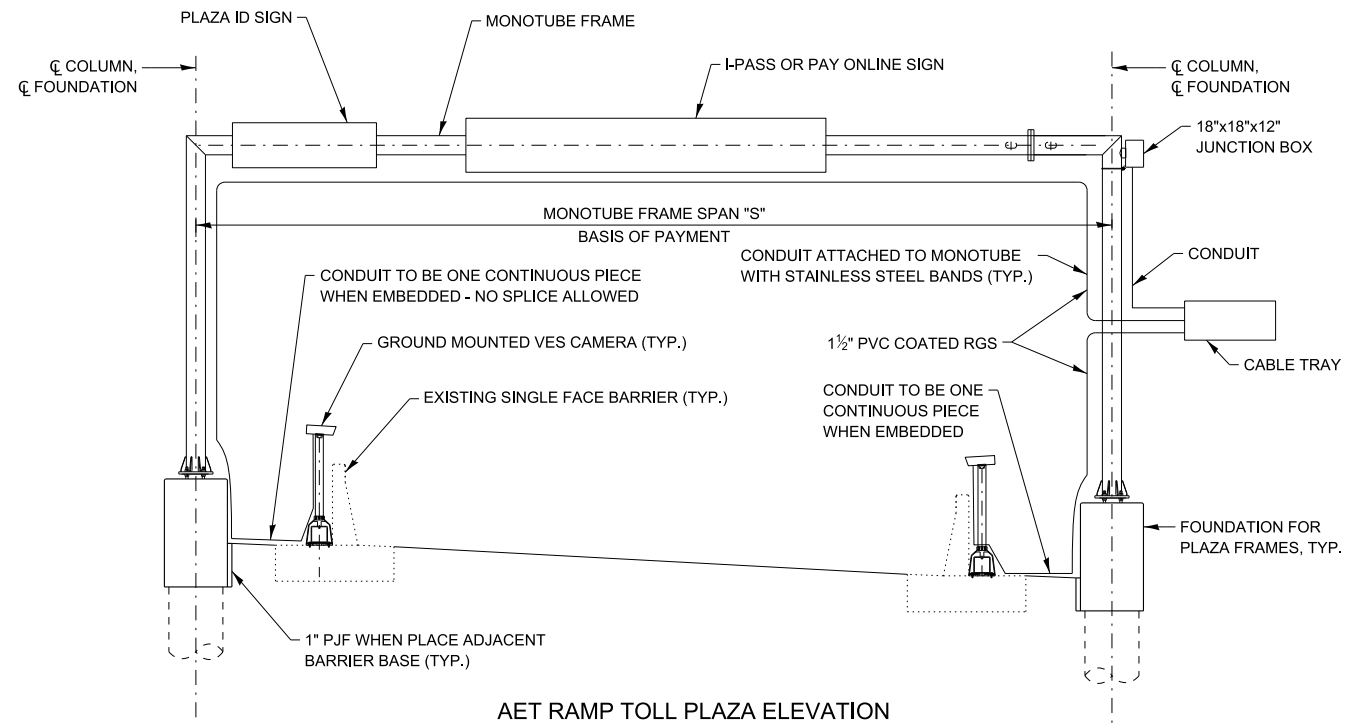

**AET RAMP TOLL PLAZA ELEVATION**

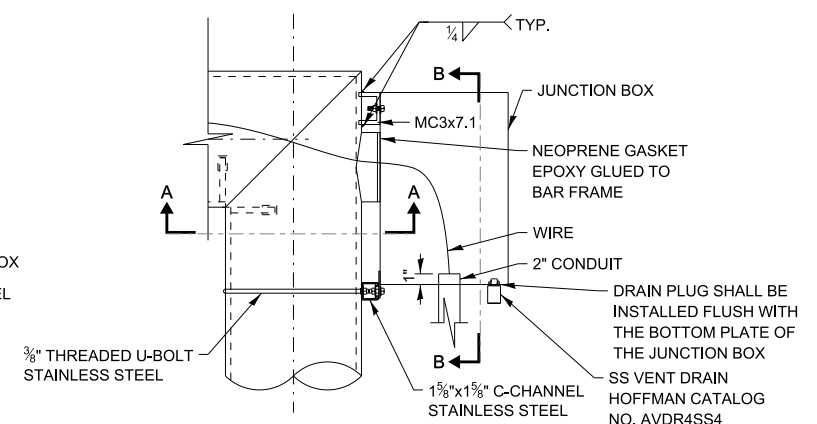
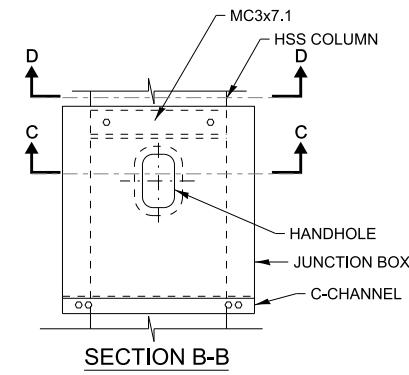
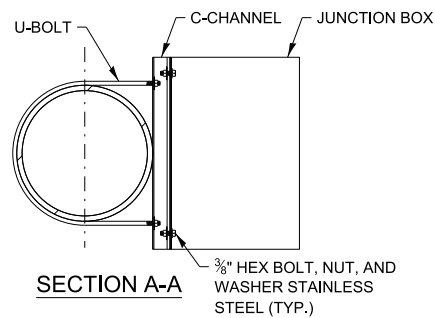

**JUNCTION BOX ATTACHMENT**

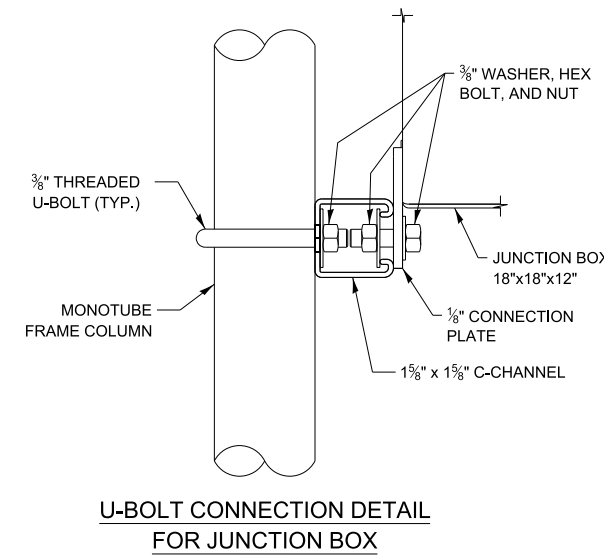
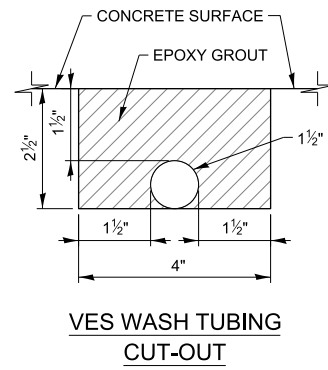
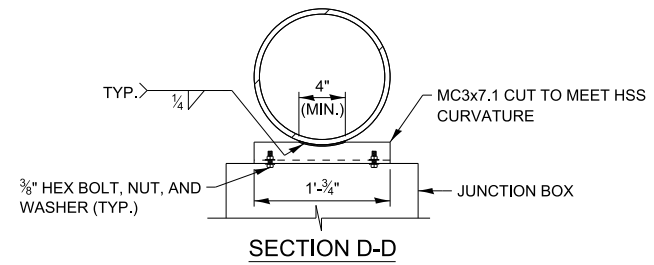
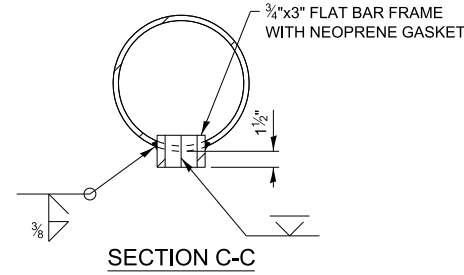

**NOTE:**  
 EPOXY GLUE TO GLUE THE NEOPRENE GASKET ON THE SURFACE OF THE HANDHOLE SHALL BE FOR OUTDOOR USE WITH A TEMPERATURE RANGE OF -20°F TO 150°F AND SHALL BE SUITABLE FOR METAL AND PLASTIC WITH A SHEAR STRENGTH GREATER THAN 2300 PSI.

**HANDHOLE AND HIGH DENSITY NEOPRENE GASKET**  
 1/2" UNCOMPRESSED, WHEN COMPRESSED 1/4" THICK

**NOTE TO DESIGNER**  
 THIS BASE SHEET SHOWS TYPICAL CONSTRUCTION BUT IT IS NOT A STANDARD DRAWING. IT REQUIRES COMPLETION BY THE DESIGNER PRIOR TO INSERTION INTO A CONTRACT. MICROSTATION FILES AND THE "CADD STANDARDS MANUAL" ARE AVAILABLE ON THE ILLINOIS TOLLWAY WEBSITE. THE DESIGNER SHALL ACCEPT THE RESPONSIBILITY OF THE DESIGN OF THIS SHEET UPON ITS COMPLETION AND INSERTION INTO A CONTRACT. ALL "NOTE TO DESIGNER" BOXES SHALL BE REMOVED BY THE DESIGNER PRIOR TO INSERTION OF THE SHEET INTO THE PLAN SET.

**NOTE TO DESIGNER**  
 DSE TO CONFIRM THE CORRECT NUMBER OF DETECTOR LEAD-IN CABLES (DLCs) ROUTED TO THE BARRIER JUNCTION BOXES, BASED ON THE LAYOUT SHOWN HERE.  
 A. SHOULDERS - (4) DLCs EACH SHOULDER FOR MAIN LOOPS.  
 B. TRAVEL LANES - (6) DLCs EACH TRAVEL LANE: (4) MAIN LOOPS + (1) PIEZO ANGLE LOOP + (1) SPARE



**LOOP PLAN - AET 1-LANE LAYOUT SINGLE MONOTUBE**

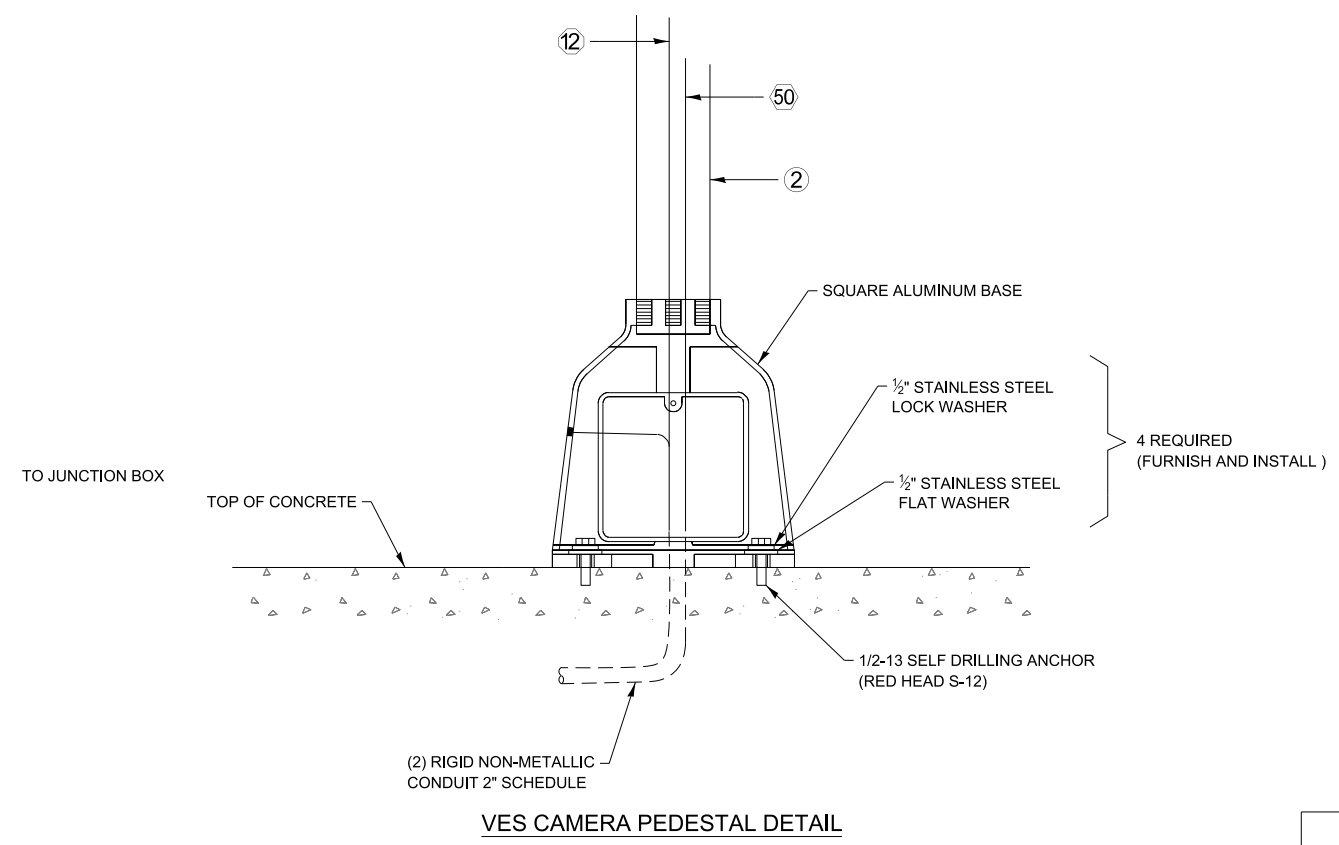
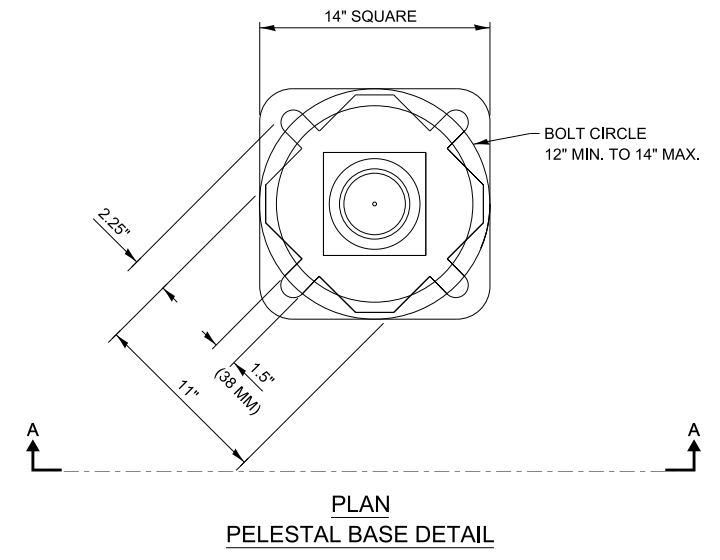
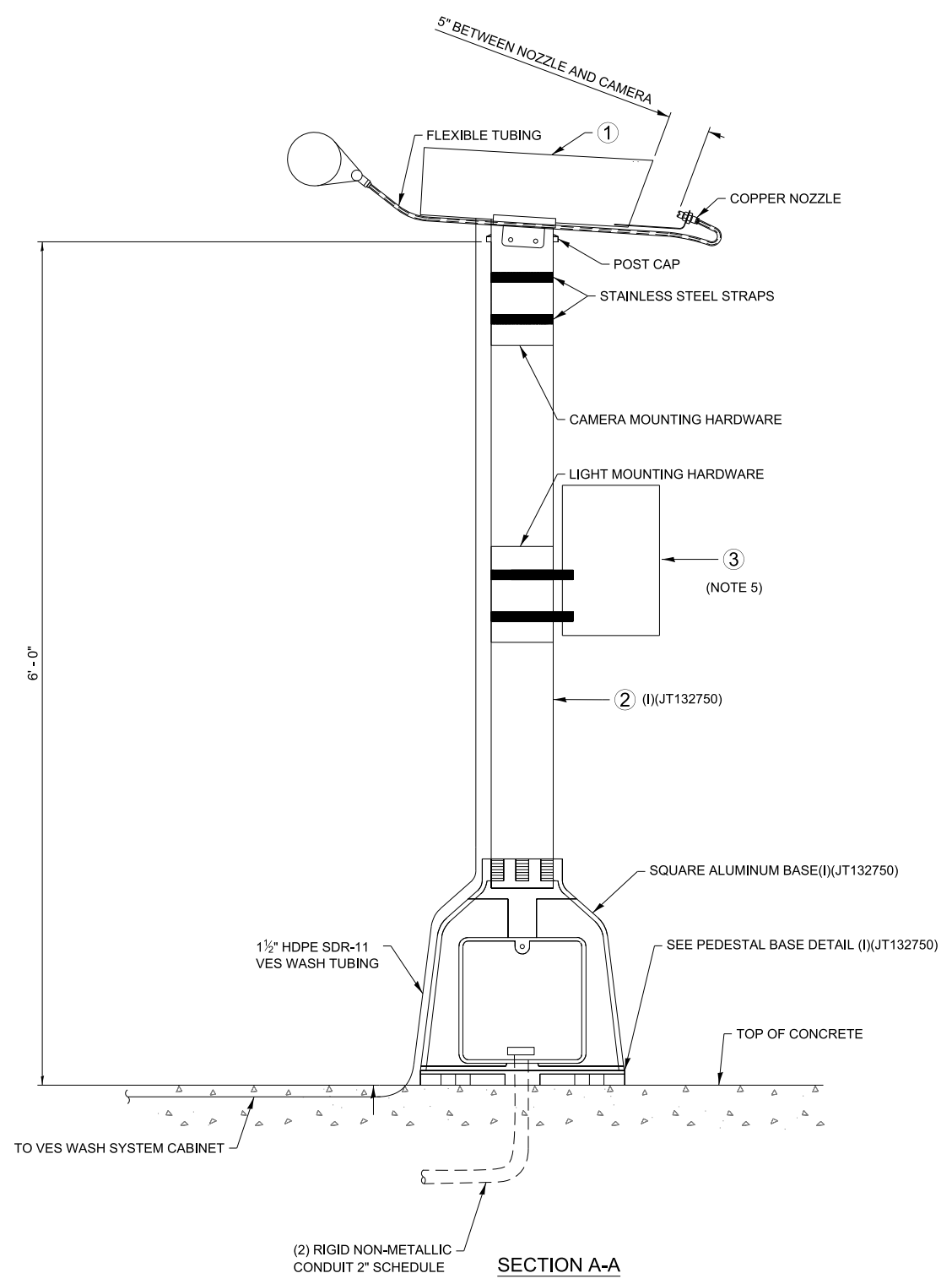

**NOTES:**

1. REFER TO TOLL EQUIPMENT WIRING DIAGRAM.
2. VIOLATION CAMERAS SHALL BE INSTALLED BY THE TOLLWAY.
3. USE GALVANIZED STEEL SHIMS UNDER THE BASE PLATE TO PLUMB THE CAMERA PEDESTAL.
4. THE GROUND WIRE MUST BE EXOTHERMICALLY WELDED OR MECHANICALLY BONDED TO THE CAMERA PEDESTAL AS DIRECTED BY THE ENGINEER.
5. NEW STROBE ILLUMINATOR.

**EQUIPMENT LEGEND**

ITEM	DESCRIPTION
①	CAMERA FURNISHED AND INSTALLED BY THE TOLLWAY.
②	4" ALUMINIUM POST.
③	TRAFFIC WHITE LIGHT ILLUMINATOR



**GROUND MOUNTED VES CAMERA WITH VES WASH TUBING**

**NOTES:**

- SEE CABLE/CONDUIT SCHEDULE AND NOTES SHEET FOR CABLE TAGS.
- FRONT AND REAR VES CAMERA CABLES ARE PULLED BY THE CONTRACTOR INTO MONOTUBE AND POLE ARM. THE CONTRACTOR WHIPS UP ABOUT 10 FEET OF CABLE, LEAVING THE MAJORITY INSIDE THE MONOTUBE/POLE ARM. THE ILLINOIS TOLLWAY WILL PULL FROM THE JB/POLE ARM TO THE CAMERAS AND THEN TERMINATE.
- VES CAMERA NUMBERING SCHEME BEGIN AT RIGHT SHOULDER AND ARE ORDERED SEQUENTIALLY (1, 2, 3, ... ETC) TO LEFT SHOULDER.
- ALL CABINETS AND POWER PANEL LOCATED IN CONTROL BUILDING.
- COAX FOR AVI ANTENNAS ROUTE THROUGH 2" TO 1" COUPLER (IF REQUIRED), THEN RUN IN 1" SEALTITE CONDUIT TO ANTENNA.
- EQUIPMENT LOCATIONS MUST BE VERIFIED BY THE ILLINOIS TOLLWAY PRIOR TO CONSTRUCTION AND INSTALLATION.
- IF VES CAMERAS ARE MOUNTED 18' ABOVE THE ROADWAY, THEN THE CAMERAS SHALL BE PLACED 33' HORIZONTAL FROM THE TRIGGER.
- THIS CABLING IS USED TO POWER THE VES CAMERAS. THESE CABLES WILL RUN FROM A 24V DC POWER SUPPLY LOCATED IN THE VPJB.
- DATA LOGGER CAMERA SHALL BE PLACED DOWNSTREAM OF THE EXITING MONOTUBE ON A NON-BREAKAWAY DEDICATED ITS POLE. DATA LOGGER CAMERA POWER AND SIGNAL WILL GO THROUGH CAT 6 ETHERNET CABLE. MOUNT DATA LOGGER CAMERA AT 20'.
- 1.5" SEALTITE AND FITTINGS ARE FURNISHED BY THE CONTRACTOR AND INSTALLED BY THE ILLINOIS TOLLWAY.
- ALL WIRING FROM CAMERAS/I-PASS ANTENNAS SHALL BE SURGE PROTECTED AS IT ENTERS PLAZA BUILDING. SURGE PROTECTION SHALL BE IN VES VPJB FOR CAMERAS AND IN COMMUNICATION ROOM FOR ANTENNA CABLE.
- PROVIDE 14 FT PERPENDICULAR OUTRIGGER SUPPORT FOR VES CAMERA POLE AND THE ANTENNA POLE DUE TO THE NEEDS OF MULTIPROTOCOL READERS ONLY. MAINTAIN THE POSITION OF THE VES SUPPORT POLE SO THE LONGER OUTRIGGER WILL NEED TO CANTILEVER MORE TOWARDS THE DEPARTURE SIDE OF THE MONOTUBE.
- NOT USED.
- CONTRACTOR SHALL FURNISH AND INSTALL JUNCTION BOX 12"x12"x6" TYPE NEMA 4X. (HOFFMAN A1212CHNFSS) ON DOWNSTREAM SIDE OF THE ENTRANCE AND EXIT MONOTUBES FOR TERMINATION OF POWER AND COMMUNICATION CABLES. SEE STRUCTURAL DRAWINGS FOR LOCATION.
- REAR PLATE CAMERAS ARE MOUNTED 2'-6" UPSTREAM FROM C/L OF MONOTUBE AND AVI ANTENNAS ARE MOUNTED 2'-6" DOWNSTREAM FROM C/L OF MONOTUBE.

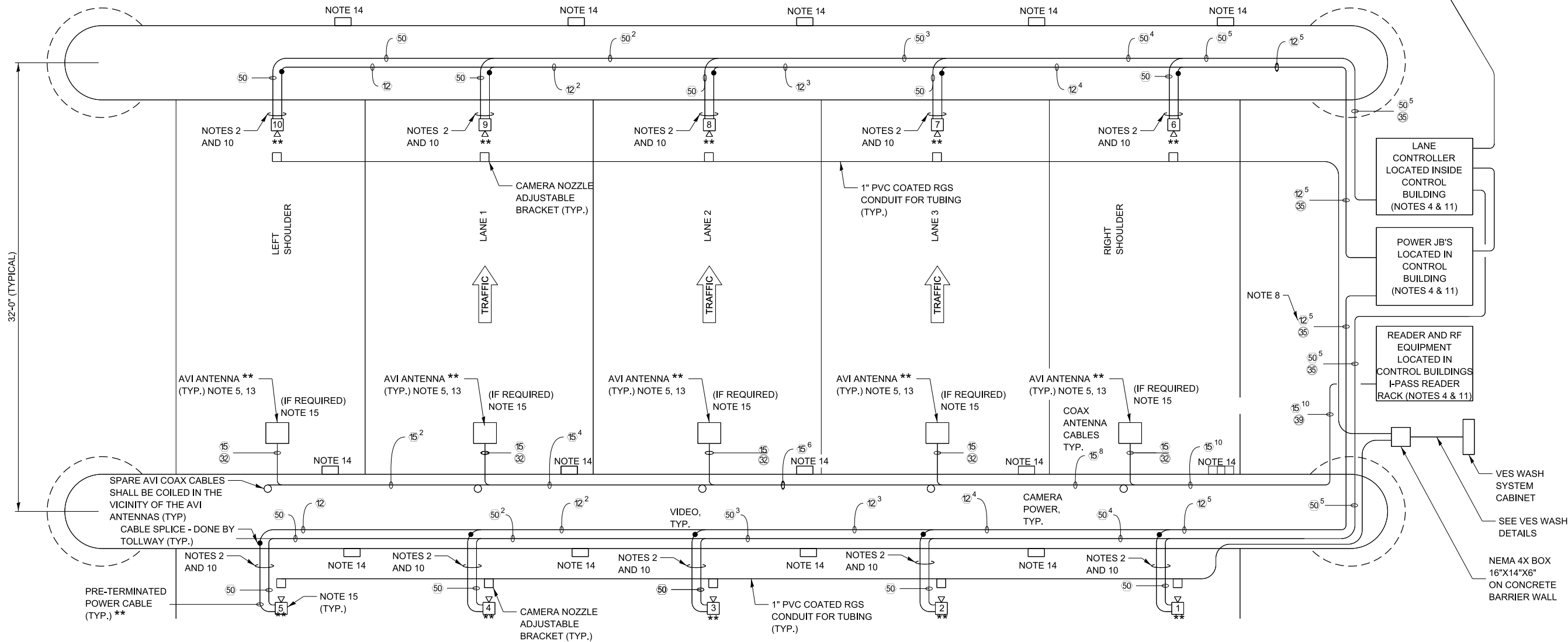

**FRONT - REAR PLATE VES BLOCK WIRING DIAGRAM**

**NOTE TO DESIGNER**

THIS BASE SHEET SHOWS TYPICAL CONSTRUCTION BUT IT IS NOT A STANDARD DRAWING. IT REQUIRES COMPLETION BY THE DESIGNER PRIOR TO INSERTION INTO A CONTRACT. MICROSTATION FILES AND THE "CADD STANDARDS MANUAL" ARE AVAILABLE ON THE ILLINOIS TOLLWAY WEBSITE. THE DESIGNER SHALL ACCEPT THE RESPONSIBILITY OF THE DESIGN OF THIS SHEET UPON ITS COMPLETION AND INSERTION INTO A CONTRACT. ALL "NOTE TO DESIGNER" BOXES SHALL BE REMOVED BY THE DESIGNER PRIOR TO INSERTION OF THE SHEET INTO THE PLAN SET.

**NOTE TO DESIGNER**

VES CAMERAS ON SHOULDERS ARE NOT TYPICALLY INSTALLED. SHOWN HERE FOR COMPLETION, BUT SHOULD BE REMOVED BY DESIGNER UNLESS THEY ARE SPECIFICALLY REQUESTED BY ILLINOIS TOLLWAY.

- LEGEND:**
- \* INDICATES EQUIPMENT FURNISHED BY THE ILLINOIS TOLLWAY AND INSTALLED BY THE CONTRACTOR.
  - \*\* INDICATES EQUIPMENT FURNISHED AND INSTALLED BY THE ILLINOIS TOLLWAY.
  - INDICATES EQUIPMENT FURNISHED AND INSTALLED BY THE CONTRACTOR.

**WIRING DIAGRAM - AET 3-LANE LAYOUT**

VERSION: 2021-03      BASE SHEET: M-BUS-2519A      SHEET: 1 OF 1

**NOTES:**

1. SEE CABLE/CONDUIT SCHEDULE AND NOTES SHEET FOR CABLE TAGS.
2. FRONT AND REAR VES CAMERA CABLES ARE PULLED BY THE CONTRACTOR INTO MONOTUBE AND POLE ARM. THE CONTRACTOR WHIPS UP ABOUT 10 FEET OF CABLE, LEAVING THE MAJORITY INSIDE THE MONOTUBE/POLE ARM. THE ILLINOIS TOLLWAY WILL PULL FROM THE JB/POLE ARM TO THE CAMERAS AND THEN TERMINATE.
3. VES CAMERA NUMBERING SCHEME BEGIN AT RIGHT SHOULDER AND ARE ORDERED SEQUENTIALLY (1, 2, 3, ... ETC) TO LEFT SHOULDER.
4. ALL CABINETS AND POWER PANEL LOCATED IN CONTROL BUILDING.
5. COAX FOR AVI ANTENNAS ROUTE THROUGH 2" TO 1" COUPLER (IF REQUIRED), THEN RUN IN 1" SEALTITE CONDUIT TO ANTENNA.
6. EQUIPMENT LOCATIONS MUST BE VERIFIED BY THE ILLINOIS TOLLWAY PRIOR TO CONSTRUCTION AND INSTALLATION.
7. IF VES CAMERAS ARE MOUNTED 18' ABOVE THE ROADWAY, THEN THE CAMERAS SHALL BE PLACED 33' HORIZONTAL FROM THE TRIGGER.
8. THIS CABLING IS USED TO POWER THE VES CAMERAS. THESE CABLES WILL RUN FROM A 24V DC POWER SUPPLY LOCATED IN THE VPJB.
9. DATA LOGGER CAMERA SHALL BE PLACED DOWNSTREAM OF THE EXITING MONOTUBE ON A NON-BREAKAWAY DEDICATED ITS POLE. DATA LOGGER CAMERA POWER AND SIGNAL WILL GO THROUGH CAT 6 ETHERNET CABLE. MOUNT DATA LOGGER CAMERA AT 20'.
10. 1.5" SEALTITE AND FITTINGS ARE FURNISHED BY THE CONTRACTOR AND INSTALLED BY THE ILLINOIS TOLLWAY.
11. ALL WIRING FROM CAMERAS/I-PASS ANTENNAS SHALL BE SURGE PROTECTED AS IT ENTERS PLAZA BUILDING. SURGE PROTECTION SHALL BE IN VES VPJB FOR CAMERAS AND IN COMMUNICATION ROOM FOR ANTENNA CABLE.
12. PROVIDE 14 FT PERPENDICULAR OUTRIGGER SUPPORT FOR VES CAMERA POLE AND THE ANTENNA POLE DUE TO THE NEEDS OF MULTIPROTOCOL READERS ONLY. MAINTAIN THE POSITION OF THE VES SUPPORT POLE SO THE LONGER OUTRIGGER WILL NEED TO CANTILEVER MORE TOWARDS THE DEPARTURE SIDE OF THE MONOTUBE.
13. NOT USED.
14. CONTRACTOR SHALL FURNISH AND INSTALL JUNCTION BOX 12"x12"x6" TYPE NEMA 4X, HOFFMAN A1212CHNFSS ON DOWNSTREAM SIDE OF THE ENTRANCE AND EXIT MONOTUBES FOR TERMINATION OF POWER AND COMMUNICATION CABLES (EXCEPT AVI CABLES). SEE STRUCTURAL DRAWINGS FOR LOCATION.
15. REAR PLATE CAMERAS ARE MOUNTED 2'-6" UPSTREAM FROM C/L OF MONOTUBE AND AVI ANTENNAS ARE MOUNTED 2'-6" DOWNSTREAM FROM C/L OF MONOTUBE.

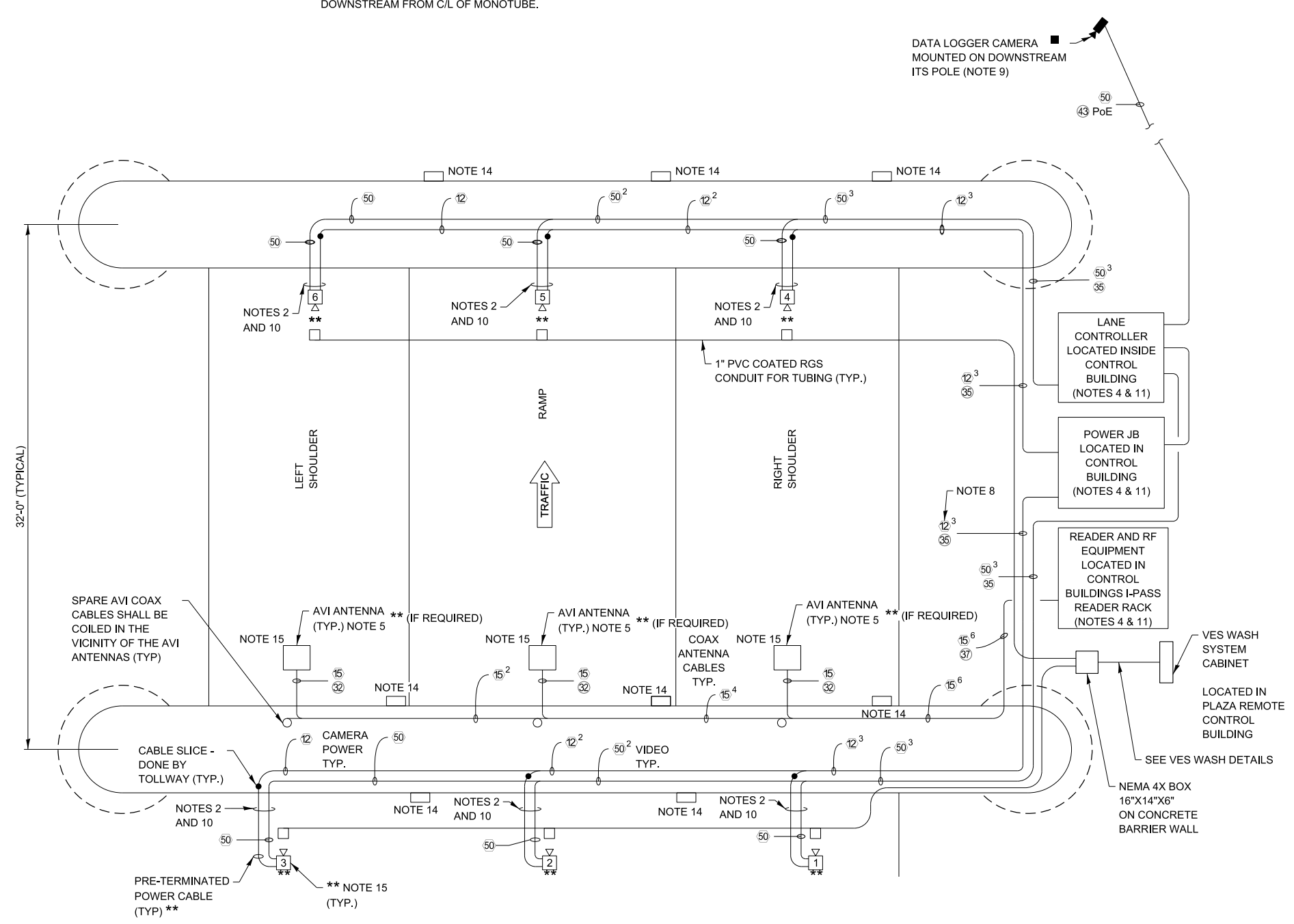
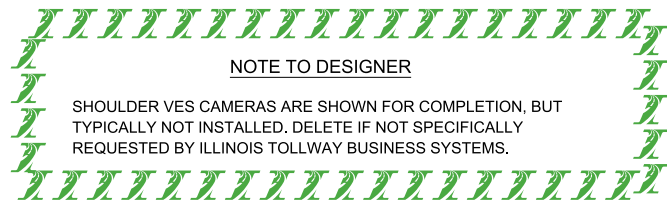
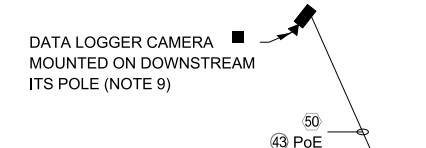

**FRONT / REAR PLATE VES BLOCK WIRING DIAGRAM**

- LEGEND:**
- \* INDICATES EQUIPMENT FURNISHED BY THE ILLINOIS TOLLWAY AND INSTALLED BY THE CONTRACTOR.
  - \*\* INDICATES EQUIPMENT FURNISHED AND INSTALLED BY THE ILLINOIS TOLLWAY.
  - INDICATES EQUIPMENT FURNISHED AND INSTALLED BY THE CONTRACTOR.

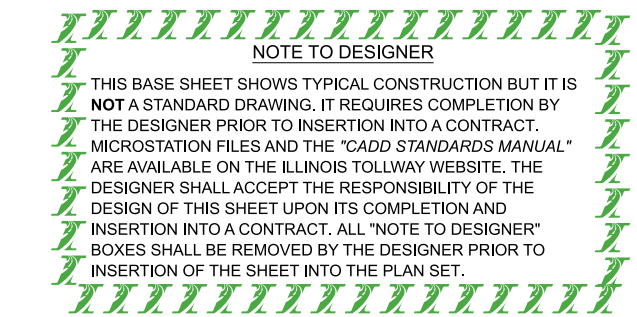

**WIRING DIAGRAM - AET 1-LANE LAYOUT**

VERSION: 2024-03      BASE SHEET: M-BUS-2519B      SHEET: 1 OF 1

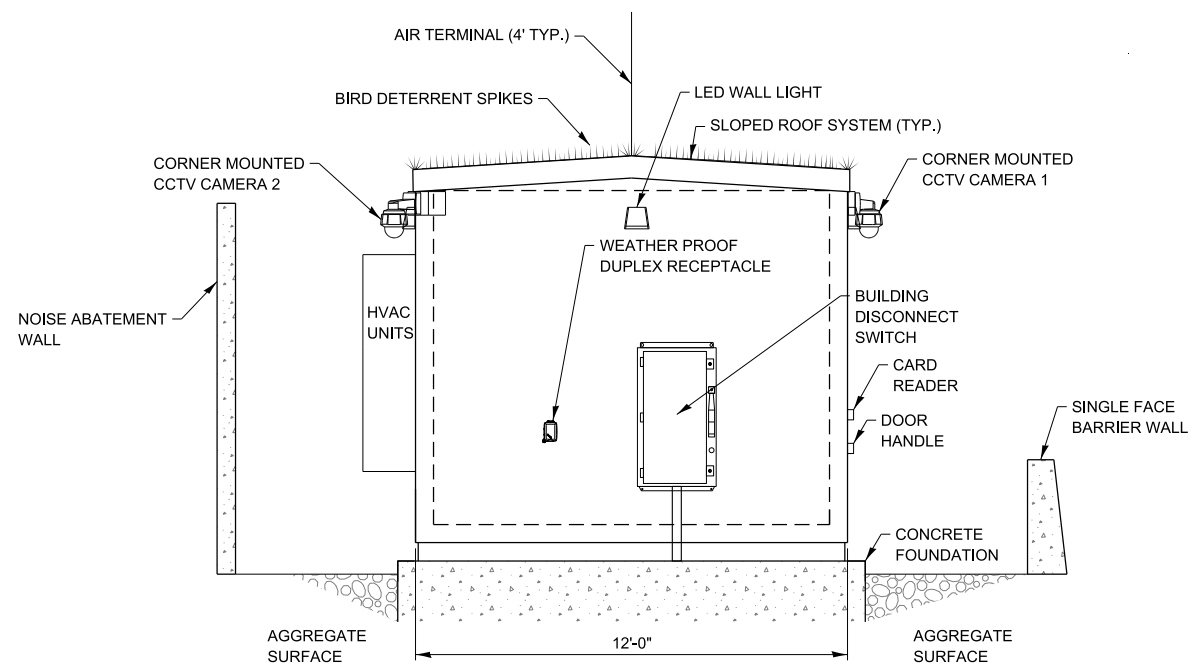

**SECTION A-A**  
NOT TO SCALE  
M-BUS-2521

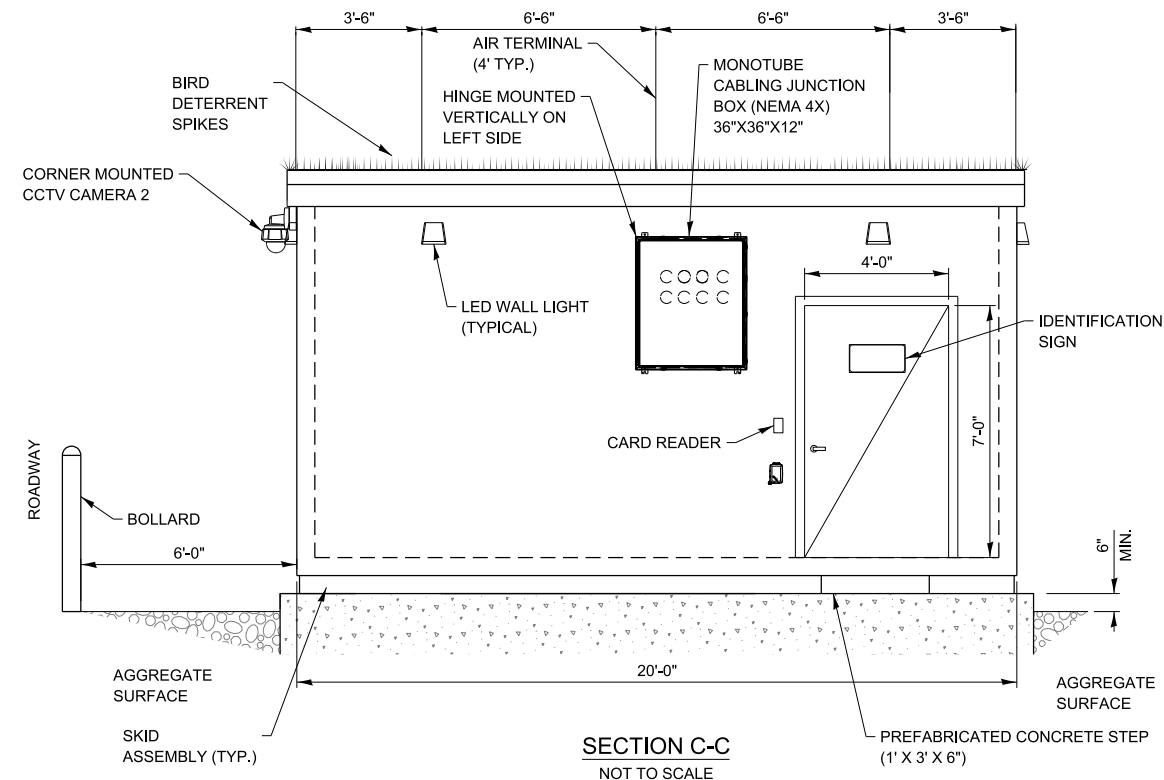

**SECTION C-C**  
NOT TO SCALE

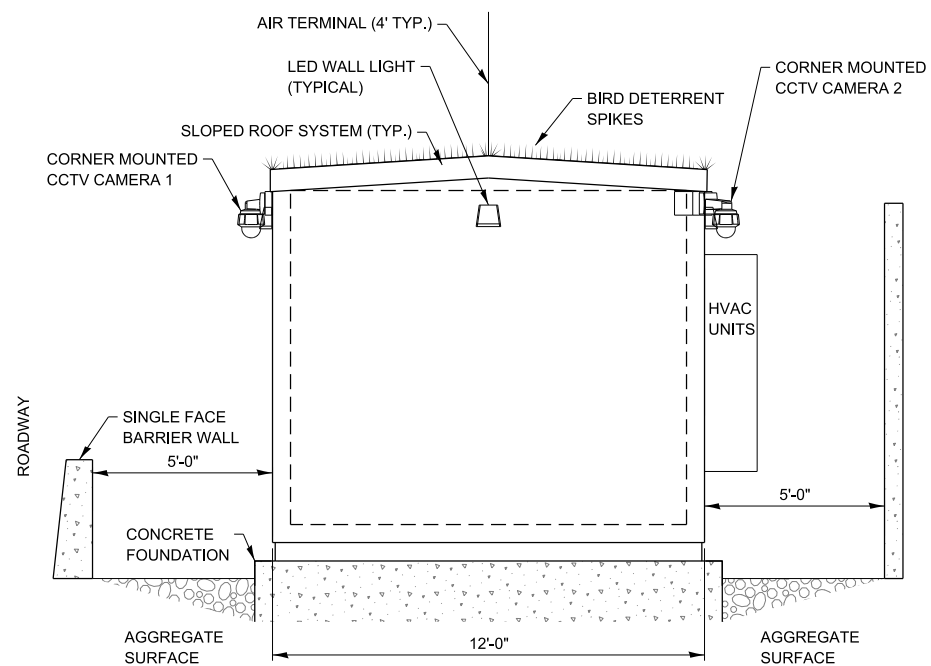

**SECTION B-B**  
NOT TO SCALE  
M-BUS-2521

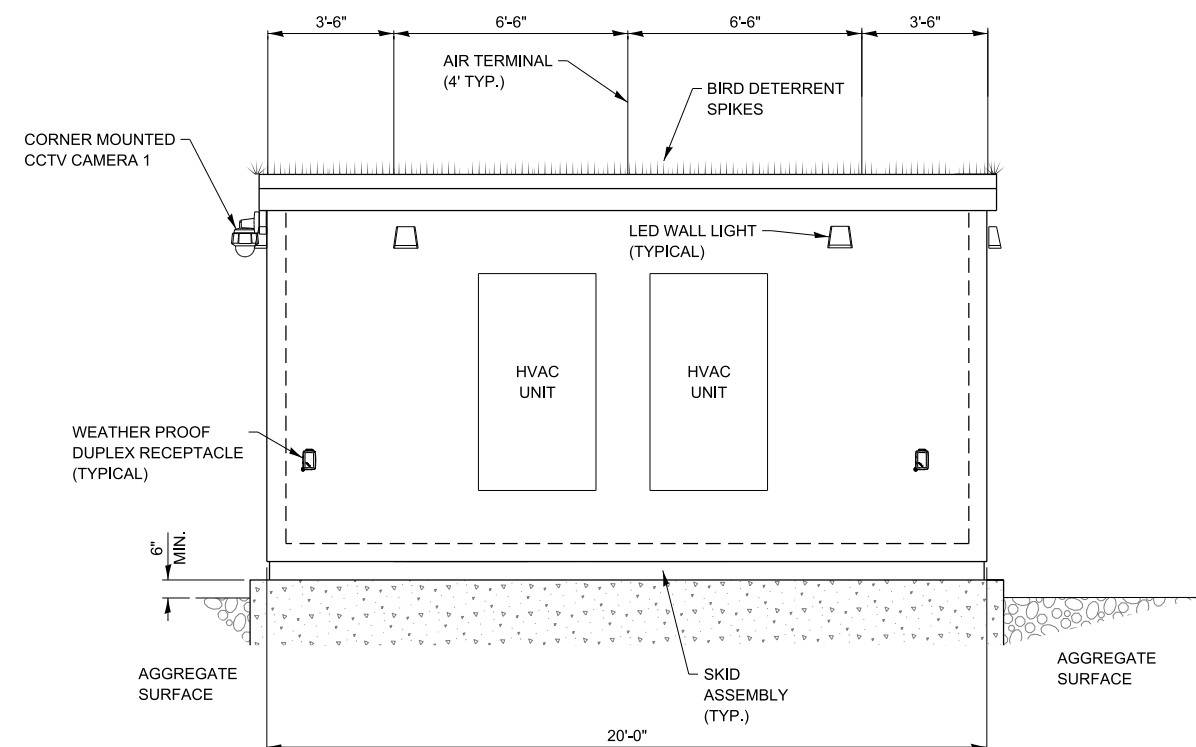

**SECTION D-D**  
NOT TO SCALE

**NOTE FOR DESIGNER:**  
AIR TERMINAL RODS ARE TO BE INSTALLED AND FIXED TO ROOF WITHOUT INTERFERING WITH THE INTEGRITY OF THE STRUCTURE.



**EXTERIOR ELEVATIONS -  
REMOTE PLAZA**

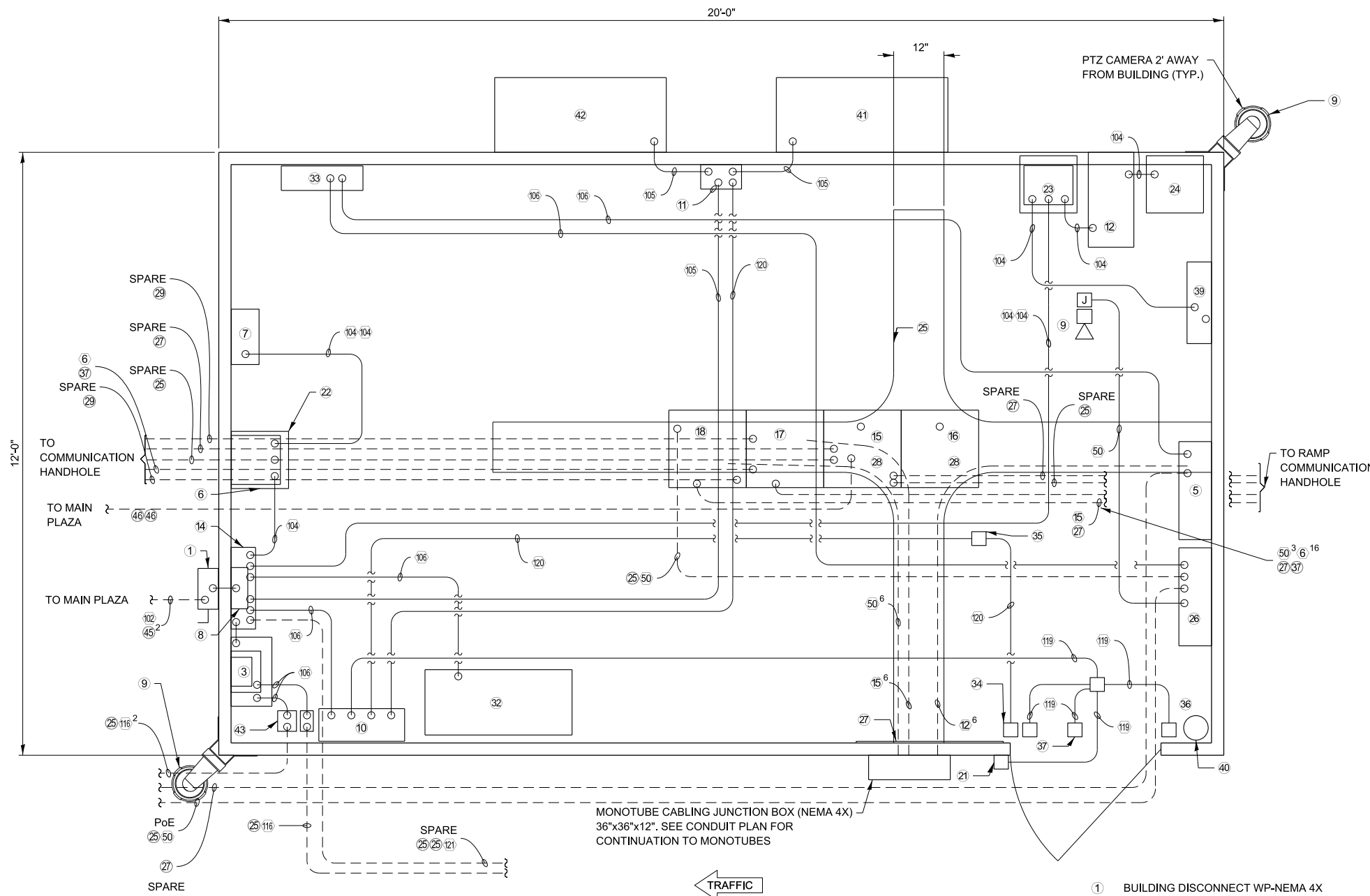

**NOTES:**

1. SEE CABLE/CONDUIT SCHEDULES SHEET FOR CABLE TAGS.
2. SEE SYSTEM POWER SINGLE LINE DIAGRAM SHEET FOR DETAILS.
3. DOOR ALARM SWITCH, SEE DETAIL ON DOOR ALARMS DETAILS SHEET.
4. PROVIDE A 3 PAIR #22 SHIELDED CABLE FOR ATS ALARMS AND ROUTE TO TSIC BOARD. ALL CONTACT CLOSURES SHALL BE ROUTED TO TSIC.
5. THE LIGHTNING PROTECTION SYSTEM DEVICE SHALL BE CONNECTED TO THE LOAD SIDE OF THE MAIN BREAKER.
6. FOR ROADWAY LIGHTING. ROUTE TO 30A. CIRCUIT BREAKER
7. ALL EXCESS (SLACK) POWER AND DATA CABLES MUST BE COILED IN THE HANDHOLE. NO EXCESS CABLES WILL BE COILED INSIDE THE CABINET.
8. NOT USED.
9. PVC SCH-80 CONDUIT INSIDE BUILDING SHALL BE USED WHEN THE CONDUIT IS EITHER COVERED OR ENCASED IN CONCRETE. TRANSITION SHALL BE ALLOWED. ANY EXPOSED CONDUIT SHALL BE PVC COATED RGS. SLEEVES SHALL BE USED WHEN DEEMED NECESSARY.
10. THE CABLE LENGTH FROM THE ANTENNA TO THE I-PASS READER SHALL NOT EXCEED 150 FEET.
11. PROVIDE A 3 PAIR #22 SHIELDED CABLE FOR SMOKE DETECTOR ALARM CONTACT AND ROUTE TO CARD READER EQUIPMENT.
12. PROVIDE AN ETHERNET CABLE FROM UPS AND FROM CARD READER PANEL TO LOCAL BACKBONE RACK. NETWORK SWITCHES TO BE PROCURED BY OTHERS.
13. TERMINATE ALARM CABLES ON TERMINAL BLOCK ON TSIC BOARD.
14. NOT USED.
15. POWER FRONT AND REAR VES CAMERAS FROM 24V DC VIDEO JUNCTION BOX #3 AND DATA LOGGER CAMERA FROM SECURITY VIDEO JUNCTION BOX #4 ALL POWER TO BE SURGE PROTECTED.
16. ALL COPPER COMMUNICATIONS AND CONTROL CABLES SHALL ENTER BUILDING ALONG OUTSIDE WALL AND BE CONNECTED TO A SURGE PROTECTION THAT IS GROUNDED TO GROUND BUS IN BUILDING.
17. LOCATION OF (6) RACKS BE IN THE MIDDLE OF THE ROOM.
18. FOR SECURITY CAMERA, CONTRACTOR TO VERIFY CLEAR UNOBSTRUCTED LINE OF SIGHT TO THE ENTRANCE DOORS.
19. INSTALL TRANSFORMER ON 6" CONCRETE PAD 1 FT AWAY FROM EXTERIOR WALL. ALL FEED TO THIS TRANSFORMER SHALL BE UNDERGROUND.
20. PROVIDE (2) 6" SDR 11 HDPE SLEEVES EACH, SEE BASE SHEET \$M-BUS-2547 FOR DETAILS SLEEVE SHALL HAVE:
  - (1) 1 1/2" CNC DUCT (SOLID GREEN)
  - (1) 1 1/2" CNC DUCT (GREEN / WHITE STRIPE)
  - (1) 1 1/2" CNC DUCT (BLACK / RED STRIPE)

**LEGEND**

1 BUILDING DISCONNECT WP-NEMA 4X	14 ELECTRICAL PANEL MDP-2	25 CABLE TRAY	35 SMOKE DETECTOR
2 NOT USED.	15 19" RACK LOCAL AND BACKBONE FIBER	26 VIDEO JB POWER #4	36 NOT USED.
3 LIGHTING TRANSFORMER, CONTRACTOR, AND CIRCUIT BREAKER	16 19" RACK ITS FIBER	27 TSIC BOARD	37 MAGNETIC LOCK
4 NOT USED.	17 19" RACK I-PASS READER REMOTE PLAZA	28 SMF DISTRIBUTION PANEL	38 NOT USED.
5 VIDEO JB POWER #3	18 19" RACK LANE CONTROL REMOTE PLAZA	29 NOT USED.	39 ITS 2-1 PANEL
6 BYPASS SWITCH	19 NOT USED.	30 NOT USED.	40 FIRE EXTINGUISHER
7 UPS-2 PANEL.	20 NOT USED.	31 NOT USED.	41 HVAC UNIT - 1
8 SPD LIGHTNING PROTECTION SYSTEM	21 CARD READER	32 VES WASH CABINET	42 HVAC UNIT - 2
9 SECURITY CAMERA	22 FREE STANDING UPS (4KVA)	33 PANEL UPS-2	43 30A/2P C/B
10 CARD READER PANEL	23 NOT USED	34 PULL STATION	
11 HVAC CONTROL PANEL	24 BYPASS SWITCH CABINET ITS POWER		
12 UPS-ITS-2 (5 KVA)			
13 5 KVA, 208V/480V OUTDOOR TYPE SINGLE PHASE TRANSFORMER, NEMA 4X			

**CONTROL BUILDING REMOTE TOLL PLAZA EQUIPMENT LAYOUT**  
NOT TO SCALE

**NOTE TO DESIGNER**  
THIS BASE SHEET SHOWS TYPICAL CONSTRUCTION BUT IT IS NOT A STANDARD DRAWING. IT REQUIRES COMPLETION BY THE DESIGNER PRIOR TO INSERTION INTO A CONTRACT. MICROSTATION FILES AND THE "CADD STANDARDS MANUAL" ARE AVAILABLE ON THE ILLINOIS TOLLWAY WEBSITE. THE DESIGNER SHALL ACCEPT THE RESPONSIBILITY OF THE DESIGN OF THIS SHEET UPON ITS COMPLETION AND INSERTION INTO A CONTRACT. ALL "NOTE TO DESIGNER" BOXES SHALL BE REMOVED BY THE DESIGNER PRIOR TO INSERTION OF THE SHEET INTO THE PLAN SET.

**NOTE TO DESIGNER**  
IF DISTANCE BETWEEN MAIN AND REMOTE PLAZA ANTENNAS IS LESS THAN 500 FT., PROVIDE CONDUIT AND SYNC CABLE TO CONNECT ANTENNA READERS IN THE MAIN AND REMOTE CONTROL BUILDINGS.



**CONTROL BUILDING EQUIPMENT LAYOUT - REMOTE PLAZA**

VERSION: 2026-03      BASE SHEET: M-BUS-2521      SHEET: 1 OF 1

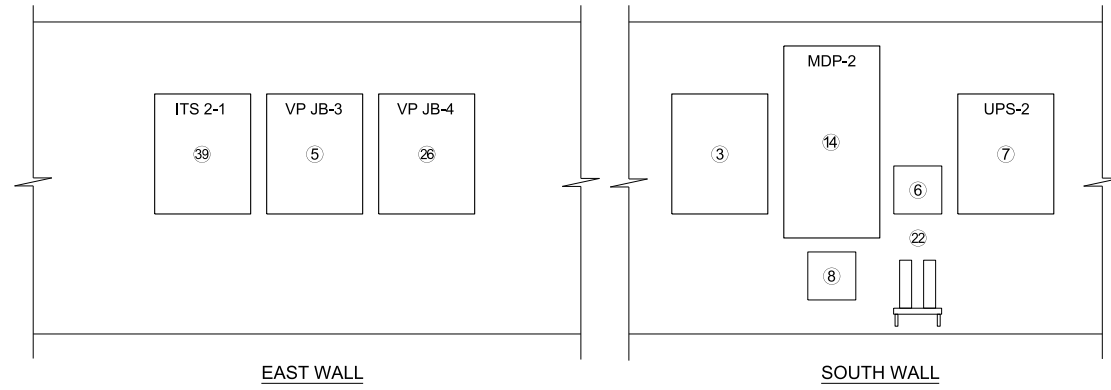

**WALL ELEVATIONS**  
NOT TO SCALE  
NOTE 2





**EQUIPMENT LEGEND**

ITEM	DESCRIPTION
③	LIGHTING CONTRACTOR 120V, 30A, 1 PHASE, 4-POLE IN A NEMA 1 ENCLOSURE WITH A THREE POSITION SELECTOR SWITCH HAND-OFF-AUTO MOUNTED ON THE COVER. TRANSFORMER DRY TYPE, 2KVA, 120V PRIMARY, 480V SECONDARY, 1-PHASE, 3-WIRE ROADWAY LIGHTING.
⑤	VIDEO JB POWER #3
⑥	BYPASS SWITCH
⑦	UPS-2 PANEL.
⑧	LIGHTNING ARRESTOR SYSTEM
⑭	MAIN DISTRIBUTION PANEL (MDP-2), 208Y/120V, 3 PHASE, 4W 100 AMP, MAIN CIRCUIT BREAKER
⑳	FREE STANDING UPS (4KVA)
㉔	VIDEO JB POWER #4
㉙	ITS 2-1 PANEL

**NOTES:**

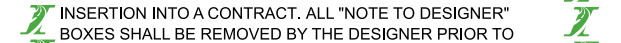
- CONTRACTOR SHALL ROUTE ALL CONDUIT AS REQUIRED TO ALL PANELS, EQUIPMENT AND CONTROL DEVICES.
- THE WALL ELEVATIONS FOR THE MAIN RAMP CONTROL BUILDING ARE SHOWN ON THIS DRAWING. THE WALL ELEVATIONS (NOT SHOWN) FOR THE REMOTE RAMP CONTROL BUILDING ARE SIMILAR.
- MINIMUM CLEARANCE BETWEEN CABINETS SHALL ALLOW THE DOORS TO OPEN 90 DEGREES MINIMUM.

  
**NOTE TO DESIGNER**  

 THIS BASE SHEET SHOWS TYPICAL CONSTRUCTION BUT IT IS  **NOT** A STANDARD DRAWING. IT REQUIRES COMPLETION BY  THE DESIGNER PRIOR TO INSERTION INTO A CONTRACT.  MICROSTATION FILES AND THE "CADD STANDARDS MANUAL"  ARE AVAILABLE ON THE ILLINOIS TOLLWAY WEBSITE. THE  DESIGNER SHALL ACCEPT THE RESPONSIBILITY OF THE  DESIGN OF THIS SHEET UPON ITS COMPLETION AND  INSERTION INTO A CONTRACT. ALL "NOTE TO DESIGNER"  BOXES SHALL BE REMOVED BY THE DESIGNER PRIOR TO  INSERTION OF THE SHEET INTO THE PLAN SET.   



**INTERIOR ELEVATIONS -  
REMOTE PLAZA**

VERSION: 2026-03	BASE SHEET: M-BUS-2522	SHEET: 1 OF 1
---------------------	---------------------------	------------------

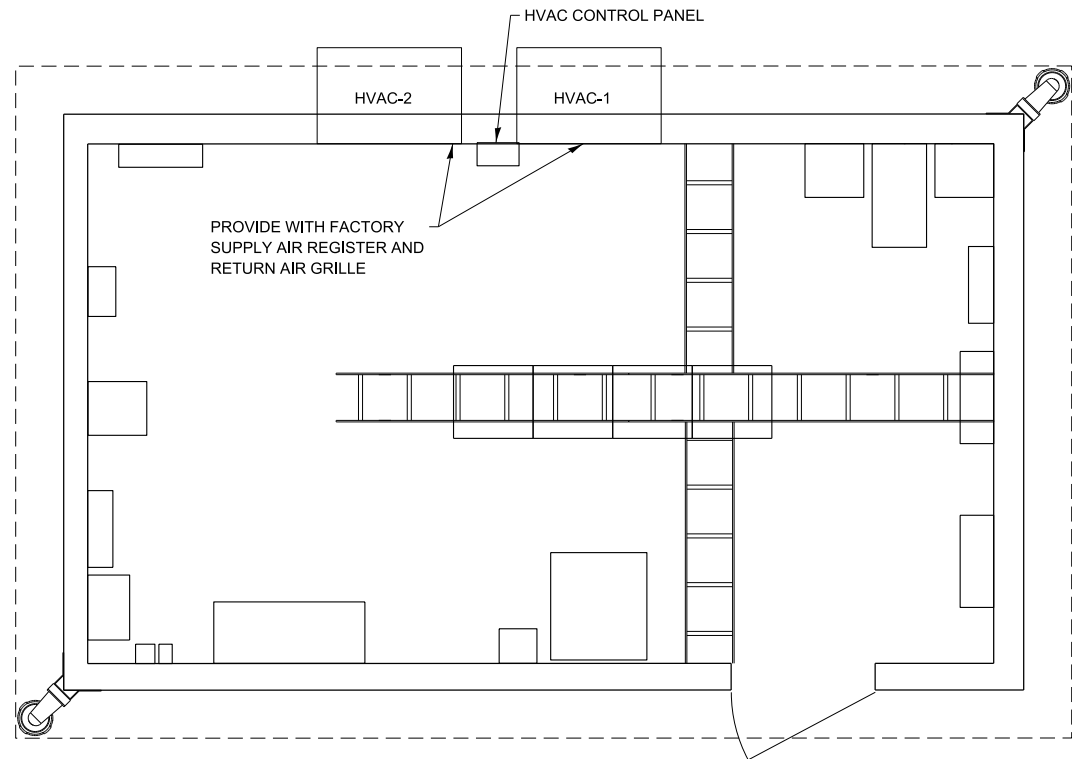

BUILDING MECHANICAL PLAN

NOTES:

1. UNIT SHALL HAVE ARI CERTIFIED COILS, AIWCA RATED FANS, AND UL LISTED & LABELED ELECTRICAL COMPONENTS.
2. PROVIDE HVAC UNITS WITH FACTORY SUPPLY AND RETURN GRILLES.
3. HVAC PROVIDE LEAD/LAG THERMOSTAT CONTROLLER BARD MODEL #MC4001-AC WITH BASE ALARMS AND ETHERNET ACCESS.
4. ALL MANUFACTURERS AND PART NUMBERS ARE FOR REFERENCE. THE CONTRACTOR SHALL PROVIDE CALCULATIONS FOR HVAC AND HEATING SYSTEM BASED ON BUILDING CONSTRUCTION AND INTERNAL BUILDING LOADS.

NOTE TO DESIGNER  
 THE ESTIMATED EQUIPMENT BUILDING LOADS FOR EQUIPMENT IS 19,000 BTU/HR. THE DESIGNER SHALL SIZE THE HVAC SYSTEMS ACCORDINGLY.

NOTE TO DESIGNER  
 THIS BASE SHEET SHOWS TYPICAL CONSTRUCTION BUT IT IS NOT A STANDARD DRAWING. IT REQUIRES COMPLETION BY THE DESIGNER PRIOR TO INSERTION INTO A CONTRACT. MICROSTATION FILES AND THE "CADD STANDARDS MANUAL" ARE AVAILABLE ON THE ILLINOIS TOLLWAY WEBSITE. THE DESIGNER SHALL ACCEPT THE RESPONSIBILITY OF THE DESIGN OF THIS SHEET UPON ITS COMPLETION AND INSERTION INTO A CONTRACT. ALL "NOTE TO DESIGNER" BOXES SHALL BE REMOVED BY THE DESIGNER PRIOR TO INSERTION OF THE SHEET INTO THE PLAN SET.

ELECTRICAL ROOM																						
MARK	LOCATION	SERVES	NOM. TON	TOTAL AIRFLOW CFM	OUTSIDE AIRFLOW CFM	ESP (IN WG)	REFRIG. TYPE	COOLING DATA						HEATING DATA				ELECTRICAL DATA			MANUFACTURER/ MODEL NUMBER	REMARKS
								TOTAL CAP MBH	SENS CAP MBH	EAT (DEG F) DB	EAT (DEG F) WB	OUTDOOR TEMP (DEG F)	MIN. EER AT ARI CONDITIONS	CAP MBH	EAT (DEG F) DB	OUTDOOR TEMP (DEG F)	SUPPLEMENTAL HEATING (KW)	VOLTS	PH	HZ		
HVAC-01	OUTSIDE	BUILDING	4	1500	-	0.15	R454B A2L	45.5	34.0	75	62	90	11	17.1	70	0	5	208/240	1	60	BARD W5SAF0A05ZPXXXJ	
HVAC-02	OUTSIDE	BUILDING	4	1500	-	0.15	R454B A2L	45.5	34.0	75	62	90	11	17.1	70	0	5	208/240	1	60	BARD W5SAF0A05ZPXXXJ	

ABBREVIATION LEGEND  
 CFM - CUBIC FEET PER MINUTE



MECHANICAL PLAN - REMOTE PLAZA

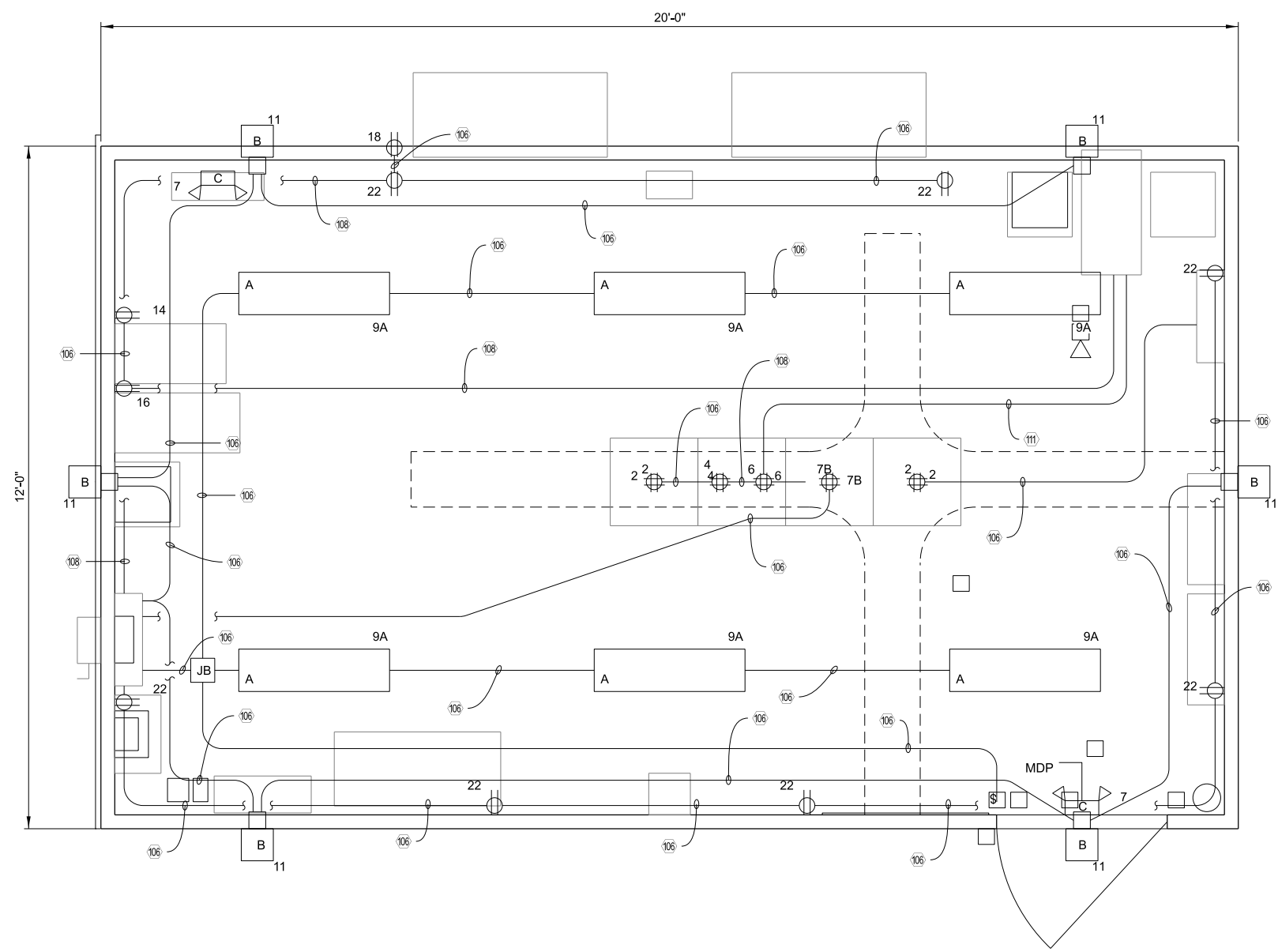

REMOTE TOLL PLAZA - BUILDING LIGHTING AND RECEPTACLE PLAN  
NOT TO SCALE

**NOTES:**

1. SEE CABLE/CONDUIT SCHEDULES SHEET FOR CABLE TAGS.
2. RECEPTACLE AND LIGHTING CONDUIT SHALL BE 3/4" WITH 2-1/C #12 AND 1/C #12 GRD, UNLESS OTHERWISE NOTED.
3. FOR PANEL SCHEDULES, SEE PANELBOARD SCHEDULES SHEET.
4. PROVIDE CONNECTION TO RECEPTACLES FOR THE EQUIPMENT RACKS AS SPECIFIED. THE PLUG STRIP SHALL BE MOUNTED TO THE SIDE OF THE CABINET AS DIRECTED BY THE ENGINEER.
5. FOR LIGHTING FIXTURE SCHEDULE, ELECTRICAL SYMBOLS, LEGEND, AND ABBREVIATIONS, SEE LEGEND SHEET.
6. LIGHTING AND RECEPTACLES SHALL BE FED FROM PANEL MDP-2.
7. CONNECT EMERGENCY BATTERY PACK AHEAD OF LIGHT CIRCUIT.
8. COMMUNICATION AND EQUIPMENT RACKS SHALL BE APPROVED BY THE ENGINEER. A SAMPLE IS SHOWN BELOW.  
SAMPLE:  
I-PASS READER  
LANE CONTROL  
ITS FIBER  
LOCAL AND BACKBONE FIBER
9. CONTRACTOR SHALL COORDINATE FINAL RACK LAYOUT WITH THE ENGINEER AND THE ILLINOIS TOLLWAY.
10. NETWORK SWITCHES PROCURED BY OTHERS.

**NOTE TO DESIGNER**

THIS BASE SHEET SHOWS TYPICAL CONSTRUCTION BUT IT IS NOT A STANDARD DRAWING. IT REQUIRES COMPLETION BY THE DESIGNER PRIOR TO INSERTION INTO A CONTRACT. MICROSTATION FILES AND THE "CADD STANDARDS MANUAL" ARE AVAILABLE ON THE ILLINOIS TOLLWAY WEBSITE. THE DESIGNER SHALL ACCEPT THE RESPONSIBILITY OF THE DESIGN OF THIS SHEET UPON ITS COMPLETION AND INSERTION INTO A CONTRACT. ALL "NOTE TO DESIGNER" BOXES SHALL BE REMOVED BY THE DESIGNER PRIOR TO INSERTION OF THE SHEET INTO THE PLAN SET.

**LEGEND:**

- ① FIBER-OPTIC CORNING RACK INTERCONNECT CENTER CCH-04U (4 RU)
- ② FIBER-OPTIC CORNING RACK INTERCONNECT CENTER CCH-04U (4 RU)
- ③ FUTURE NETWORK SWITCHES - (1 RU) NOTE 10
- ④ FUTURE NETWORK SWITCHES - (1 RU) NOTE 10
- ⑤ COMMSCOPE MODULAR PATCH PANEL - (2 RU)

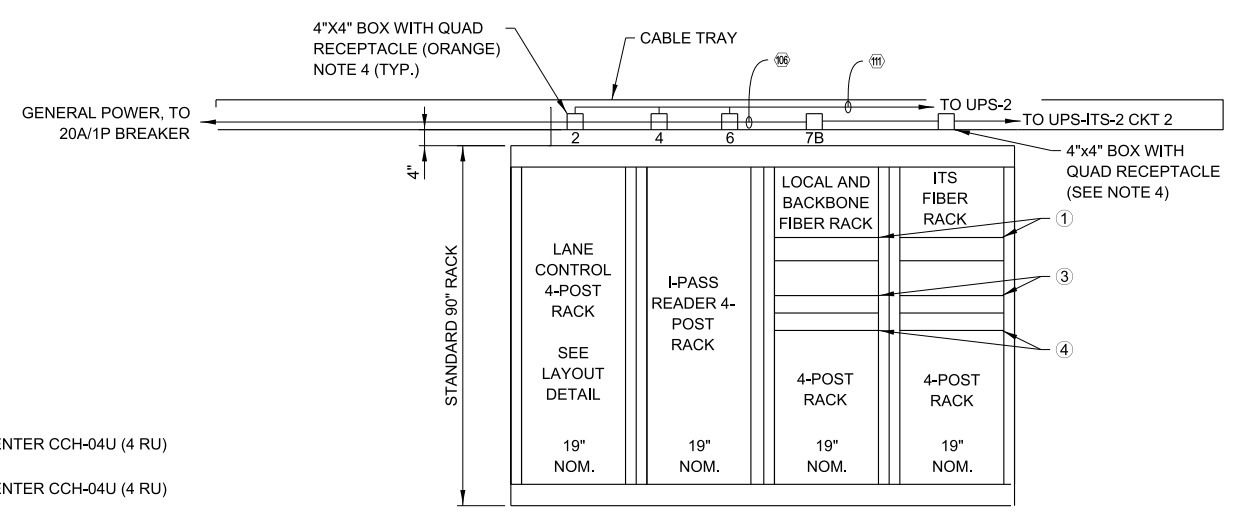

COMMUNICATIONS AND EQUIPMENT RACK ELEVATION  
NOT TO SCALE

**CONTROL BUILDING LIGHTING AND RECEPTACLE PLAN - REMOTE PLAZA**

VERSION: 2021-03      BASE SHEET: M-BUS-2524      SHEET: 1 OF 1

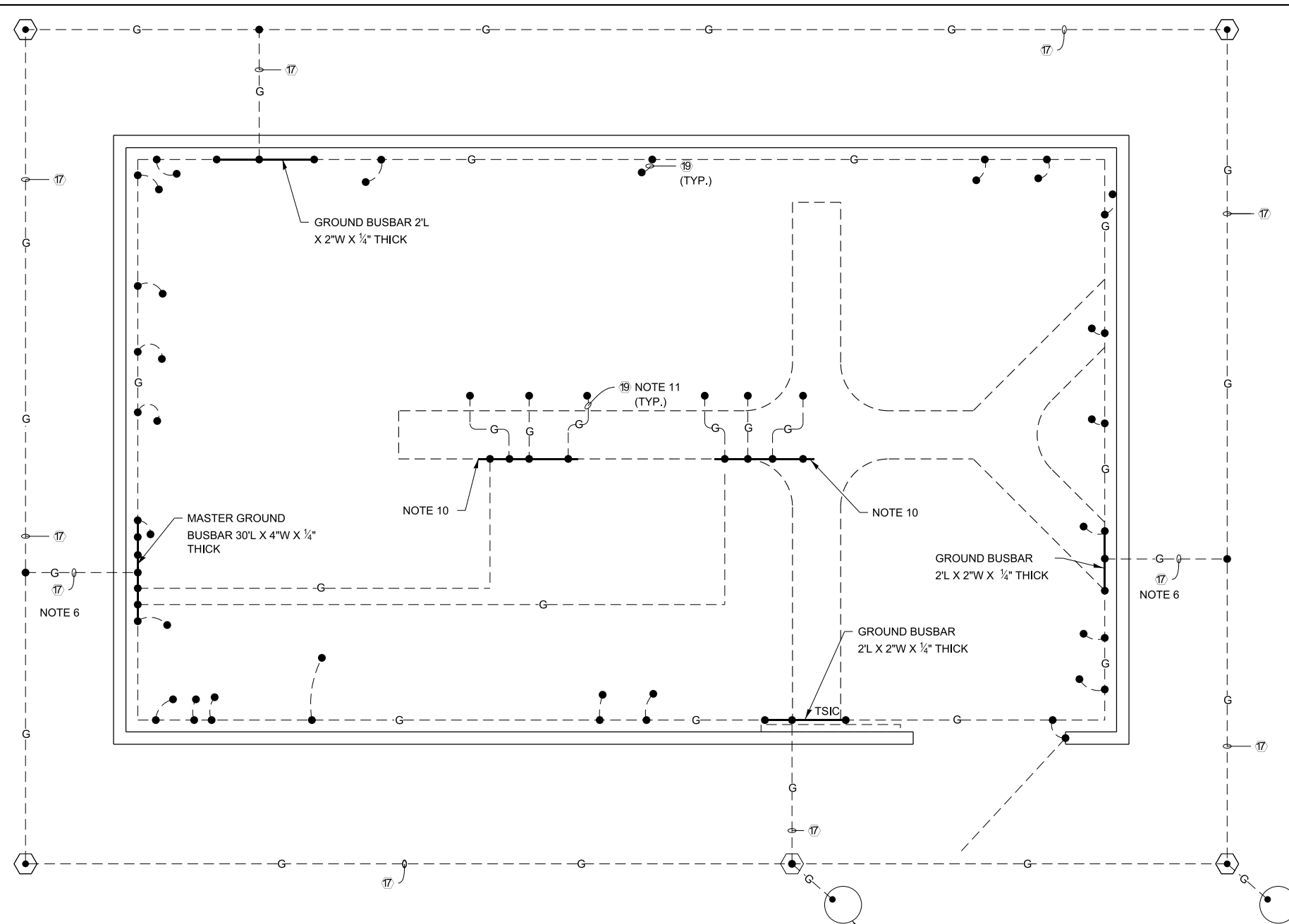

**BUILDING ELECTRICAL GROUNDING LAYOUT**  
NOT TO SCALE

- NOTES:**
- SEE CABLE/CONDUIT SCHEDULE FOR CABLE TAGS.
  - SEE CONTROL BUILDING EQUIPMENT LAYOUT SHEET FOR MORE DETAIL.
  - DETAIL SHOWS INSTALLATION IN UNPAVED AREA. WHEN INSTALLING IN A PAVED AREA, INCORPORATE GROUND WELL IN THE POUR.
  - GROUND WELLS ARE REQUIRED AT EVERY GROUND ROD.
  - NOT USED
  - PROVIDE 1" PVC CONDUIT FOR GROUND CABLES UNDER BUILDING (TYP.).
  - ALL COPPER GROUND BARS SHALL BE OF HARD DRAWN, COMMERCIALY PURE, ELECTROLYTIC COPPER, FOR USE AS AN ELECTRICAL CONDUCTOR AND SHALL COMPLY WITH ASTM SPEC. B-187 OF LATEST DATE.
  - BOLTS, NUTS, & WASHERS USED FOR CONNECTION TO GROUND BUSBARS SHALL BE SOLID COPPER.
  - WELD PER MANUFACTURER SPECIFICATION (ERICO PRODUCTS OR BURNDY CORP.).
  - THE COPPER GROUND BUSBAR SHALL BE MOUNTED TO THE CABLE TRAY ABOVE EQUIPMENT RACKS.
  - PROVIDE A #2 AWG GROUND CABLE FROM THE FRAME OF EACH EQUIPMENT RACK TO THE GROUND BUS AS SHOWN. THE CABLE SHALL BE BOLTED TO THE RACK USING A SEAMLESS HEAVY DUTY COMPRESSION TERMINAL.
  - A FOUR INCH GAP SHALL BE PROVIDED BETWEEN THE ENDS OF THE TWO CONDUCTORS THAT MAKE UP THE INTERNAL PERIMETER GROUND BUS CONDUCTOR.
  - ALL EQUIPMENT LOCATED INSIDE THE BUILDING SHALL BE BONDED TO THE MAIN GROUND BUS OR THE INTERNAL PERIMETER GROUND CONDUCTOR WITH A #2 AWG GROUND CABLE. ALL CONNECTIONS MUST BE EXOTHERMICALLY WELDED.
  - THE INTERNAL PERIMETER GROUND BUS CONDUCTOR MUST BE INSTALLED HORIZONTALLY ALONG THE WALL APPROXIMATELY 7'-6" ABOVE FINISHED FLOOR. THE CONDUCTOR SHALL BE SUPPORTED 2 INCHES FROM THE WALL SURFACE ON INSULATED STANDOFFS. THE STANDOFFS SHALL BE INSTALLED AT INTERVALS AS NECESSARY TO KEEP THE CONDUCTOR SECURELY IN PLACE WITHOUT NOTICEABLE SAGS AND BENDS.
  - THE GROUND BUSBARS MUST BE MOUNTED APPROXIMATELY 7'-6" ABOVE FINISHED FLOOR AND MOUNTED TO WALL USING A MOUNTING BRACKET WITH INSULATOR.

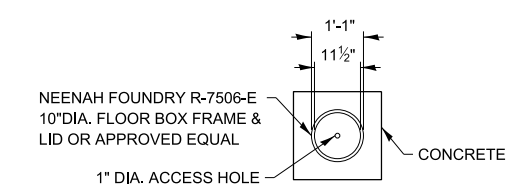

**GROUND WELL PLAN DETAIL**  
NOT TO SCALE (NOTE 3)

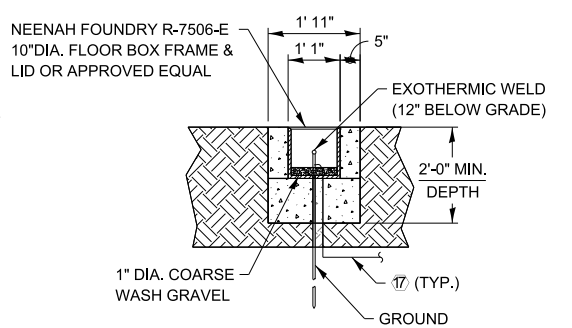

**GROUND WELL ELEVATION DETAIL**  
NOT TO SCALE (NOTE 3)

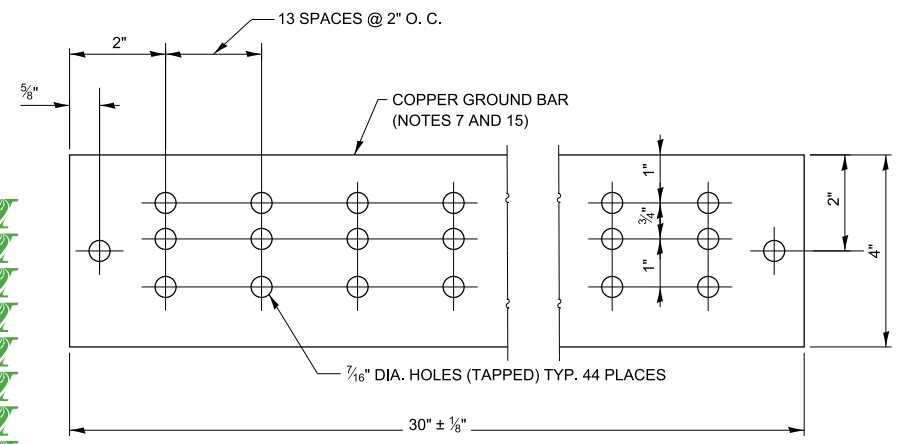

**MASTER GROUND BUSBAR SUPPORT SPACING DETAIL**  
NOT TO SCALE

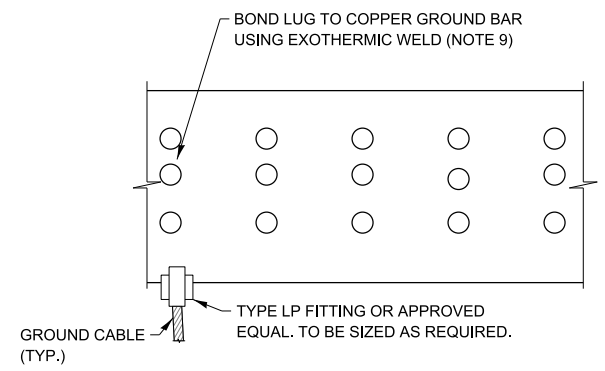

**MASTER GROUND BUSBAR CONNECTION DETAIL**  
NOT TO SCALE

**NOTE TO DESIGNER**

THIS BASE SHEET SHOWS TYPICAL CONSTRUCTION BUT IT IS NOT A STANDARD DRAWING. IT REQUIRES COMPLETION BY THE DESIGNER PRIOR TO INSERTION INTO A CONTRACT. MICROSTATION FILES AND THE "CADD STANDARDS MANUAL" ARE AVAILABLE ON THE ILLINOIS TOLLWAY WEBSITE. THE DESIGNER SHALL ACCEPT THE RESPONSIBILITY OF THE DESIGN OF THIS SHEET UPON ITS COMPLETION AND INSERTION INTO A CONTRACT. ALL "NOTE TO DESIGNER" BOXES SHALL BE REMOVED BY THE DESIGNER PRIOR TO INSERTION OF THE SHEET INTO THE PLAN SET.

**CONTROL BUILDING GROUNDING DETAILS - REMOTE PLAZA**

VERSION: 2021-03      BASE SHEET: M-BUS-2525      SHEET: 1 OF 1

PANELBOARD <u>MDP-2</u>				MAINS <u>100A. MCB</u>								
VOLTAGE <u>120/208V</u>				BUS RATING <u>100A.</u>								
PHASE/WIRE <u>3/4</u>				MOUNTING <u>SURFACE</u>								
DESCRIPTION	CKT NO.	LOAD (WATTS)			AMPS/ POLES	CKT BKR	AMPS/ POLES	LOAD (WATTS)			CKT NO.	DESCRIPTION
		A	B	C				A	B	C		
SPARE	1	--			20/1		20/1	--			2	SPARE
SPARE	3		-		20/1		20/1		200		4	LIGHTING CONTRACTOR (CONTROL)
SPARE	5			--	20/1		50A/2P			3600	6	HVAC 1
EMERGENCY LIGHT	7	100			20/1		50A/2P		3600		8	HVAC 2
INTERIOR LIGHTS	9		200		20/1		50A/2P			3600	10	HVAC 2
EXTERIOR BUILDING LIGHTS	11			240	20/1		30/1			--	12	SPARE
VES WASH SYSTEM (LOC 2)	13	2500			30/1		30/2	2500			14	UPS-2 (5 KVA)
SPARE	15		-		20/1		20/1		2500		16	SPARE
SPARE	17			--	20/1		20/1			--	18	SPARE
EXTERIOR RECEPTACLE	19	200			20/1		20/1	400			20	INTERIOR RECEPTACLES
EXTERIOR RECEPTACLE	21		200		20/1		20/1		400		22	INTERIOR RECEPTACLES
SPARE	23			-	20/1		50A/2P			2500	24	UPS-2 (TOLLING & ITS)
SPARE	25				30/2		20/1		--		26	SPARE
SPARE	27				30/2		30/2				28	SPARE
SPARE	29			--	30/1		30/2				30	SPARE
SPARE	31	-			20/1		20/1				32	SPARE
ROADWAY LTG TRANSFORMER	33		960		20/2		20/1		--		34	SPARE
ROADWAY LTG TRANSFORMER	35			960	20/2		40/1				36	SPARE
"A"		2800						9000				"A"
"B"			1360						6700			"B"
"C"				1200						9700		"C"
TOTAL WATTS "A,B,C"												= 30760 KW

PANELBOARD <u>UPS-2</u>				MAINS <u>30A. 2P. MCB</u>										
VOLTAGE <u>120V./208V.</u>				BUS RATING <u>60A.</u>										
PHASE/WIRE <u>1/3</u>				MOUNTING <u>SURFACE</u>										
DESCRIPTION	CKT NO.	LOAD (WATTS)			AMPS/ POLES	CKT BKR	CKT BKR	AMPS/ POLES	LOAD (WATTS)			CKT NO.	DESCRIPTION	
		A	B	C					A	B	C			
SPARE	1	--			20/1		20/1		300			2	RACK RECEPTACLE (LCC) RAMP L1	
SPARE	3		-		20/1		20/1		300			4	RACK RECEPTACLE (I-PASS) RAMP L1	
VIDEO POWER JUNCTION BOX 3	5	400			20/1		20/1		400			6	RACK RECEPTACLE (FIBER)	
VIDEO POWER JUNCTION BOX 4	7	400			20/1		20/1		200			8	CARD READER PANEL	
SPARE	9			-	20/1		20/1					10	SPARE	
SPARE	11			-	20/1		20/1					12	SPARE	
SUBTOTAL "A"									800				1200	
TOTAL WATTS "A,B,C"														= 2.0 KW

PANELBOARD <u>ITS 2</u>				MAINS <u>30A. 2P. MCB</u>										
VOLTAGE <u>120V / 208V</u>				BUS RATING <u>60A.</u>										
PHASE/WIRE <u>1/3</u>				MOUNTING <u>SURFACE</u>										
DESCRIPTION	CKT NO.	LOAD (WATTS)			AMPS/ POLES	CKT BKR	CKT BKR	AMPS/ POLES	LOAD (WATTS)			CKT NO.	DESCRIPTION	
		A	B	C					A	B	C			
SPARE	1	--			30/2P		10/1P		200			2	ITS RACK RECEPTACLES	
SPARE	3				30/2P		10/1P		--			4	SPARE	
SPARE	5			-	10/1P		10/1P		--			6	SPARE	
SPARE	7			-	10/1P		10/1P		--			8	SPARE	
SUBTOTAL = --													200	
TOTAL WATTS "A,B"														= 0.2 KW

**NOTE TO DESIGNER**

THIS BASE SHEET SHOWS TYPICAL CONSTRUCTION BUT IT IS NOT A STANDARD DRAWING. IT REQUIRES COMPLETION BY THE DESIGNER PRIOR TO INSERTION INTO A CONTRACT. MICROSTATION FILES AND THE "CADD STANDARDS MANUAL" ARE AVAILABLE ON THE ILLINOIS TOLLWAY WEBSITE. THE DESIGNER SHALL ACCEPT THE RESPONSIBILITY OF THE DESIGN OF THIS SHEET UPON ITS COMPLETION AND INSERTION INTO A CONTRACT. ALL "NOTE TO DESIGNER" BOXES SHALL BE REMOVED BY THE DESIGNER PRIOR TO INSERTION OF THE SHEET INTO THE PLAN SET.

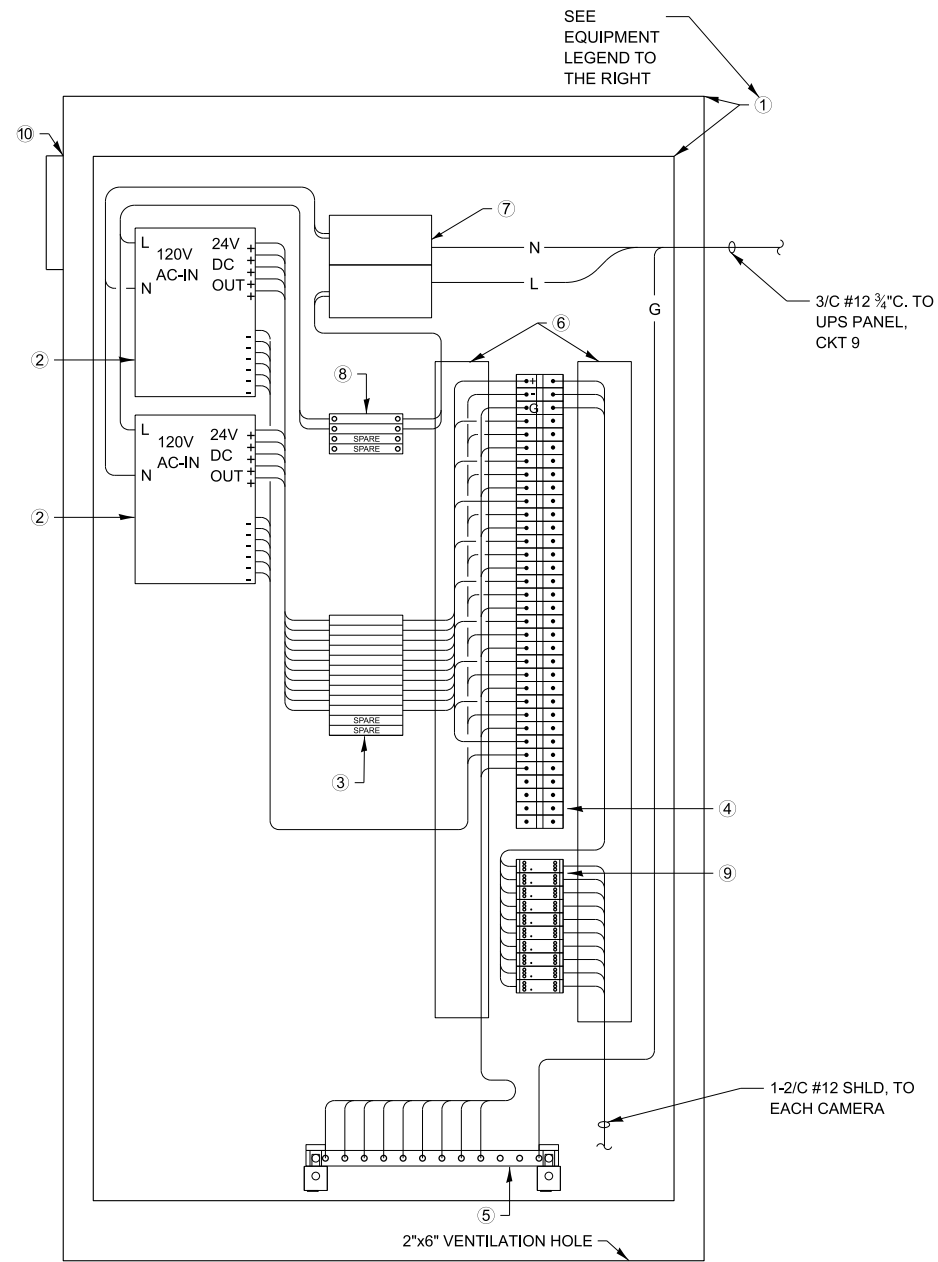

FRONT & REAR VES CAMERA  
VIDEO POWER JUNCTION BOX - REMOTE PLAZA  
ALTERNATIVE LAYOUT  
NOT TO SCALE

**EQUIPMENT LEGEND -  
VIDEO POWER JUNCTION BOX  
(ALTERNATIVE LAYOUT)**

ITEM	QUANTITY (SAMPLE)	DESCRIPTION
①	1	48"H X 24"W X 8"D NEMA 1 ENCLOSURE WITH 44"H X 22 1/2"W BACK PANEL, HOFFMAN CATALOG NO. A-482408LE, WITH WHITE PANEL.
②	2	POWER SUPPLY 24VDC, TDK-LAMBDA NO. QM7FSDL 24/24DMS 24/24DMS 24/24DMS 24/24DMS.
③	12	TERMINAL BLOCKS, FUSE SWITCH TYPE WITH BLOWN FUSE INDICATOR COMPLETE WITH 5 AMP FUSE, MOUNTING RAIL, ANCHORS, BARRIERS, MARKING STRIPS AND JUMPERS, ALLEN BRADLEY CATALOG NO. 1492-FB1M30-D1.
④	21	TERMINAL BLOCKS, ON POLE PANEL MOUNT BLOCK SCREW TERMINAL WITH WIRE CLAMP, ALLEN BRADLEY CATALOG NO. 1492-CD6.
⑤	1	GROUND BAR SYSTEM WITH INSULATED MOUNTING BRACKET, HOFFMAN CATALOG NO. PGS2K.
⑥	LOT	PANDUIT PLASTIC WIRING DUCT SNAP-IN SLOT DESIGN AND NON-SLIP COVER, 1"W X 1"H, CATALOG NO. F1X1LG6 WITH COVER C1LG6.
⑦	1	POWER DISTRIBUTION BLOCK MARATHON NO. 1322580.
⑧	4	SQUARE D, QOU 115 1P/15A BREAKER.
⑨	10	SURGE SUPPRESSOR MTL MODEL ZB24580.
⑩	1	SQUARE AXIAL FAN 4 1/16" X 4 1/16", 1 1/2" IN DEPTH, 115 CFM, IP20, CAST ALUMINUM FRAME, 115V AC, AND COMPACT AXIAL FAN GUARD 4 1/16" X 4 1/16".

**EQUIPMENT LEGEND -  
VIDEO POWER JUNCTION BOX**

ITEM	QUANTITY	DESCRIPTION
①	1	48"H X 24"W X 8"D NEMA 1 ENCLOSURE WITH 44"H X 22 1#2"W BACK PANEL, HOFFMAN CATALOG NO. A-482408LE, WITH WHITE PANEL.
②	4	POWER SUPPLY 24VDC, MEANWELL MODEL NO. SDR-240-24
③	24	TERMINAL BLOCKS, FUSE SWITCH TYPE WITH BLOWN FUSE INDICATOR COMPLETE WITH 5 AMP FUSE, MOUNTING RAIL, ANCHORS, BARRIERS, MARKING STRIPS AND JUMPERS, ALLEN BRADLEY CATALOG NO. 1492-FB1M30-D1.
④	42	TERMINAL BLOCKS, ON POLE PANEL MOUNT BLOCK SCREW TERMINAL WITH WIRE CLAMP, ALLEN BRADLEY CATALOG NO. 1492-CD6.
⑤	1	GROUND BAR SYSTEM WITH INSULATED MOUNTING BRACKET, HOFFMAN CATALOG NO. PGS2K.
⑥	LOT	PANDUIT PLASTIC WIRING DUCT SNAP-IN SLOT DESIGN AND NON-SLIP COVER, 1"W X 1"H, CATALOG NO. F1X1LG6 WITH COVER C1LG6.
⑦	1	POWER DISTRIBUTION BLOCK MARATHON NO. 1322580.
⑧	4	SQUARE D, QOU 115 1P/15A BREAKER.
⑨	20	SURGE SUPPRESSOR MTL MODEL ZB24580.
⑩	1	SQUARE AXIAL FAN 4 1/16" X 4 1/16", 1 1/2" IN DEPTH, 115 CFM, IP20, CAST ALUMINUM FRAME, 115V AC, AND COMPACT AXIAL FAN GUARD 4 1/16" X 4 1/16".

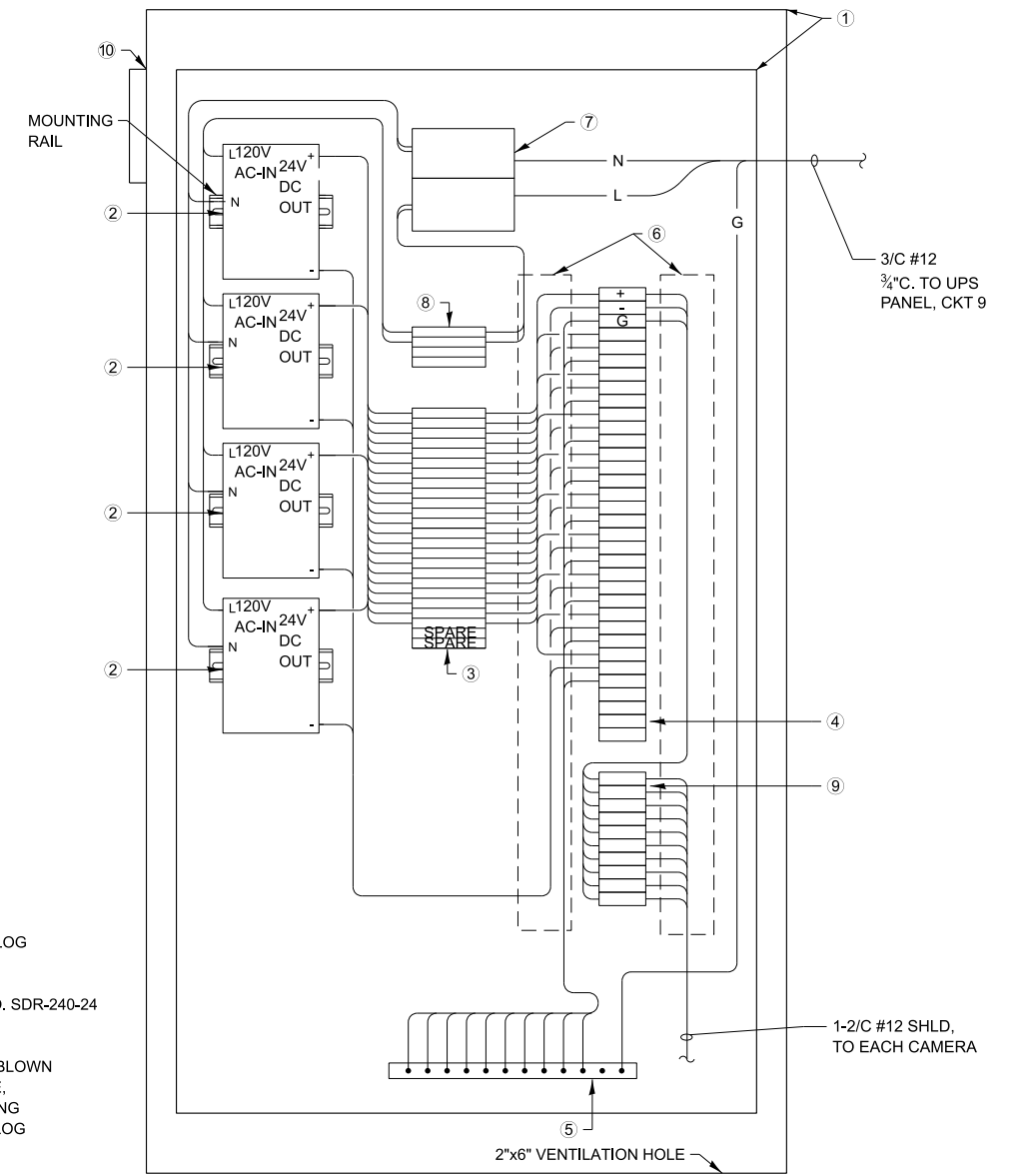

FRONT & REAR VES CAMERA  
VIDEO POWER JUNCTION BOX  
N.T.S.  
VIDEO POWER JUNCTION BOX REMOTE PLAZA

**NOTES TO DESIGNER**

- THIS BASE SHEET SHOWS TYPICAL NEW CONSTRUCTION BUT IT IS NOT A STANDARD DRAWING. IT REQUIRES COMPLETION BY THE DESIGNER PRIOR TO INSERTION INTO A CONTRACT. MICROSTATION FILES AND THE "CADD STANDARDS MANUAL" ARE AVAILABLE ON THE ILLINOIS TOLLWAY WEBSITE. THE DESIGNER SHALL ACCEPT THE RESPONSIBILITY OF THE DESIGN OF THIS SHEET UPON ITS COMPLETION AND INSERTION INTO A CONTRACT. ALL "NOTE TO DESIGNER" BOXES SHALL BE REMOVED BY THE DESIGNER PRIOR TO INSERTION OF THE SHEET INTO THE PLAN SET.
- THE DESIGNER SHALL ADJUST DETAIL AND QUANTITIES AS REQUIRED FOR NUMBER OF VES CAMERAS.
- THE DESIGNER SHALL INCLUDE VIDEO POWER JUNCTION BOX DETAILS (M-ITS-2100 SERIES BASE SHEETS) FOR SECURITY CAMERAS AND DATA LOGGER CAMERA.

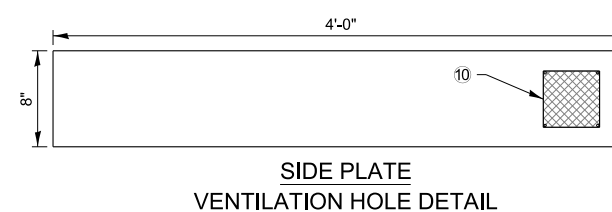
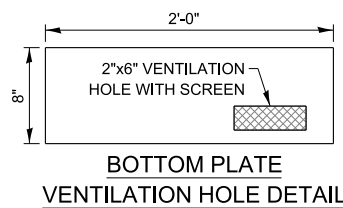

**NOTES:**

- LABEL JUNCTION BOX, TERMINAL STRIPS, AND ALL WIRE AND CABLES.
- ROUTE 1-2/C #12 POWER CABLE TO EACH CAMERA.
- ALL ELECTRICAL CABLES TO CAMERA SHALL HAVE SURGE PROTECTION.
- CAT6 CABLE SHALL BE SURGE PROTECTED ON THE TSIC.



**VIDEO POWER JUNCTION BOX  
DETAIL - REMOTE PLAZA**

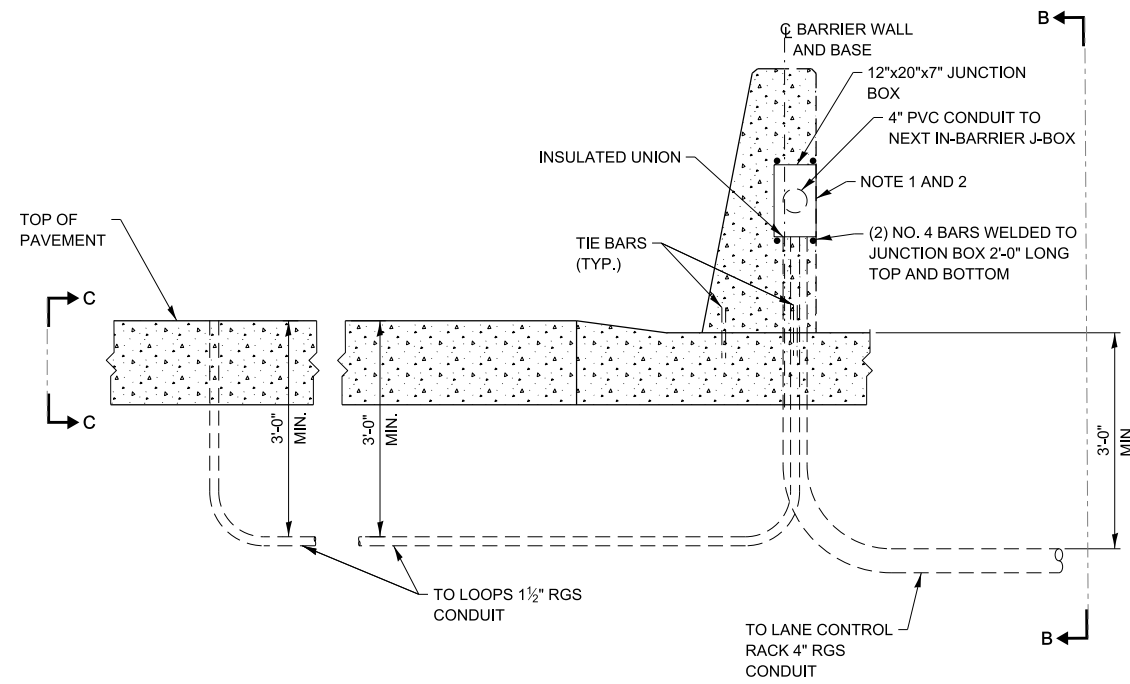

SECTION A-A  
(LANE LOOP LAYOUT)  
NOT TO SCALE

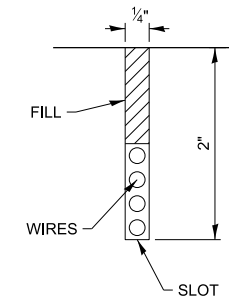

DETAIL OF  
DETECTOR LOOP SLOT  
NOT TO SCALE

NOTES:

1. SEE LOOP LAYOUT SHEETS FOR MORE DETAILS.
2. THE REINFORCEMENT IS NOT SHOWN FOR CLARITY.
3. CONDUITS THAT STUB UP IN THE PAVEMENT ARE 1 1/2" FOR QUANTUM AND PIEZO STRIPS, 1 1/2" FOR ALL OTHERS UNLESS NOTED OTHERWISE. SEE LOOP LAYOUT DETAIL. CONDUIT BETWEEN JUNCTION BOXES SHALL BE 4" DIA.
4. ELECTRICAL CONTRACTOR MUST COORDINATE WITH ILLINOIS TOLLWAY AND PAVEMENT CONTRACTOR. NO CONCRETE POUR SHALL BE DONE BEFORE CONDUIT IS LAID OUT AND APPROVED BY THE ENGINEER.
5. JUNCTION BOXES MUST BE INSTALLED A MINIMUM OF 12" APART.

**NOTE TO DESIGNER**

THIS BASE SHEET SHOWS TYPICAL CONSTRUCTION BUT IT IS **NOT** A STANDARD DRAWING. IT REQUIRES COMPLETION BY THE DESIGNER PRIOR TO INSERTION INTO A CONTRACT. MICROSTATION FILES AND THE "CADD STANDARDS MANUAL" ARE AVAILABLE ON THE ILLINOIS TOLLWAY WEBSITE. THE DESIGNER SHALL ACCEPT THE RESPONSIBILITY OF THE DESIGN OF THIS SHEET UPON ITS COMPLETION AND INSERTION INTO A CONTRACT. ALL "NOTE TO DESIGNER" BOXES SHALL BE REMOVED BY THE DESIGNER PRIOR TO INSERTION OF THE SHEET INTO THE PLAN SET.

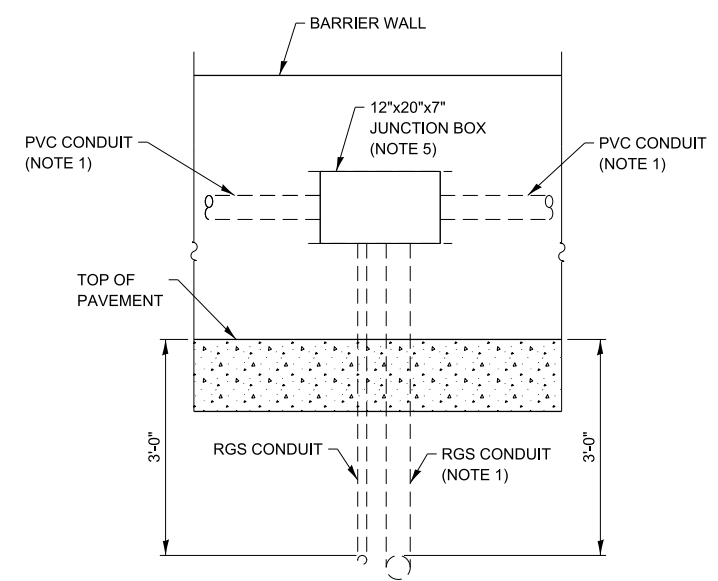

ELEVATION B-B  
EMBEDDED JUNCTION BOX IN  
BARRIER WALL ELEVATION  
NOT TO SCALE

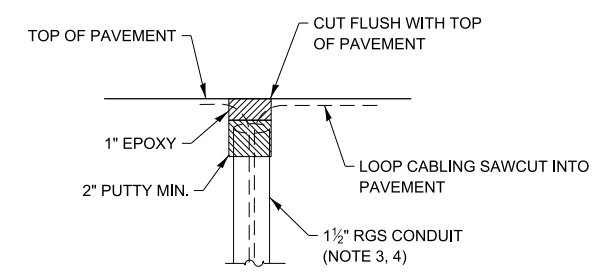

SECTION C-C  
LOOP INSTALLATION DETAILS  
NOT TO SCALE

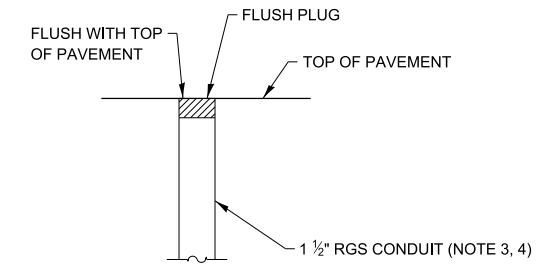

SECTION C-C  
PRIOR TO ROAD OR  
ISLAND CONSTRUCTION  
NOT TO SCALE

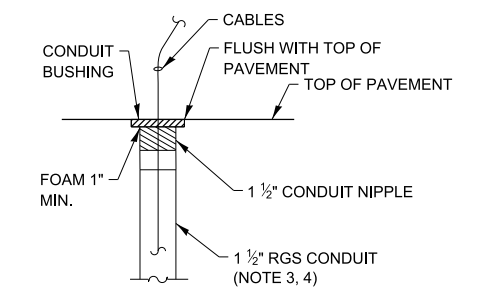

SECTION C-C  
EQUIPMENT ENDS AFTER  
CABLE INSTALLATION  
NOT TO SCALE



LOOP JUNCTION BOX DETAIL

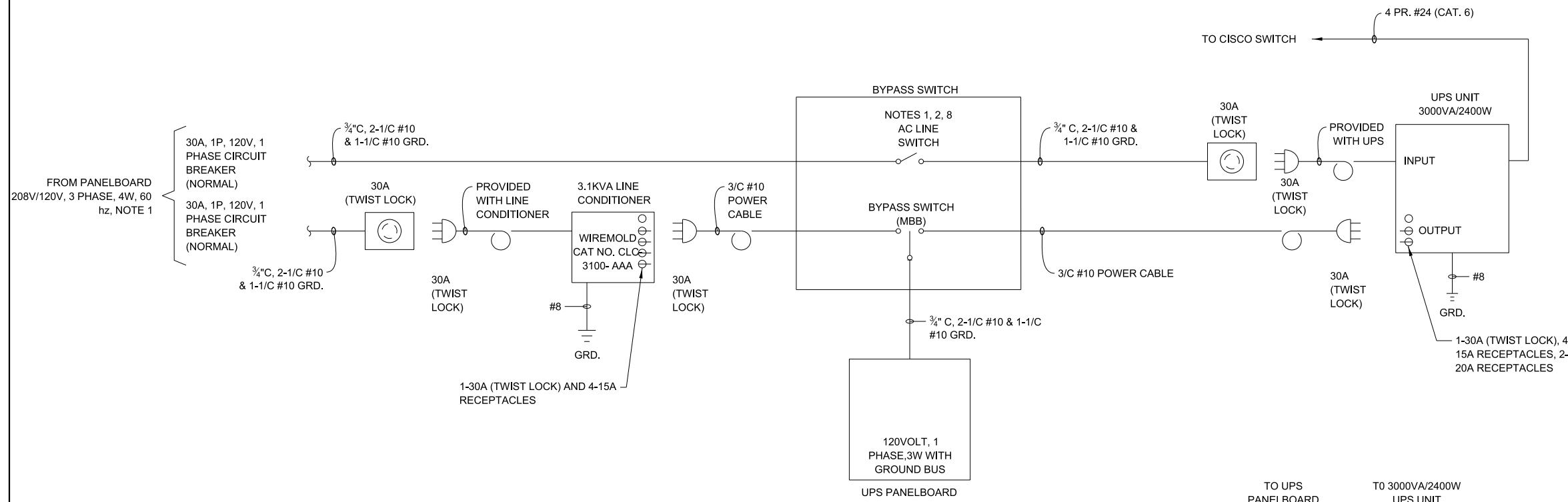

**SAMPLE UPS SINGLE LINE DIAGRAM  
3000VA SHOWN**

NOTE TO DESIGNER  
RESERVED

**NOTES:**

1. PHASING MUST BE THE SAME ALL THROUGH SYSTEM.
2. REMOVE FLAT PLATE JUMPER BETWEEN DUAL PINS 8 - 8 AND 9 - 9 AS DIRECTED BY THE MANUFACTURER TO PROVIDE FOR TWO POWER SOURCES.
3. BOTH SWITCHES SHOWN IN "OFF" POSITION.
4. INPUT AND OUTPUT VOLTAGE IS 120 VOLT, 1 PHASE, 60 HERTZ, 3 WIRE.
5. CONDUIT SIZE SHOWN IS BASED ON TYPE THHN/THWN WIRE.
6. THE UPS SHALL BE AS MANUFACTURED BY EATON. THE BYPASS SWITCH SHALL BE AS MANUFACTURED BY POWERWARE, INC. THE LINE CONDITIONER SHALL BE AS MANUFACTURED BY WIREMOLD ELECTRONICS.
7. DASHED LINES INDICATE INTERNAL WIRING. SOLID LINES INDICATE EXTERNAL WIRING.
8. ELECTRICAL CONTRACTOR MODIFIES BYPASS SWITCH IN FIELD BY ADDING 30A (TWIST LOCK) RECEPTACLE.
9. VERIFY DETAILS WITH ILLINOIS TOLLWAY PRIOR TO PURCHASING EQUIPMENT

NOTE TO DESIGNER

THIS BASE SHEET SHOWS TYPICAL CONSTRUCTION BUT IT IS NOT A STANDARD DRAWING. IT REQUIRES COMPLETION BY THE DESIGNER PRIOR TO INSERTION INTO A CONTRACT. MICROSTATION FILES AND THE "CADD STANDARDS MANUAL" ARE AVAILABLE ON THE ILLINOIS TOLLWAY WEBSITE. THE DESIGNER SHALL ACCEPT THE RESPONSIBILITY OF THE DESIGN OF THIS SHEET UPON ITS COMPLETION AND INSERTION INTO A CONTRACT. ALL "NOTE TO DESIGNER" BOXES SHALL BE REMOVED BY THE DESIGNER PRIOR TO INSERTION OF THE SHEET INTO THE PLAN SET.

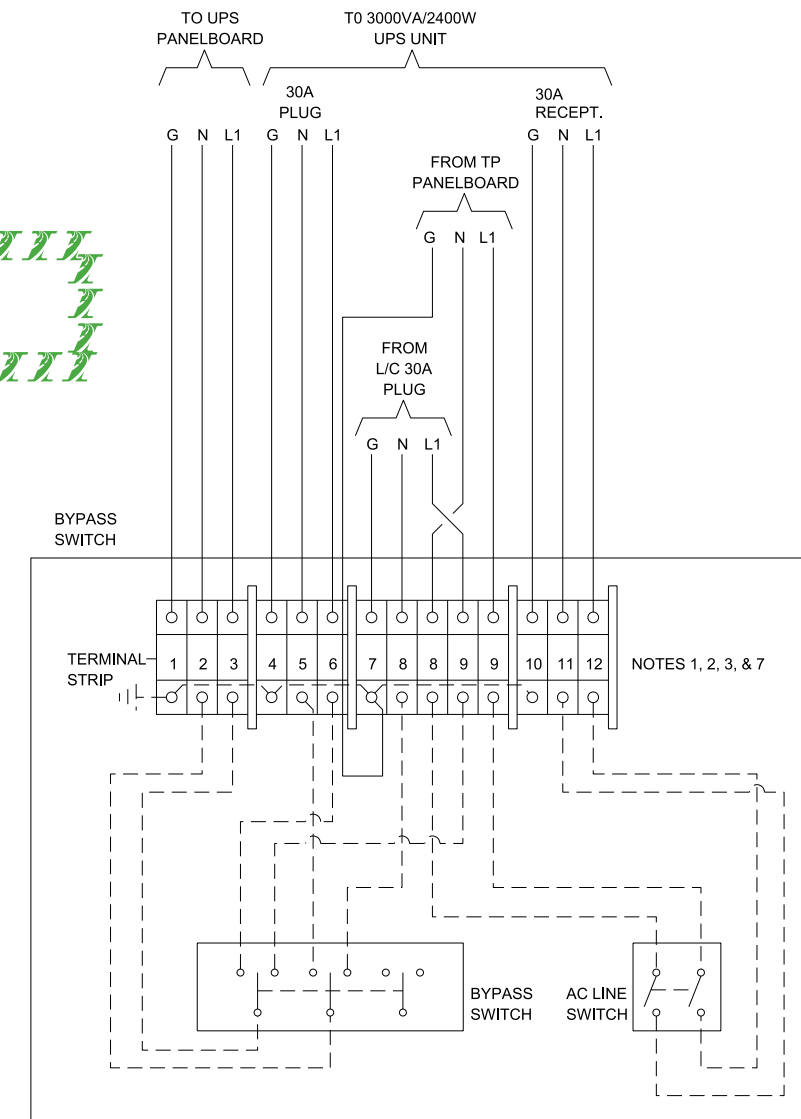

**BYPASS SWITCH WIRING DIAGRAM**



**UPS SINGLE LINE AND WIRING DIAGRAM**

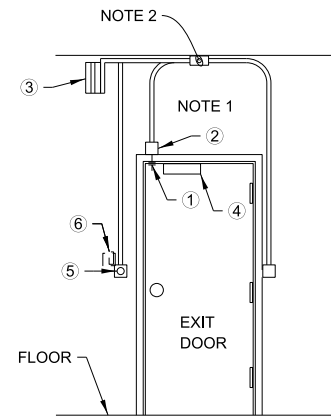



**DOOR ALARM JUNCTION BOX DETAIL- SINGLE DOOR**  
NOT TO SCALE

**EQUIPMENT LEGEND - DOOR ALARM**

ITEM	DESCRIPTION
①	NORMALLY CLOSED (N.C. WHEN THE DOOR IS CLOSED) MAG REED CONTACT BUILT INTO DOOR FRAME. SENTROL 1078C OR 1078 SERIES. COIL CONTACT LEADS AND COMMUNICATION CABLE IN JUNCTION BOX.
②	JUNCTION BOX, 4" X 4" WITH BLANK COVER PLATE, AND 3/4" CONDUIT TO CABLE TRAY.
③	MOTION DETECTOR
④	MAGNETIC DOOR LOCK
⑤	DOOR RELEASE BUTTON
⑥	CARD READER (EXTERIOR)

**NOTES:**

1. COIL 2 FEET CABLE IN BOX FOR TERMINATION BY THE ILLINOIS TOLLWAY UNLESS OTHERWISE NOTED.
2. ROUTE TO CARD READER PANEL, TERMINATION BY THE ILLINOIS TOLLWAY. 4-1PR #22 SHLD. CABLE IN 3/4" CONDUIT.
3. MECHANICAL LOCKS SHALL BE SCHLAGE BRAND (OR APPROVED EQUAL) AND SECURED WITH A CONSTRUCTION KEY WITH THREE COPIES PROVIDED TO ILLINOIS TOLLWAY BUSINESS SYSTEMS.

  
**NOTE TO DESIGNER**  
 THIS BASE SHEET SHOWS TYPICAL CONSTRUCTION BUT IT IS NOT A STANDARD DRAWING. IT REQUIRES COMPLETION BY THE DESIGNER PRIOR TO INSERTION INTO A CONTRACT. MICROSTATION FILES AND THE "CADD STANDARDS MANUAL" ARE AVAILABLE ON THE ILLINOIS TOLLWAY WEBSITE. THE DESIGNER SHALL ACCEPT THE RESPONSIBILITY OF THE DESIGN OF THIS SHEET UPON ITS COMPLETION AND INSERTION INTO A CONTRACT. ALL "NOTE TO DESIGNER" BOXES SHALL BE REMOVED BY THE DESIGNER PRIOR TO INSERTION OF THE SHEET INTO THE PLAN SET.  



**DOOR ALARMS DETAIL**

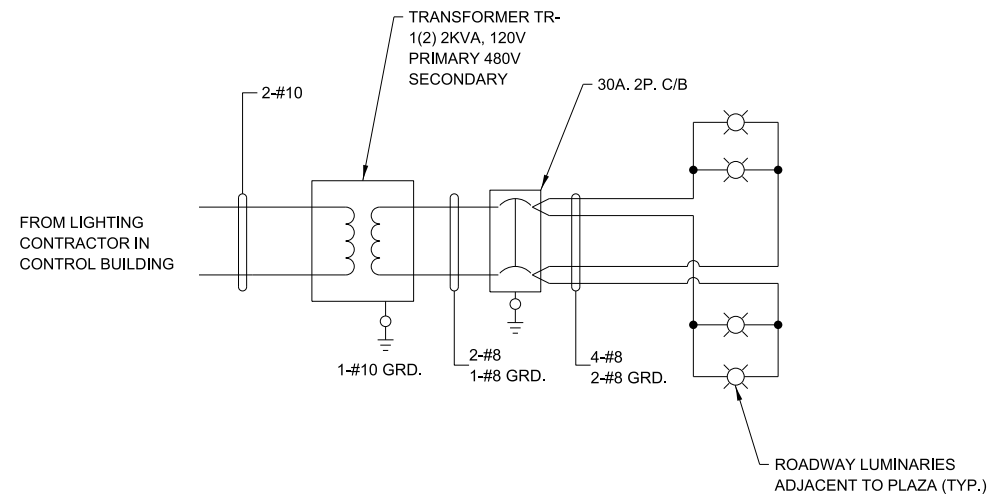

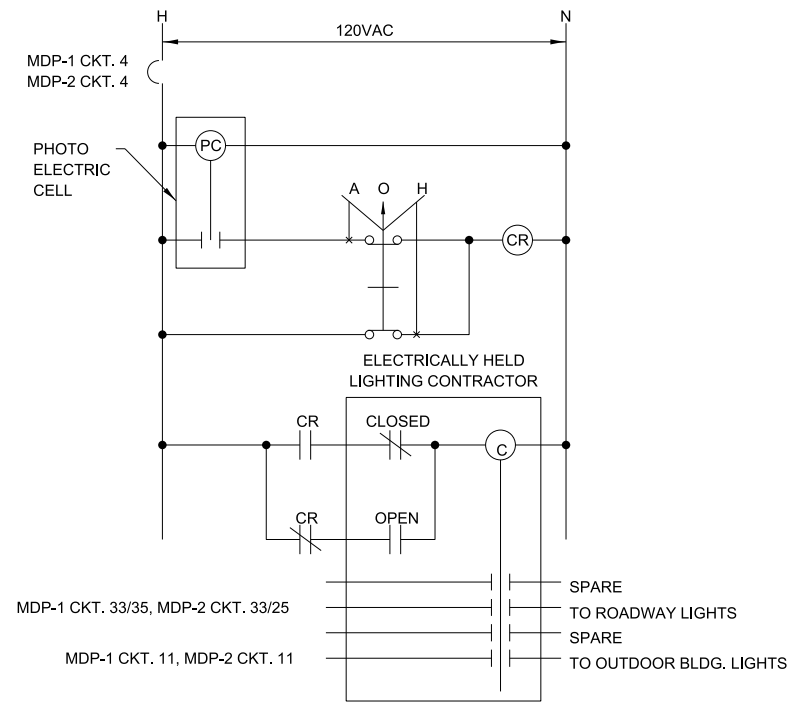

**SCHMATIC WIRING DIAGRAM  
EMERGENCY ROADWAY PLAZA LIGHTING**



**LIGHTING CONTRACTOR WIRING DIAGRAM**

**NOTES:**



1. SEE SYMBOLS AND ABBREVIATIONS SHEET FOR LEGEND.
2. SEE PLANS FOR CABLE AND CONDUIT ROUTING.

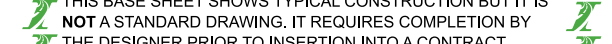
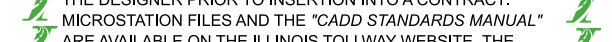

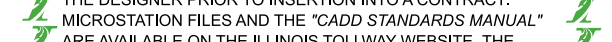
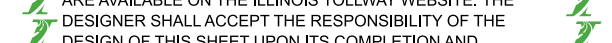
  
**NOTE TO DESIGNER**  

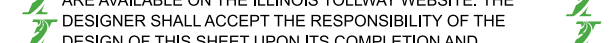
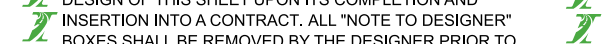

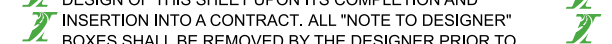
 THIS BASE SHEET SHOWS TYPICAL CONSTRUCTION BUT IT IS 



 **NOT** A STANDARD DRAWING. IT REQUIRES COMPLETION BY 



 THE DESIGNER PRIOR TO INSERTION INTO A CONTRACT. 



 MICROSTATION FILES AND THE "CADD STANDARDS MANUAL" 



 ARE AVAILABLE ON THE ILLINOIS TOLLWAY WEBSITE. THE 

 DESIGNER SHALL ACCEPT THE RESPONSIBILITY OF THE 

 DESIGN OF THIS SHEET UPON ITS COMPLETION AND 

 INSERTION INTO A CONTRACT. ALL "NOTE TO DESIGNER" 

 BOXES SHALL BE REMOVED BY THE DESIGNER PRIOR TO 

 INSERTION OF THE SHEET INTO THE PLAN SET. 





**MISCELLANEOUS SCHEMATIC  
DIAGRAMS**

**NOTE TO DESIGNER**

THIS BASE SHEET SHOWS TYPICAL CONSTRUCTION BUT IT IS NOT A STANDARD DRAWING. IT REQUIRES COMPLETION BY THE DESIGNER PRIOR TO INSERTION INTO A CONTRACT. MICROSTATION FILES AND THE "CADD STANDARDS MANUAL" ARE AVAILABLE ON THE ILLINOIS TOLLWAY WEBSITE. THE DESIGNER SHALL ACCEPT THE RESPONSIBILITY OF THE DESIGN OF THIS SHEET UPON ITS COMPLETION AND INSERTION INTO A CONTRACT. ALL "NOTE TO DESIGNER" BOXES SHALL BE REMOVED BY THE DESIGNER PRIOR TO INSERTION OF THE SHEET INTO THE PLAN SET.

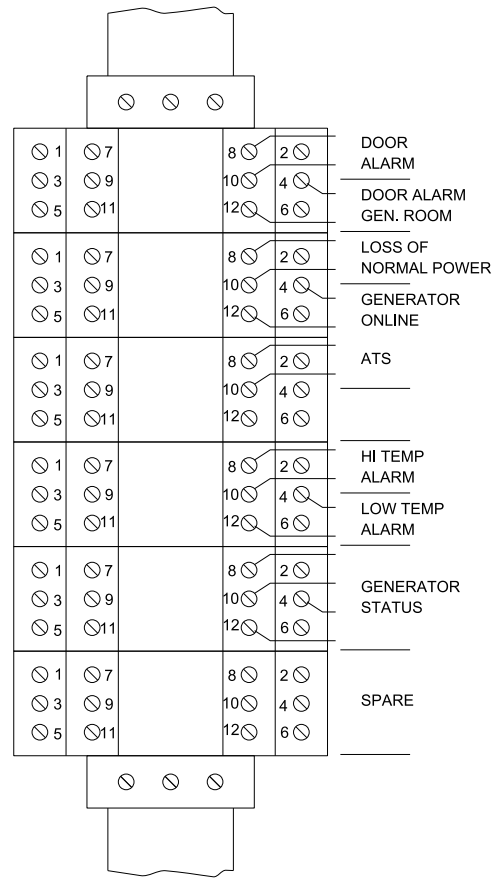
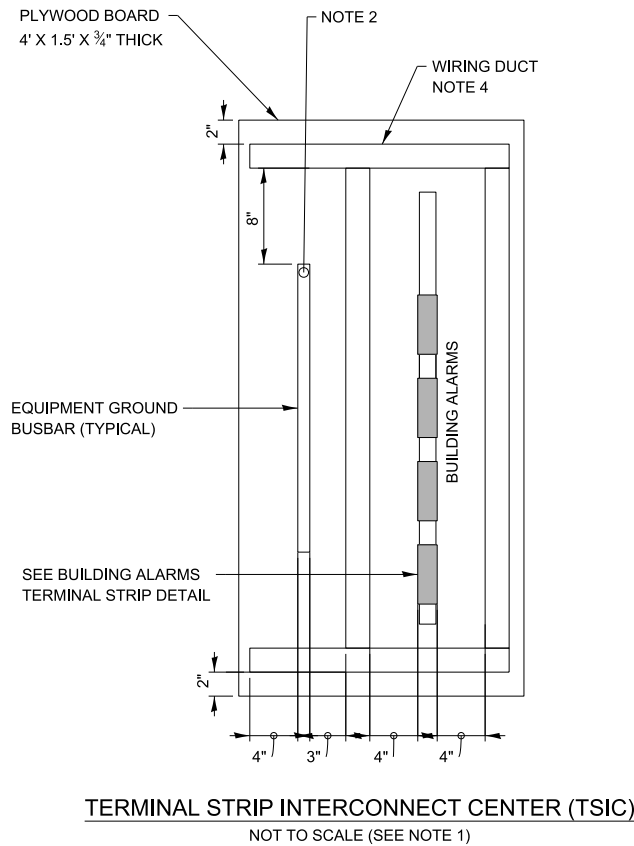

**BUILDING ALARMS TERMINAL STRIP**  
NOT TO SCALE

**NOTES:**

1. TERMINAL STRIP INTERCONNECT CENTER (TSIC) IS LOCATED IN THE CONTROL BUILDING. SEE BUILDING EQUIPMENT LAYOUT DRAWINGS, FOR LOCATION.
2. ROUTE #6 COPPER GROUND CABLE FROM GROUND BUSBAR TO INTERNAL PERIMETER GROUND BUS CONDUCTOR.
3. ALL EQUIPMENT SHALL BE FURNISHED AND INSTALLED BY THE CONTRACTOR UNLESS OTHERWISE NOTED.
4. PROVIDE WIRE DUCT AS SHOWN ON THE DRAWING. WIRE DUCT SHALL BE PANDUIT PART NUMBER E2X3LG6 WITH COVER PART NUMBER C2LG6 AND CORNER STRIP PART NUMBER CSP3LG-Q.

3 PAIR DATA/COMMUNICATIONS CABLE COLOR CODE CHART	
PAIR NO.	MFGR'S COLOR CODE CHART COLOR COMBINATION
CABLE-1	
1	BLACK PAIRED WITH RED
2	BLACK PAIRED WITH WHITE
3	BLACK PAIRED WITH GREEN
3 PR. #22 CABLE WITH INDIVIDUALLY SHIELDED PAIRS SHALL BE BELDEN #88777 OR MANHATTAN #M43103.	

6 PAIR DATA/COMMUNICATIONS CABLE COLOR CODE CHART	
PAIR NO.	MFGR'S COLOR CODE CHART COLOR COMBINATION
CABLE-2	
1	BLACK PAIRED WITH RED
2	BLACK PAIRED WITH WHITE
3	BLACK PAIRED WITH GREEN
4	BLACK PAIRED WITH BLUE
5	BLACK PAIRED WITH YELLOW
6	BLACK PAIRED WITH BROWN
6 PR. #22 CABLE WITH INDIVIDUALLY SHIELDED PAIRS SHALL BE BELDEN #88778 OR MANHATTAN #M43106	

9 CONDUCTOR ALARM CABLE COLOR CODE CHART	
CONDUCTOR NO.	MFGR'S COLOR CODE CHART COLOR COMBINATION
CABLE-3	
1	BLACK
2	WHITE
3	RED
4	GREEN
5	ORANGE
6	BLUE
7	WHITE/BLACK
8	RED/BLACK
9	GREEN/BLACK
9 CONDUCTOR #22 SHIELDED CABLE SHALL BE BELDEN #83559.	



**TSIC TERMINAL BLOCK LAYOUT MAIN AND REMOTE PLAZAS - AET LANES**

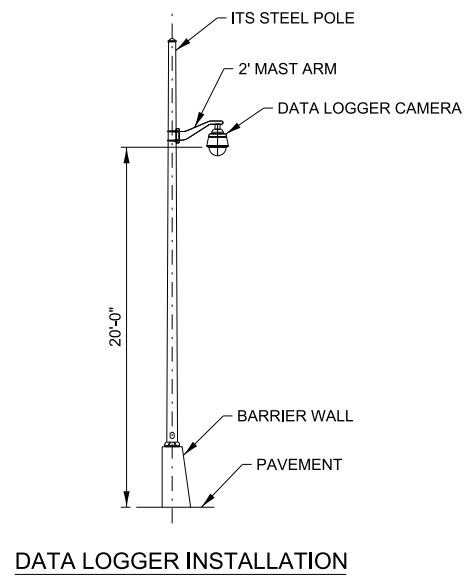
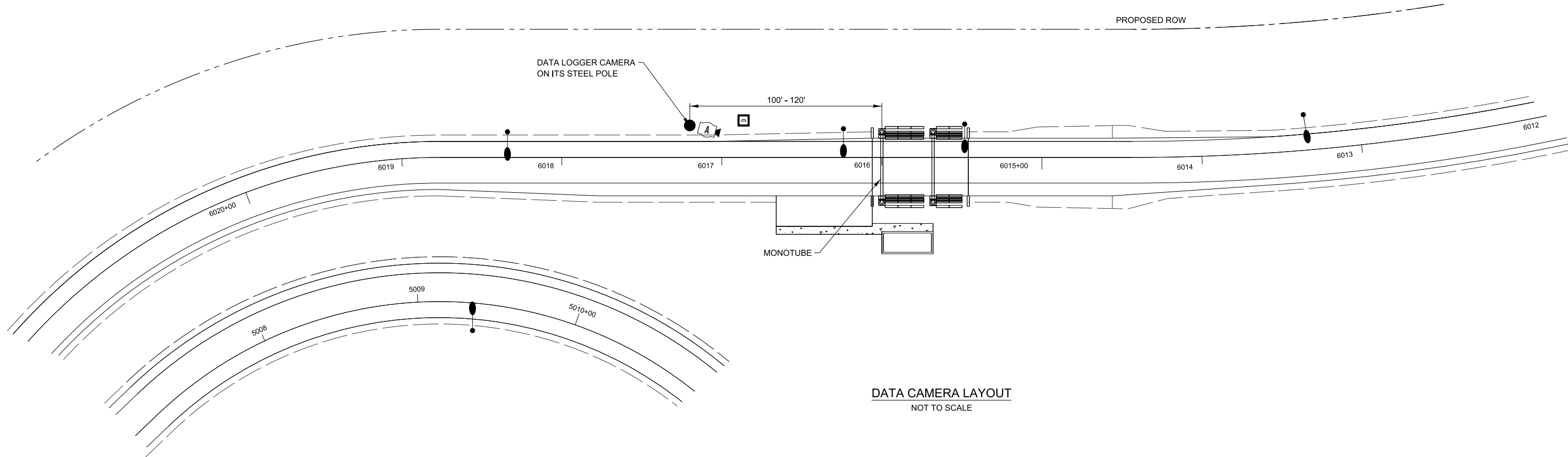

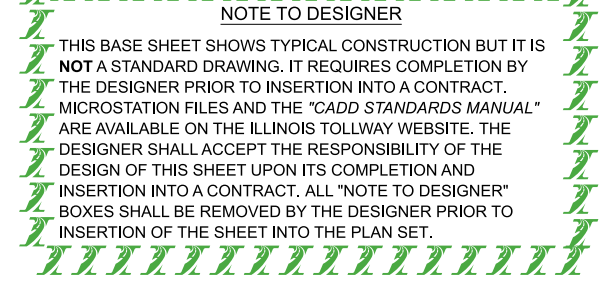
  
**NOTE TO DESIGNER**
  

THIS BASE SHEET SHOWS TYPICAL CONSTRUCTION BUT IT IS NOT A STANDARD DRAWING. IT REQUIRES COMPLETION BY THE DESIGNER PRIOR TO INSERTION INTO A CONTRACT. MICROSTATION FILES AND THE "CADD STANDARDS MANUAL" ARE AVAILABLE ON THE ILLINOIS TOLLWAY WEBSITE. THE DESIGNER SHALL ACCEPT THE RESPONSIBILITY OF THE DESIGN OF THIS SHEET UPON ITS COMPLETION AND INSERTION INTO A CONTRACT. ALL "NOTE TO DESIGNER" BOXES SHALL BE REMOVED BY THE DESIGNER PRIOR TO INSERTION OF THE SHEET INTO THE PLAN SET.

**NOTES:**

1. SEE CABLE/CONDUIT SCHEDULES SHEET FOR CABLE TAGS.
2. INSTALL CABLES BETWEEN THE PLAZA AND CAMERA PER MANUFACTURER'S RECOMMENDATIONS.
3. THE CAMERA'S FINAL MOUNTING LOCATION SHALL BE APPROVED BY THE ENGINEER PRIOR TO INSTALLATION.
4. THE COST FOR THE WORK TO FURNISH AND INSTALL THE CAMERA, CABLES, CONDUIT, AND ASSOCIATED MOUNTING HARDWARE ON THE POLE SHALL BE INCLUDED IN THE LUMP SUM PAY ITEM FOR ELECTRICAL WORK FOR THE PLAZA.
5. LOOP 3' OF CABLE FOR CAMERA IN POLE TO FACILITATE CAMERA MAINTENANCE.



**DATA LOGGER CAMERA**

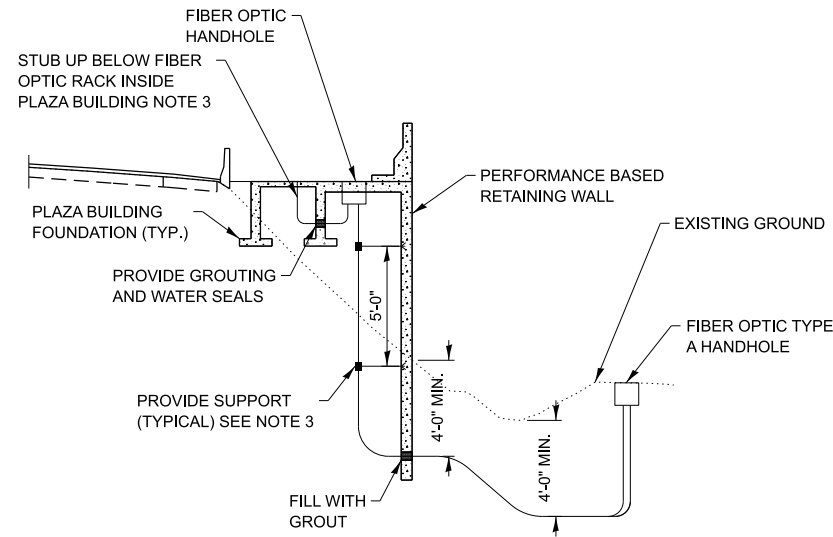

DETAIL FOR FIBER STUB UP

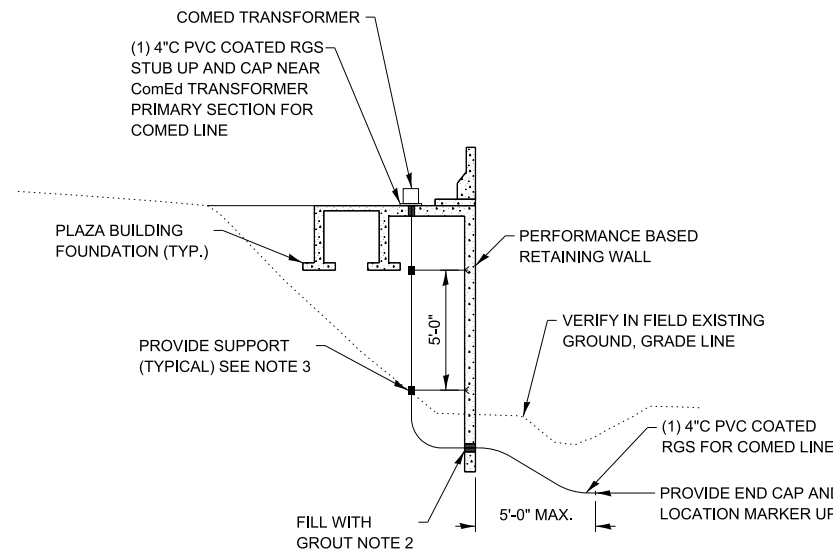

DETAIL FOR COMED LINE STUB UP

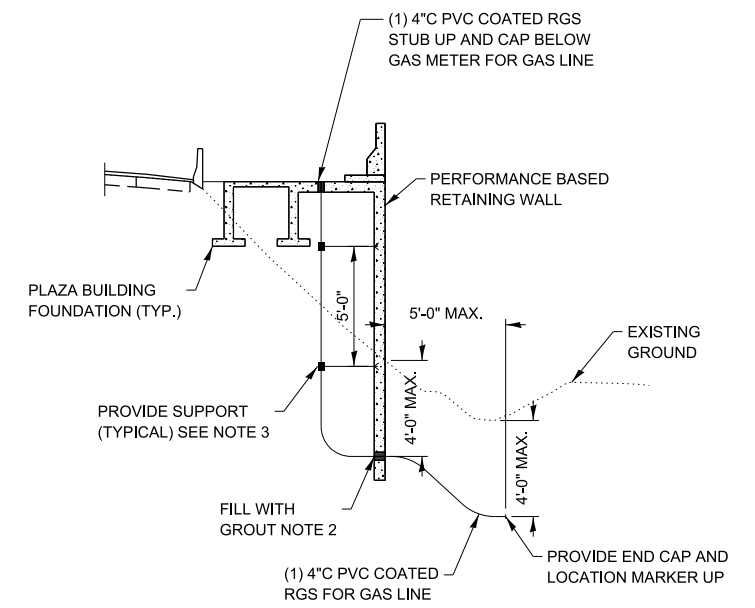

DETAIL FOR GAS LINE STUB UP

NOTES:

1. DETAILS ARE ONLY SCHEMATICS FOR GUIDANCE, AND CONTRACTOR MUST COORDINATE WITH COMED AND NICOR GAS SERVICE LINES.
2. CONTRACTOR SHALL COORDINATE WITH STRUCTURAL FOR LOCATION OF OPENINGS THROUGH RETAINING WALL. THE HOLE DIA./SLOT SHALL BE LARGE ENOUGH SO THAT IT DOES NOT CAUSE ANY STRAIN ON UTILITY DUE TO SETTLEMENT OF THE WALL.
3. SUPPORTS ARE REQUIRED TO HOLD THE SLEEVES VERTICALLY BEFORE FILL UP ONLY. THIS HAS TO BE COORDINATED WITH COMED AND NICOR UTILITIES. PROVIDE CONDUIT CLAMP/ANCHOR BOLT OF POWER STRUT, B-LINE OR UNISTRUT AND MOUNTING HARDWARE.
4. ALL DIMENSIONS AND REINFORCEMENT SHALL BE PER ILLINOIS TOLLWAY STANDARD DRAWING H8 FOR TYPE 1 CENTERED CAISSON, 42" BARRIER.

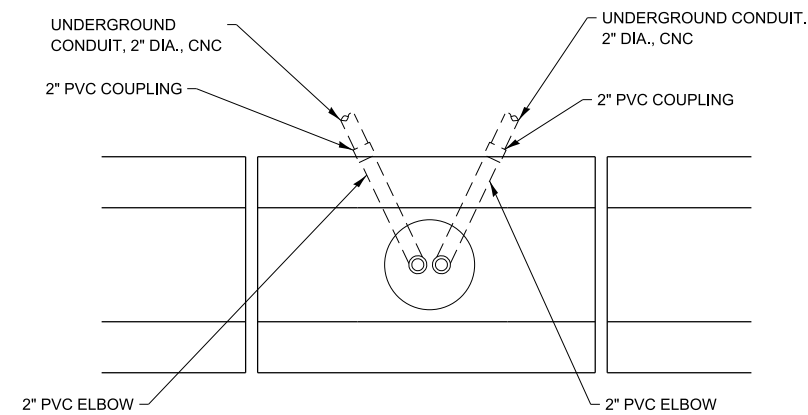

PLAN - DOUBLE FACE BARRIER

**NOTE TO DESIGNER**  
 THIS BASE SHEET SHOWS TYPICAL CONSTRUCTION BUT IT IS NOT A STANDARD DRAWING. IT REQUIRES COMPLETION BY THE DESIGNER PRIOR TO INSERTION INTO A CONTRACT. MICROSTATION FILES AND THE "CADD STANDARDS MANUAL" ARE AVAILABLE ON THE ILLINOIS TOLLWAY WEBSITE. THE DESIGNER SHALL ACCEPT THE RESPONSIBILITY OF THE DESIGN OF THIS SHEET UPON ITS COMPLETION AND INSERTION INTO A CONTRACT. ALL "NOTE TO DESIGNER" BOXES SHALL BE REMOVED BY THE DESIGNER PRIOR TO INSERTION OF THE SHEET INTO THE PLAN SET.

**NOTE TO DESIGNER**  
 THIS BASE SHEET REFLECTS THE USE OF PERFORMANCE BASED RETAINING WALL. THE DESIGNER SHALL MODIFY THE BASE SHEETS ACCORDINGLY FOR DESIGNED RETAINING WALLS.

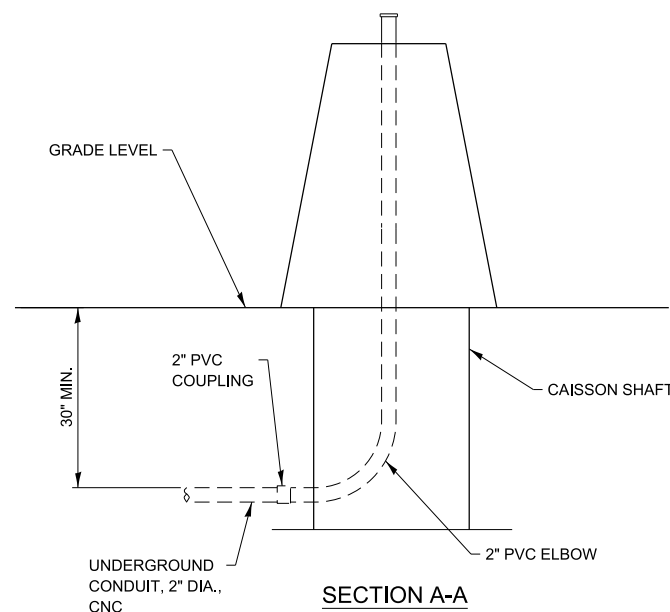

SECTION A-A

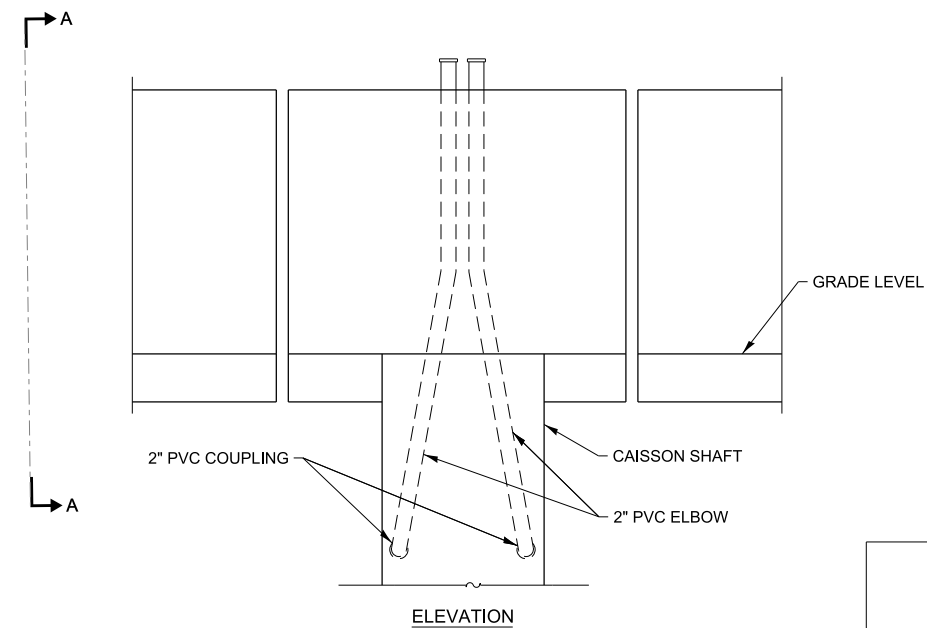

ELEVATION  
 CONDUIT DETAIL AT LIGHT POLE FOUNDATION  
 INTEGRAL WITH BARRIER WALL  
 (NOT TO SCALE)



MISCELLANEOUS CROSS SECTION DETAILS

**1-PH COMPT TR PAD - ESS/RSS**

167kVA MAXIMUM CAPACITY

ITEM	CAT ID	DESCRIPTION	TABLE-1	CAT ID	UNIT	QUANTITY
A	GROUNDING INSTALLATION	CRSSO_GG	(1)		A	1
B	WIRE, COPPER, OVERHEAD, BARE, 1/0, 19 STR, SOFT DRAWN TINNED, 3		(1)	0000355082	FT	35
C	CONNECTOR, COMPRESSION, 1/0 OR 2/0 STR CU, RUN & TAP, BURNDY C		(1)	0000358545	EA	1

- NOTES:**
- APPLICATION:**
- THIS STANDARD SHALL BE USED FOR THE INSTALLATION OF AN ELECTRIC OR RESIDENTIAL SERVICE STATION FOUNDATION AS DESCRIBED IN "ComEd's GENERAL TERMS AND CONDITIONS".
  - WHEN BARE LEAD COVERED CABLES ARE LOCATED OR PLANNED WITHIN 200 FEET, OMIT ITEM "C" AND REPLACE WITH 1/0 LEAD CLAD COPPER CONDUCTOR (CATID 0000360809). SPECIFY STAINLESS STEEL GROUNDS PER 08550.C00.
  - PRECAST ALTERNATIVES TO THIS POURED DESIGN MAY BE AVAILABLE. CONTACT CONSTRUCTION STANDARDS GROUP.
  - AFTER PRIMARY AND SECONDARY CONDUITS ARE IN PLACE, BACKFILL WITH SCREENINGS, SAND, OR FINE EXCAVATED MATERIAL. COMPACT THOROUGHLY BEFORE POURING FOUNDATION.
  - CONCRETE TO BE IN ACCORDANCE WITH THE LATEST EDITION OF THE APPLICABLE ACI CODE AND AIR ENTRAINMENT. IT SHALL HAVE A MINIMUM COMPRESSIVE STRENGTH OF 3000 PSI AT 28 DAYS. AIR ENTRAINMENT SHALL BE 4 TO 7 PERCENT OF THE VOLUME OF CONCRETE.
- INFORMATION:**
- THE CUSTOMER TO INSTALL THE TRANSFORMER FOUNDATION, 1 INCH CONDUITS, AND TRENCH FOR ComEd GROUND WIRE.
  - ComEd TO PROVIDE AND INSTALL THE GROUND WIRE AND GRID.
  - CONCRETE TO BE IN ACCORDANCE WITH THE LATEST EDITION OF THE APPLICABLE ACI CODE AND AIR ENTRAINMENT. IT SHALL HAVE A MINIMUM COMPRESSIVE STRENGTH OF 3000 PSI AT 28 DAYS. AIR ENTRAINMENT SHALL BE 4 TO 7 PERCENT OF THE VOLUME OF CONCRETE.

- TOP OF FOUNDATION TO BE SMOOTH AND LEVEL.
- GRADE AWAY FROM FOUNDATION. FINAL GRADE SHALL BE WELL DRAINED AT ALL TIMES.
- PRIMARY AND SECONDARY CONDUIT MUST COME THROUGH FOUNDATION IN DESIGNATED AREAS.
- SEE C7723 FOR BURNDY-HUSKY DIE SET CROSS REFERENCE.
- DO NOT PLACE CONDUITS UNDER THIS SECTION OF FOUNDATION IF AVAILABLE.
- DO NOT DISTURB EARTH IN FOUNDATION AREA MORE THAN NECESSARY WHEN INSTALLING CONDUIT.
- TERMINATE PRIMARY AND SECONDARY CONDUITS FLUSH WITH TOP OF FOUNDATION.
- BOX OUT CONDUIT OPENING.
- SECONDARY CONDUIT LOCATION.
- PRIMARY CONDUIT LOCATION.
- CONSULT SPILL PREVENTION, CONTROL AND COUNTERMEASURES (SPCC) PROGRAM OR ENVIRONMENTAL SERVICES IF TOTAL OIL CAPACITY EQUAL TO OR EXCEEDING 1320 GALLONS EXISTS OR IS PLANNED AT ESS/RS SITE.

**TABLE-B**  
**PRESSING TABLE**

ITEM	TOOL & DIE	NO. OF CRIMPS
D	U-O	1
	U-E	3

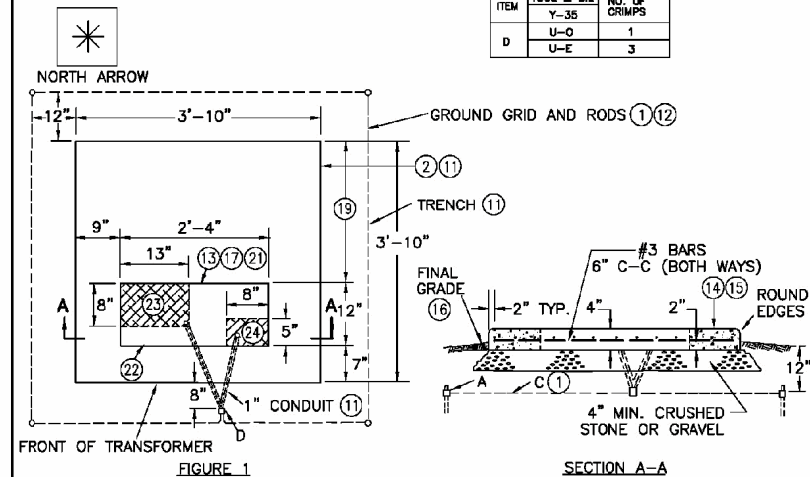

© Notice: The information contained on this page is the sole property of EXELON and is to be used only in conjunction with electric service provided by EXELON.

**Exelon** SYSTEM STANDARD  
 Energy Delivery

**NOTE:**

CONCRETE PAD DETAIL FOR PROPOSED 480/240 V, SINGLE PHASE TRANSFORMER FOR ROADWAY LIGHTING CONTROLLER.

**3-PH RADIAL COMPT TR PAD - ESS**

SIZE OF TRANSFORMER

C5286.B	45 - 225kVA 120/208V
C	112.5 - 300kVA 120/208V
D	225 - 500kVA 120/208V
E	750kVA 120/208V
F	45 - 75kVA 277/480V
G	112.5 - 300kVA 277/480V
H	225 - 500kVA 277/480V
J	1500 - 2500kVA 277/480V
K	500 - 750kVA 4kV
L	1000 - 2500kVA 4kV

ITEM	CAT ID	DESCRIPTION	TABLE-1	CAT ID	UNIT	QUANTITY
A	GROUNDING INSTALLATION	CRSSO_GG	(1)		A	1
B	WIRE, COPPER, OVERHEAD, BARE, 1/0, 19 STR, SOFT DRAWN TINNED, 3		(1)	0000355082	FT	50
C	CONNECTOR, COMPRESSION, 1/0 OR 2/0 STR CU, RUN & TAP, BURNDY C		(2)	0000358545	EA	2

- NOTES:**
- APPLICATION:**
- THIS STANDARD SHALL BE USED TO INSTALL AN ELECTRIC SERVICE STATION FOUNDATION FOR A 3-PH RADIAL-FEED COMPARTMENTAL TRANSFORMER AS DESCRIBED IN "ComEd's GENERAL TERMS AND CONDITIONS".
  - WHEN BARE LEAD COVERED CABLES ARE LOCATED OR PLANNED WITHIN 200 FEET, REPLACE ITEM "B" WITH 1/0 LEAD CLAD COPPER CONDUCTOR (CAT ID 0000360809) AND SPECIFY GROUND RODS IN ACCORDANCE WITH CRSSO.
  - WHEN JUNCTION CABINET IS USED, ADD ONE OF ITEM "C" AND ADD 15 FEET OF ITEM "B".
  - STEEL PLATE NOT FURNISHED WITH STANDARD. ORDER FROM JUNCTION CABINET MANUFACTURER OR LOCAL VENDOR.
  - CUSTOMER SHALL SUPPLY AND INSTALL ALL ITEMS WITHIN THIS STANDARD EXCEPT FOR THE GROUNDING MATERIAL.
  - PRECAST ALTERNATIVES TO THIS POURED DESIGN MAY BE AVAILABLE. CONTACT DISTRIBUTION ENGINEERING DEPARTMENT FOR DETAILS.
  - DO NOT PLACE CONDUITS UNDER THIS SECTION OF FOUNDATION IF AVAILABLE.
  - DO NOT DISTURB GROUND IN FOUNDATION AREA MORE THAN NECESSARY WHEN INSTALLING CONDUIT.
  - PRIMARY AND SECONDARY CONDUIT MUST COME THROUGH FOUNDATION IN DESIGNATED AREAS.
  - CONDUIT SHALL TERMINATE FLUSH WITH THE TOP OF THE FOUNDATION UNLESS OTHERWISE DESIGNATED.
  - IF METAL CONDUIT IS USED, THE GROUNDING BUSHING SHALL NOT PROTRUDE ABOVE THE TOP OF THE FOUNDATION.
  - AFTER PRIMARY AND SECONDARY CONDUITS ARE IN PLACE, BACKFILL WITH SCREENINGS, SAND OR FINE EXCAVATED MATERIAL. COMPACT THOROUGHLY BEFORE POURING FOUNDATION.
  - CONCRETE SHALL BE IN ACCORDANCE WITH THE LATEST EDITION OF THE APPLICABLE ACI CODE. IT SHALL HAVE A MINIMUM COMPRESSIVE STRENGTH OF 3000 PSI AT 28 DAYS. AIR ENTRAINMENT SHALL BE 4 TO 7% OF THE VOLUME OF CONCRETE.
  - TOP OF THE FOUNDATION SHALL BE SMOOTH AND LEVEL.
  - GROUND GRID CONSISTS OF A CONTINUOUS COPPER GROUND LOOP. BRING ONE TAIL OF GROUND LOOP INTO EACH OPENING IN FOUNDATION. CONNECT GROUND CABLE (ITEM "D") TO GROUND RODS AS SHOWN IN CRSSO. CLOSE LOOP WITH COMPRESSION CONNECTOR (ITEM "C").
  - WHEN LEAD CLAD CABLE IS USED FOR THE GROUND CABLE, COVER THE ITEM "C" CONNECTION WITH MOISTURE SEALING COMPOUND AND PLASTIC TAPE AS SHOWN IN DETAIL-1.
  - FINAL GRADE SHALL SLOPE AWAY FROM FOUNDATION. FINAL GRADE SHALL BE WELL DRAINED AT ALL TIMES.
  - A JUNCTION CABINET IS REQUIRED IF SECONDARY CONDUIT SPACE REQUIREMENTS EXCEED LIMITS SPECIFIED IN TABLE-A. REFER TO PAGE 3 FOR DETAILS OF NECESSARY FOUNDATION.
  - CONTACT DISTRIBUTION ENGINEERING DEPARTMENT FOR APPROVED SUPPLIERS OF JUNCTION CABINET. ALTERNATIVE DESIGNS MAY BE SUBMITTED FOR APPROVAL.
  - CABINET SHALL BE ANCHORED TO THE FOUNDATION.
  - ComEd WILL FURNISH AND INSTALL CABLE AND LUGS BETWEEN JUNCTION CABINET BUS AND TRANSFORMER SECONDARY TERMINALS.
  - CUSTOMER SHALL NOT CONNECT THEIR CABLES TO BUS IN AREAS DESIGNATED AS ComEd POSITIONS.
  - BUS BAR SHOWN CAN ACCOMMODATE A MAXIMUM OF 20 CABLES PER PHASE FROM CUSTOMER AND 10 CABLES PER PHASE FROM ComEd TRANSFORMER.
  - CONSULT SPILL PREVENTION, CONTROL AND COUNTERMEASURES (SPCC) PROGRAM OR ENVIRONMENTAL SERVICES IF TOTAL OIL CAPACITY EQUAL TO OR EXCEEDING 1320 GALLONS EXISTS OR IS PLANNED AT ESS SITE.
  - FOR TRANSFORMER CLEARANCES REFER TO STANDARDS C5284, C5285, AND C7500.

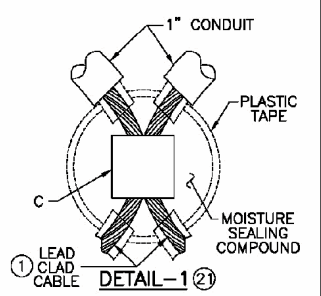

© Notice: The information contained on this page is the sole property of EXELON and is to be used only in conjunction with electric service provided by EXELON.

**Exelon** SYSTEM STANDARD  
 Energy Delivery

**NOTE TO DESIGNER**

THIS BASE SHEET SHOWS TYPICAL CONSTRUCTION BUT IT IS NOT A STANDARD DRAWING. IT REQUIRES COMPLETION BY THE DESIGNER PRIOR TO INSERTION INTO A CONTRACT. MICROSTATION FILES AND THE "CADD STANDARDS MANUAL" ARE AVAILABLE ON THE ILLINOIS TOLLWAY WEBSITE. THE DESIGNER SHALL ACCEPT THE RESPONSIBILITY OF THE DESIGN OF THIS SHEET UPON ITS COMPLETION AND INSERTION INTO A CONTRACT. ALL "NOTE TO DESIGNER" BOXES SHALL BE REMOVED BY THE DESIGNER PRIOR TO INSERTION OF THE SHEET INTO THE PLAN SET.

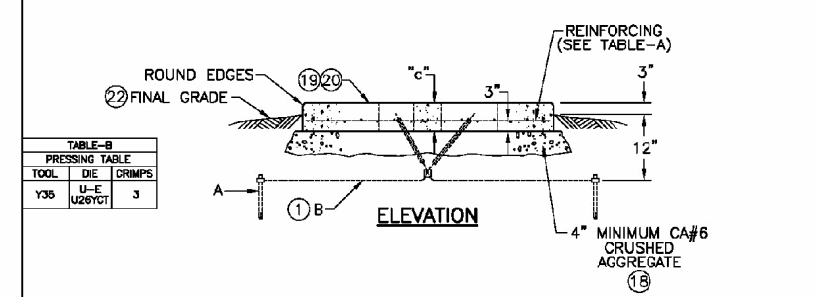
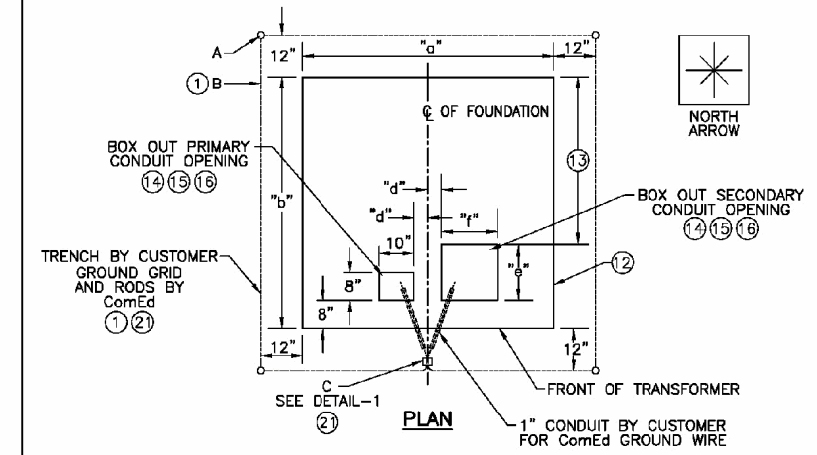

**TABLE-A**  
**SECONDARY CONDUIT FORMATIONS**

KVA	MIN SEC VOLTAGE		DIMENSIONS						3.5"	MAX NO. (23)	4"	MAX NO. (23)	REINFORCING (BARS BOTH WAYS)	ESTIMATING DATA	
	MIN	MAX	a	b	c	d	e	f						REINFORCING BARS (FT)	CONCRETE (CU YD)
J	45	225	208/120	6'-0"	5'-8"	6"	4"	14"	14"	4	4	#3 BARS 5" C.C.	150	.54	
C	112.5	300	208/120	6'-0"	5'-8"	6"	4"	14"	18"	6	6	#3 BARS 5" C.C.	150	.53	
D	225	500	208/120	7'-0"	6'-8"	6"	4"	18"	18"	9	9	#3 BARS 4" C.C.	250	.74	
E	750	750	208/120	7'-0"	6'-8"	6"	4"	18"	26.5"	16	12	#4 BARS 6" C.C.	174	.68	
F	45	75	480/277	6'-0"	5'-8"	6"	4"	14"	14"	4	4	#2 BARS 4" C.C.	142	.39	
G	112.5	300	480/277	6'-0"	5'-8"	6"	4"	14"	18"	6	6	#3 BARS 5" C.C.	150	.53	
H	225	1000	480/277	6'-0"	7'-0"	7"	4"	18"	18"	9	9	#4 BARS 5" C.C.	260	.94	
J	1500	2500	480/277	6'-0"	6'-8"	6"	4"	18"	26.5"	16	12	#4 BARS 5" C.C.	330	1.64	
K	500	750	4kV	7'-0"	6'-0"	6"	10"	8"	10"	2	2	#4 BARS 5" C.C.	196	.70	
L	1000	2500	4kV	8'-0"	8'-0"	8"	14"	14"	4	4	4	#4 BARS 5" C.C.	282	1.51	

© Notice: The information contained on this page is the sole property of EXELON and is to be used only in conjunction with electric service provided by EXELON.

**Exelon** SYSTEM STANDARD  
 Energy Delivery

**COMED TRANSFORMER PAD DETAIL**

VERSION:	BASE SHEET:	SHEET:
2021-03	M-BUS-2535	1 OF 1

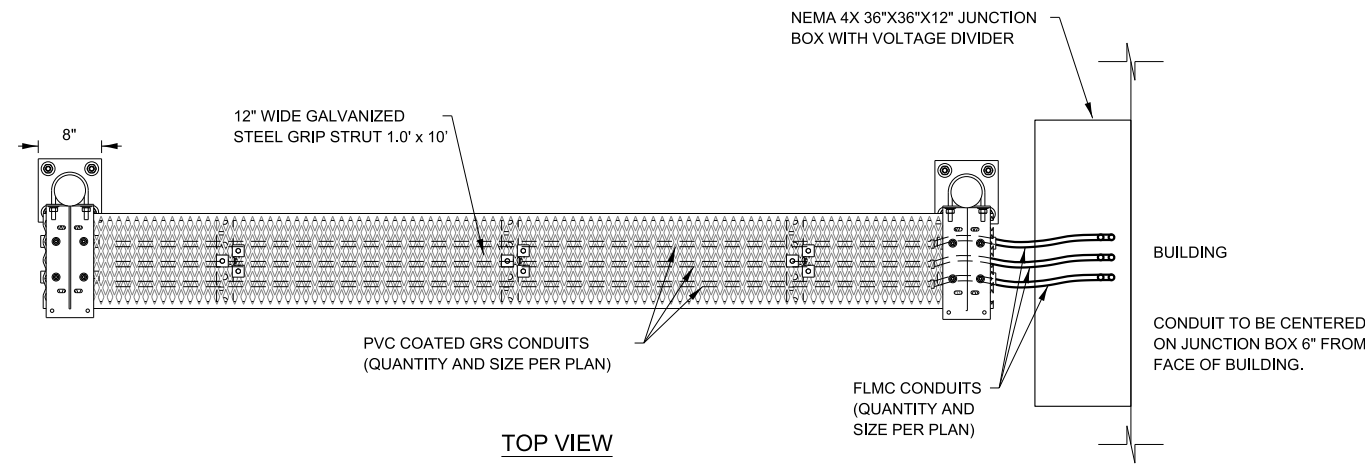

TOP VIEW

NOTES:

1. INSTALL CONDUIT TRAY PER MANUFACTURERS RECOMMENDATIONS.
2. SECURE CONDUIT TO CABLE TRAY.

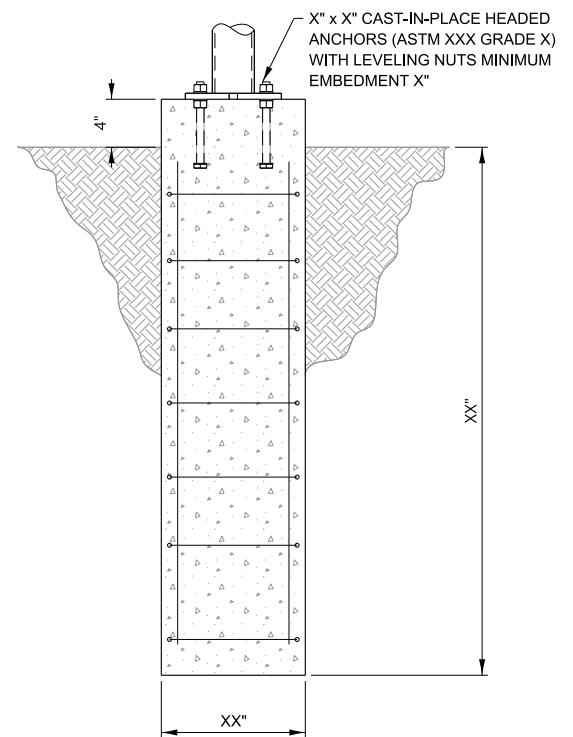

HSS COLUMN FOUNDATION

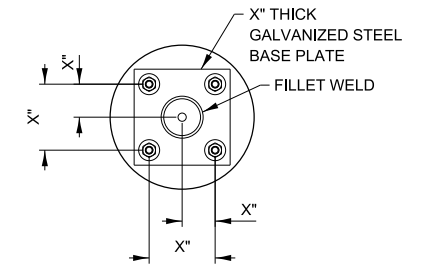

BASE PLATE LAYOUT

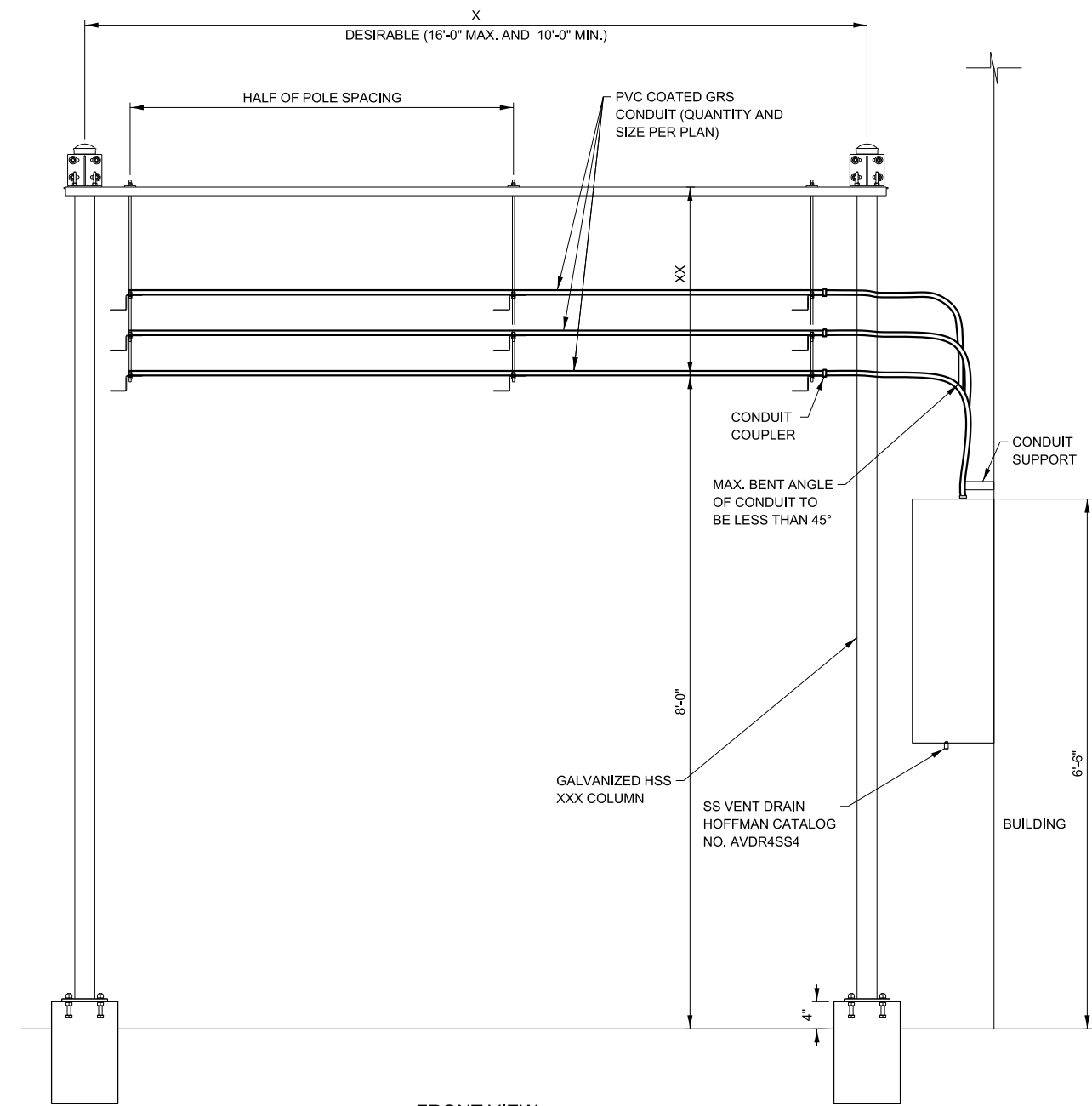

FRONT VIEW

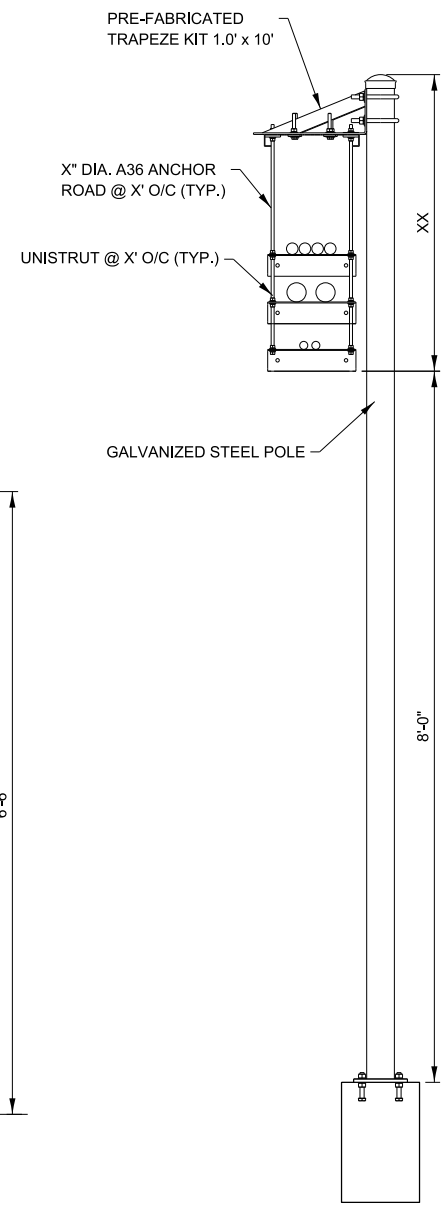

SIDE VIEW

NOTE TO DESIGNER  
 THE NUMBER AND SIZE OF CONDUIT AND THE NUMBER OF TRAYS TO BE DETERMINED BY DSE.

NOTE TO DESIGNER  
 ALL VALUES DESIGNATED "X" ARE REQUIRED AND SHALL BE PROVIDED BY THE DESIGNER. HSS COLUMN SECTION, FOUNDATION SIZE, AND REINFORCEMENT TO BE DETERMINED AND SHOWN BY DESIGNER.

NOTE TO DESIGNER  
 THIS BASE SHEET SHOWS TYPICAL CONSTRUCTION BUT IT IS NOT A STANDARD DRAWING. IT REQUIRES COMPLETION BY THE DESIGNER PRIOR TO INSERTION INTO A CONTRACT. MICROSTATION FILES AND THE "CADD STANDARDS MANUAL" ARE AVAILABLE ON THE ILLINOIS TOLLWAY WEBSITE. THE DESIGNER SHALL ACCEPT THE RESPONSIBILITY OF THE DESIGN OF THIS SHEET UPON ITS COMPLETION AND INSERTION INTO A CONTRACT. ALL "NOTE TO DESIGNER" BOXES SHALL BE REMOVED BY THE DESIGNER PRIOR TO INSERTION OF THE SHEET INTO THE PLAN SET.



OVERHEAD CONDUIT TRAY

**GENERAL NOTES:**

1. CONTRACTOR SHALL VERIFY ALL DIMENSIONS AND ELEVATION ON THE PLANS PRIOR TO CONSTRUCTION.
2. ALL MANUFACTURED ITEMS SHALL BE INSTALLED AND USED IN ACCORDANCE WITH MANUFACTURER'S GUIDELINES.

**DESIGN SPECIFICATIONS:**

1. ILLINOIS TOLLWAY STRUCTURE DESIGN MANUAL, LATEST EDITION.
2. AASHTO LRFD SPECIFICATION FOR STRUCTURAL SUPPORTS FOR HIGHWAY SIGNS LUMINARIES AND TRAFFIC SIGNALS, LATEST EDITION WITH CURRENT INTERIMS.
3. AASHTO LRFD BRIDGE DESIGN SPECIFICATION, LATEST EDITION.
4. ILLINOIS DEPARTMENT OF TRANSPORTATION BRIDGE MANUAL, LATEST EDITION.
5. ILLINOIS TOLLWAY GEOTECHNICAL ENGINEER MANUAL, LATEST EDITION.

**DESIGN LOADING:**

**WIND LOAD CRITERIA:**

BASIC WIND SPEED:	120 M.P.H.
G:	1.14
I <sub>F</sub> (FATIGUE IMPORTANCE FACTOR):	1.0
KZ:	1.0
WIND PRESSURE ON STRUCTURAL AND NON STRUCTURAL COMPONENTS:	62 P.S.F.
ICE LOAD (APPLIED WITH A FACTOR OF 1 FOR STRENGTH I ONLY):	3.0 P.S.F.

**EQUIPMENT LOADS:**

CONDUIT LOAD:	XXX P.L.F.
MAXIMUM NUMBER OF CONDUITS:	X

**DESIGN STRESSES FOR REINFORCED CONCRETE:**

f <sub>c</sub> (COMPRESSIVE STRENGTH OF CLASS DS CONCRETE):	4,000 P.S.I
f <sub>y</sub> (YIELD STRENGTH OF GRADE 60 REINFORCEMENT BARS):	60,000 P.S.I

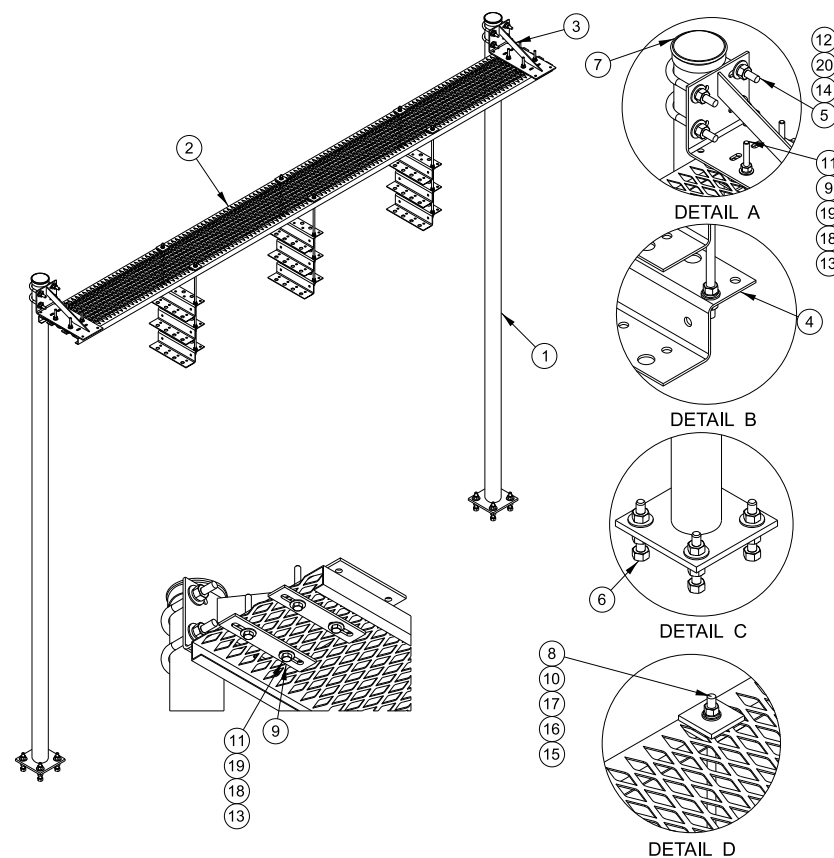

PARTS LIST		
ITEM	PART NO.	PART DESCRIPTION
1	X-SP126	BASE SHOE PLATE PIPE COLUMN
2	GRS12	12" WIDE GRIP STRUT
3	HH12	12" CANTILEVER WELDMENT
4	ZB12	1/2" MILL PLATE (F <sub>y</sub> =35 Ksi Min)
5	X-UB1358	XX" x XX" x XX" x XX" U-BOLT (HDG.)
6	SWA585	XX" x XX" STAINLESS WEDGE ANCHOR
7	PC312	XX" FENCE POST CAP
8	SS38R-18	XX" x XX" THREADED ROD (STAINLESS STEEL)
9	SPLICE	SPLICE FOR GRIP STRUT
10	SQW38	XX" SQUARE WASHER (GALV.)
11	G3803	XX" x 3" HDG HEX BOLT GR5
12	G12NUT	XX" HDG HEAVY 2H HEX NUT
13	G38NUT	XX" HDG HEAVY 2H HEX NUT
14	G12FW	XX" HDG USS FLATWASHER
15	SS38NUT	XX" SS HEX NUT
16	SS38LW	XX" SS LOCKWASHER
17	SS38FW	XX" STAINLESS FLATWASHER
18	G38LW	XX" HDG LOCKWASHER
19	G38FW	XX" HDG USS FLATWASHER
20	G12LW	XX" HDG LOCKWASHER

**12" GRIP-SPAN ICE BRIDGE KITS  
WITH 2-LEVEL Z-BRACKET TRAPEZE  
BASE SHOE**

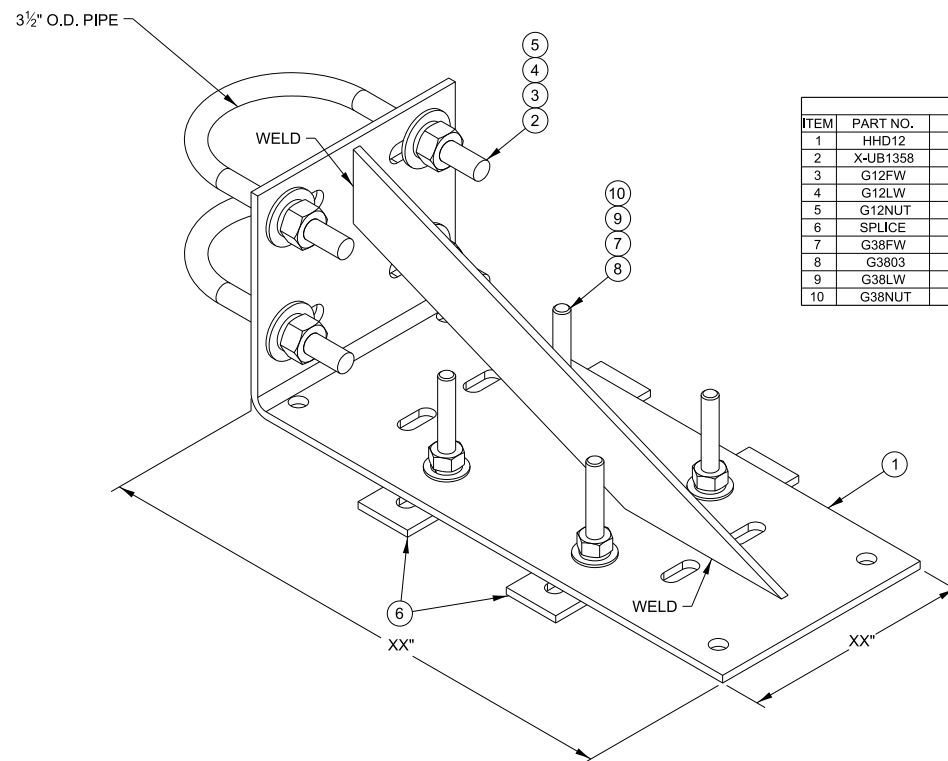

PARTS LIST		
ITEM	PART NO.	PART DESCRIPTION
1	HH12	12" CANTILEVER WELDMENT
2	X-UB1358	XX" x XX" x XX" x XX" U-BOLT (HDG.)
3	G12FW	XX" HDG USS FLATWASHER
4	G12LW	XX" HDG LOCKWASHER
5	G12NUT	XX" HDG HEAVY 2H HEX NUT
6	SPLICE	SPLICE FOR GRIP STRUT
7	G38FW	XX" HDG USS FLATWASHER
8	G3803	XX" x XX" HDG HEX BOLT GR5
9	G38LW	XX" HDG LOCKWASHER
10	G38NUT	XX" HDG HEAVY 2H HEX NUT

**12" COMPLETE  
CANTILEVER KIT**

NOTE TO DESIGNER  
THICKNESS OF PLATE TO BE SPECIFIED BY DSE.

**NOTES:**

1. JUNCTION BOX PLACEMENT AND EXACT CONDUIT PATHS WILL VARY BY PLAZA LAYOUT AND ARE SHOWN DIAGRAMATICALLY FOR CLARITY.
2. DIRECT BURY CONDUITS SHALL BE PLACED IN TRENCH AS FLAT AND STRAIGHT AS POSSIBLE.
3. FOR PLAZAS WHERE JUNCTION BOX LAYOUT REQUIRES CROSSING OF OTHER DUCTS, THE LARGER/LARGEST DUCT(S) SHALL ALWAYS BE PLACED ON THE BOTTOM.
4. NO DUCT MAY CROSS ANY OTHER DUCT MORE THAN ONE TIME WITHOUT WRITTEN APPROVAL FROM TOLLWAY AND THE ENGINEER.
5. ALL HDPE INNERDUCT (SDR 11) MUST BE CONTINUOUS AND UNSPLICED FROM END TO END (JUNCTION BOX TO JUNCTION BOX), ENSURE SUFFICIENT SLACK REMAINS TO PREVENT DUCT FROM RECEEDING INTO SLEEVE AFTER PLACEMENT.
6. SPACERS SHALL BE USED FOR THE DUCT BANK. 5' SEPARATION SHALL BE USED. SEE SPACER DETAILS.

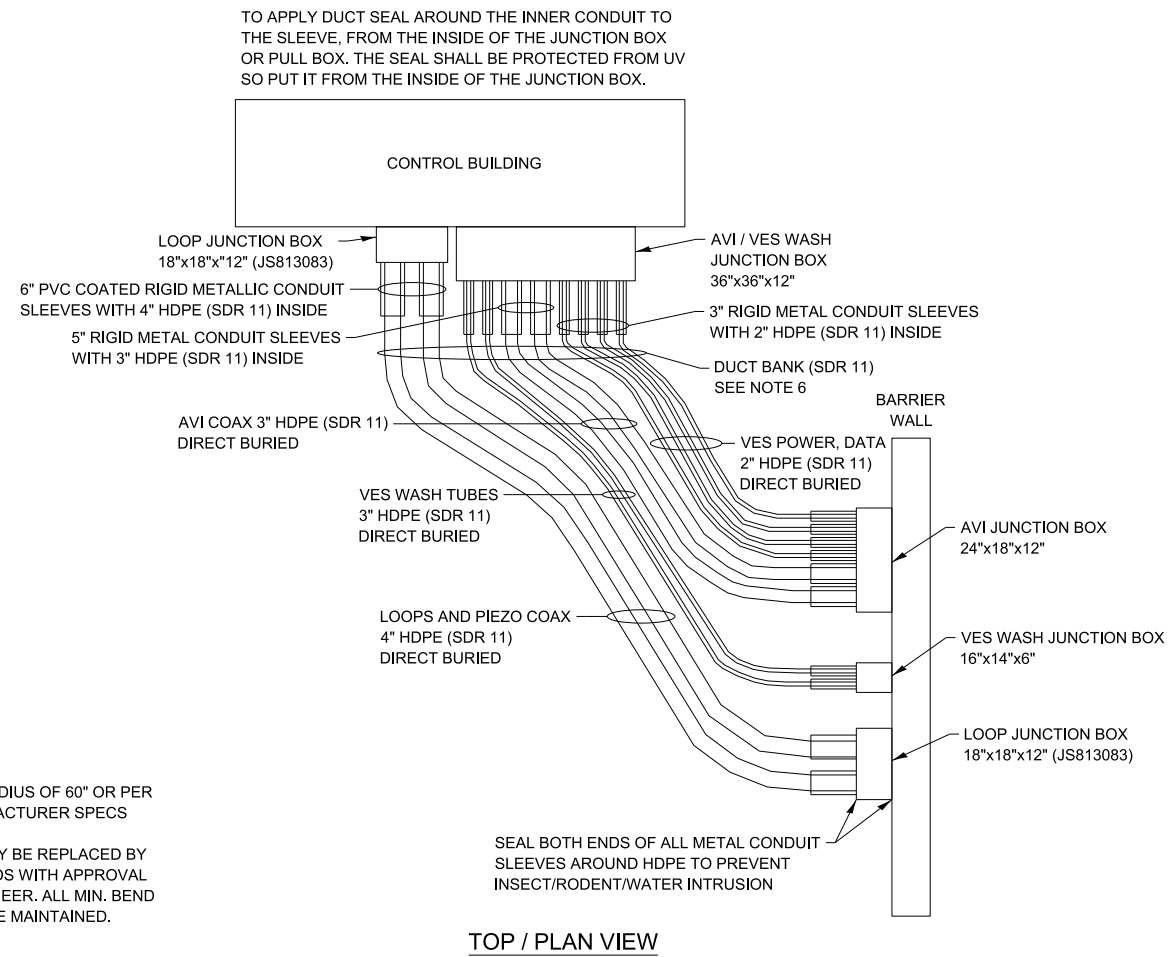
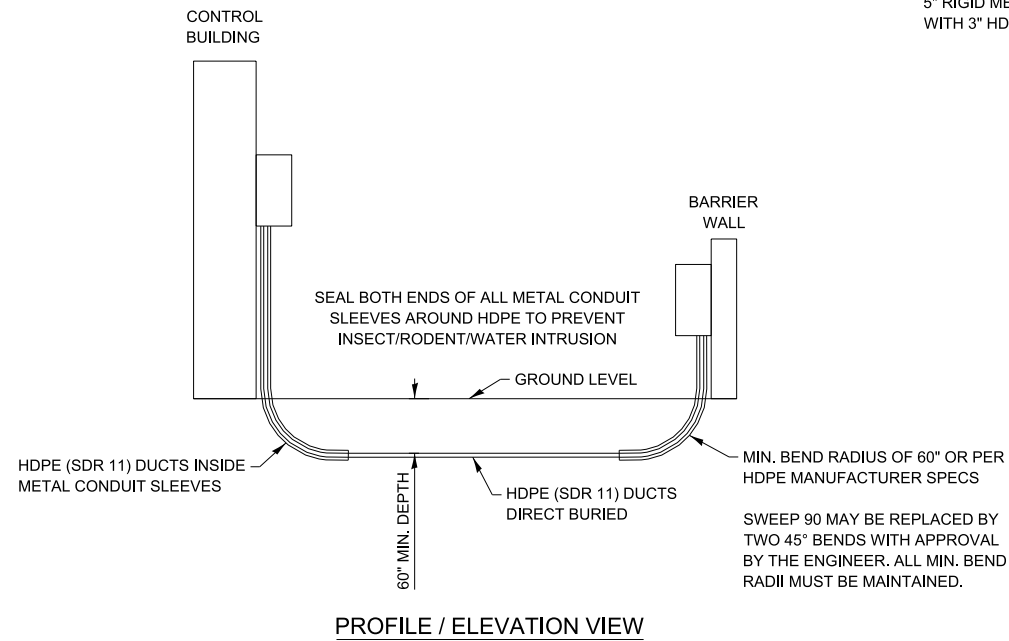

**UNDERGROUND TOLLING  
CONDUIT DETAIL**

CONTROL BUILDING

PUNCHING THE HOLES AT THE BOTTOM OF THE JUNCTION BOX SHALL BE DONE WITH THE INTENT OF KEEPING THE BOX'S STRUCTURAL INTEGRITY

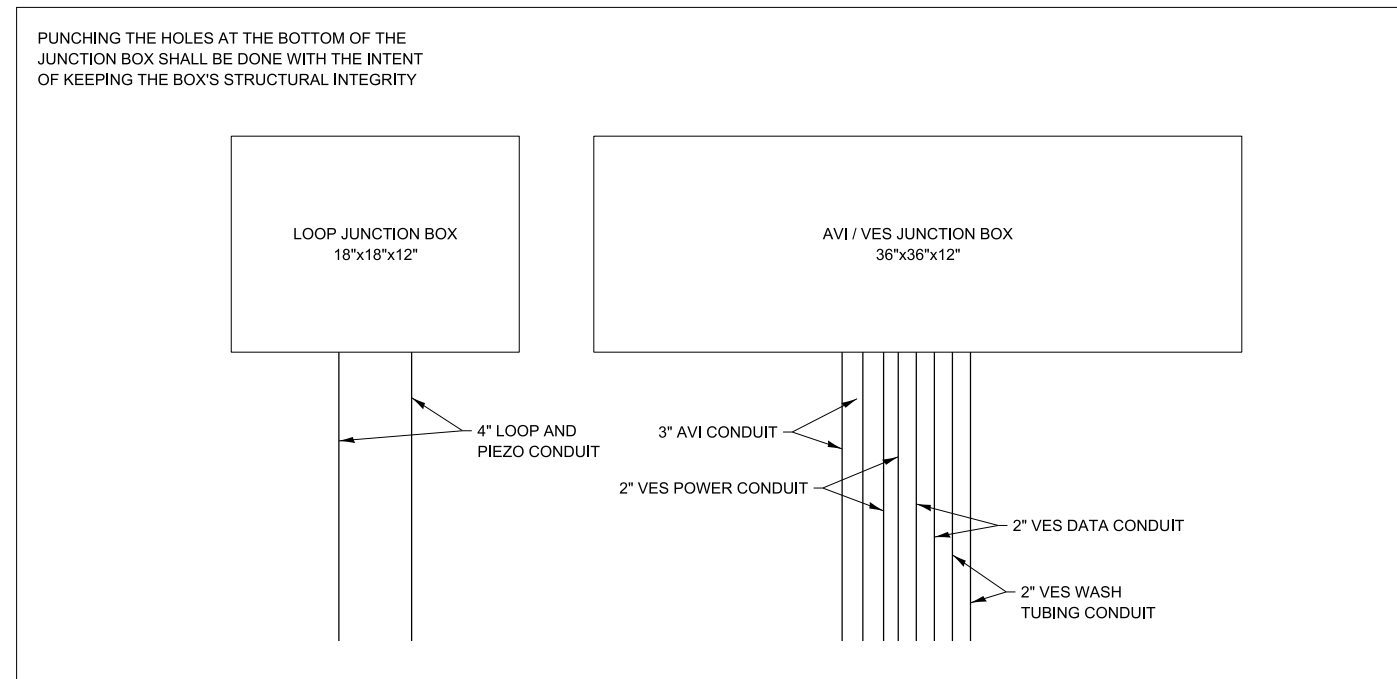

FOR VES WASH TUBING NO SPLICING WOULD BE ALLOWED. THE TUBE SHALL BE CONTINUOUS FROM THE VES WASH CABINET ALL THE WAY TO THE VES CAMERA IN "ONE" PIECE.

NOTES:

1. ALL CONDUITS ABOVE GROUND ARE PVC COATED RGS WITH SDR 11 HDPE CONDUIT
2. SEE DUCT PACKAGE AND SLEEVE DETAILS
3. SLEEVES AND SDR 11 WITHIN THE SLEEVES ARE DETAILED ON DUCT PACKAGE AND SLEEVE DETAILS

CONTROL BUILDING AVI / VES / LOOP  
JUNCTION BOX DETAILS



CONTROL BUILDING  
JUNCTION BOX DETAIL FOR  
UNDERGROUND CONDUIT

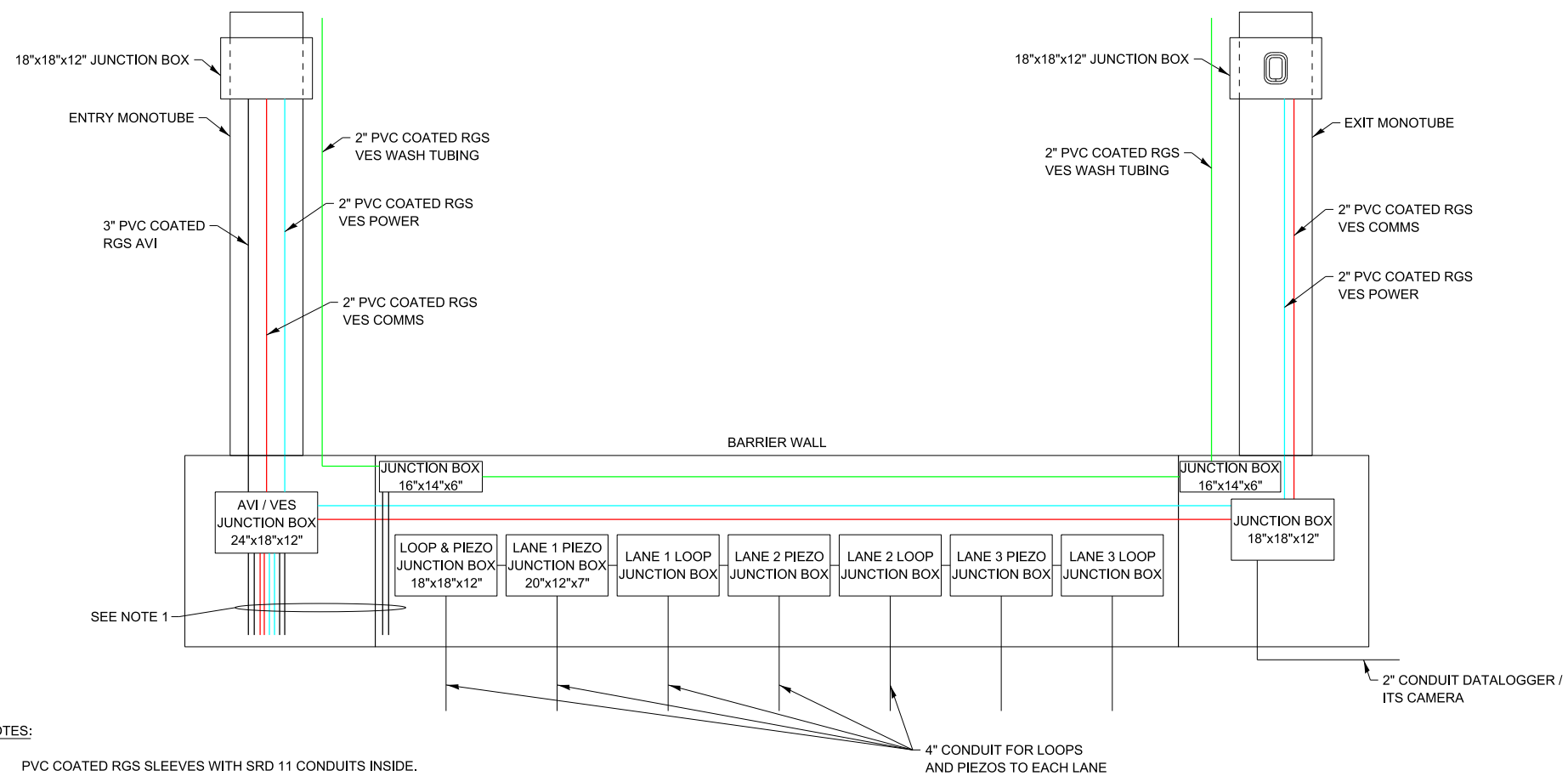

**NOTES:**

1. PVC COATED RGS SLEEVES WITH SRD 11 CONDUITS INSIDE. CONDUIT SIZES SHOWN ON DETAILS.

**UNDERGROUND CONDUIT  
ELEVATION INSTALLATION DETAIL**



**UNDERGROUND CONDUIT  
ELEVATION INSTALLATION  
DETAIL**

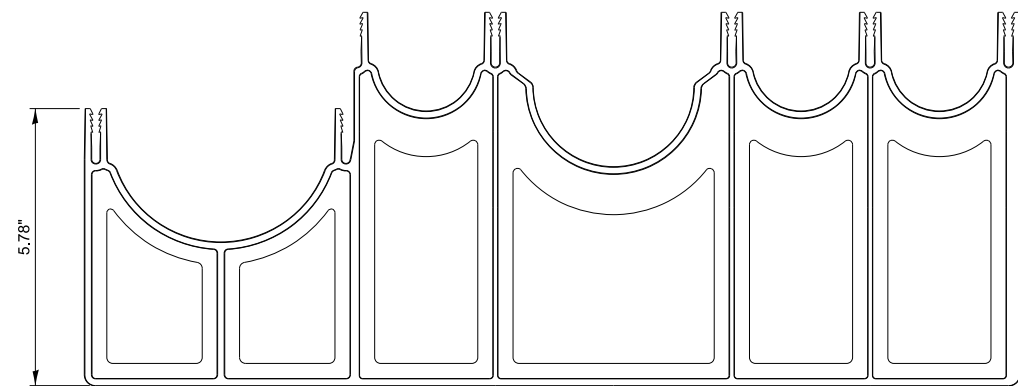
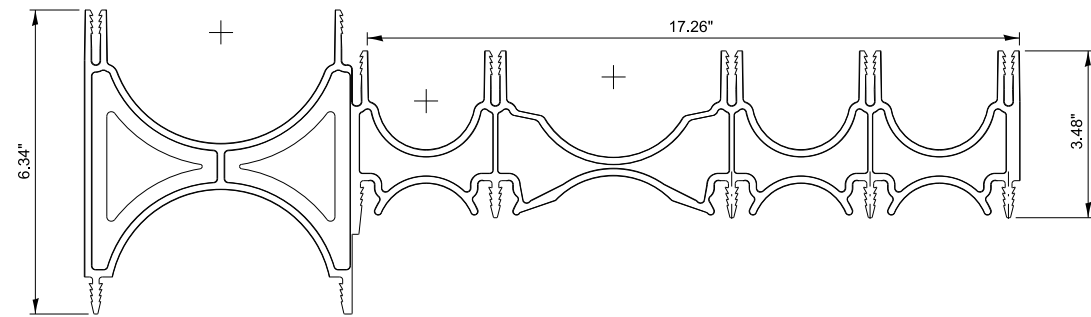
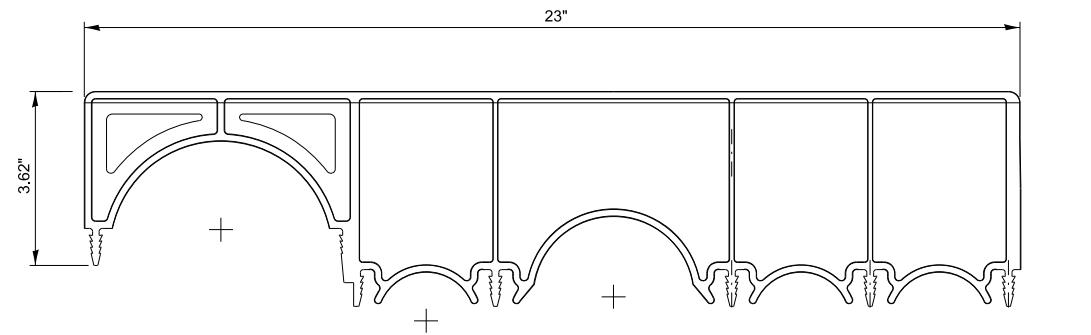
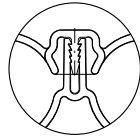

INTERLOCKING CONDUIT SPACER SYSTEM

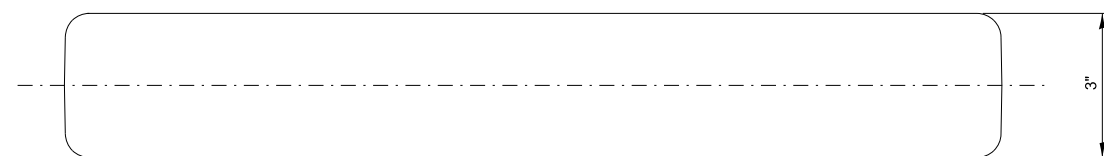

BOTTOM VIEW

NOTES:

1. THIS IS A REPRESENTATION ONLY, THE DSE HAS TO ADAPT THE NUMBER OF CONDUIT PER THE DESIGN.
2. CONTROLLED LOW STRENGTH MATERIAL (CLSM) SHALL BE PLACED A MINIMUM OF 3" TO THE SIDE OF AND ABOVE THE INTERLOCKING CONDUIT SPACER SYSTEM.

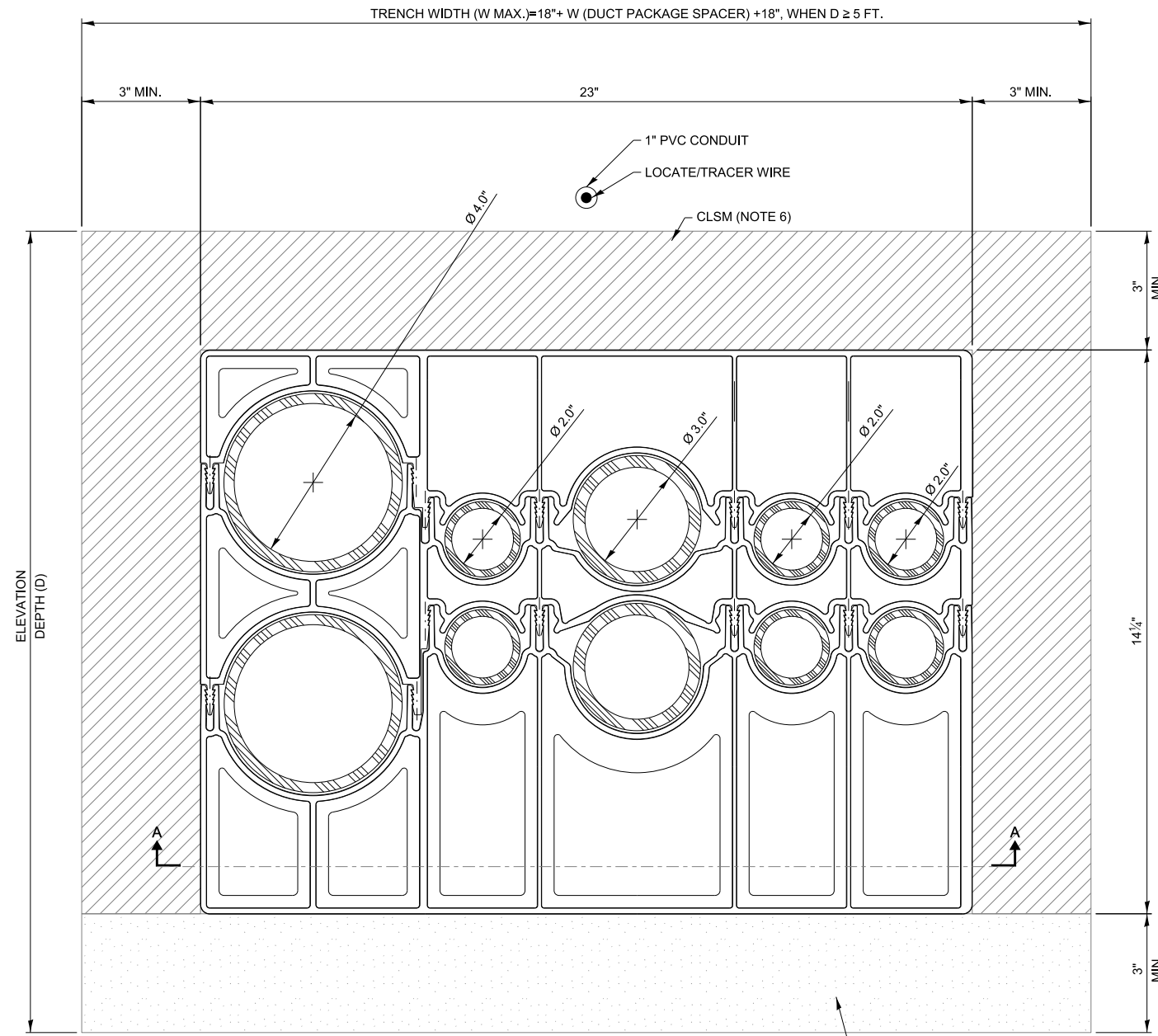

FRONT VIEW



SECTION A-A

NOTES:

1. USE ONE SOLID PIECE SPACER (UNDERGROUND DEVICES BS1366SS OR APPROVED EQUAL) AT 5 FOOT INTERVALS FOR THE FULL LENGTH OF THE DUCT BANK.
2. WHEN PLACING CLSM AROUND CONDUITS, ADJUST THE DELIVERY CHUTE SO THE FALL OF THE CONCRETE IS MINIMAL. POUR THE CONCRETE SLOWLY AND DISTRIBUTE IT EVENLY SO AS NOT TO DISLodge THE SPACERS.
3. THE DUCT BANK MUST BE HELD IN PLACE AT INSTALLED DEPTH BELOW SUBGRADE DURING AND IMMEDIATELY AFTER THE CONCRETE POUR TO PREVENT CONDUIT FLOTATION.
4. CONTROLLED LOW STRENGTH MATERIAL (CLSM) SHALL BE PLACED A MINIMUM OF 3 INCHES ON EACH SIDE OF THE CONDUIT ASSEMBLY, AND ABOVE THE INTERLOCKING CONDUIT SPACER SYSTEM.

DUCT BANK SPACER DETAILS



DUCT SPACER DETAILS

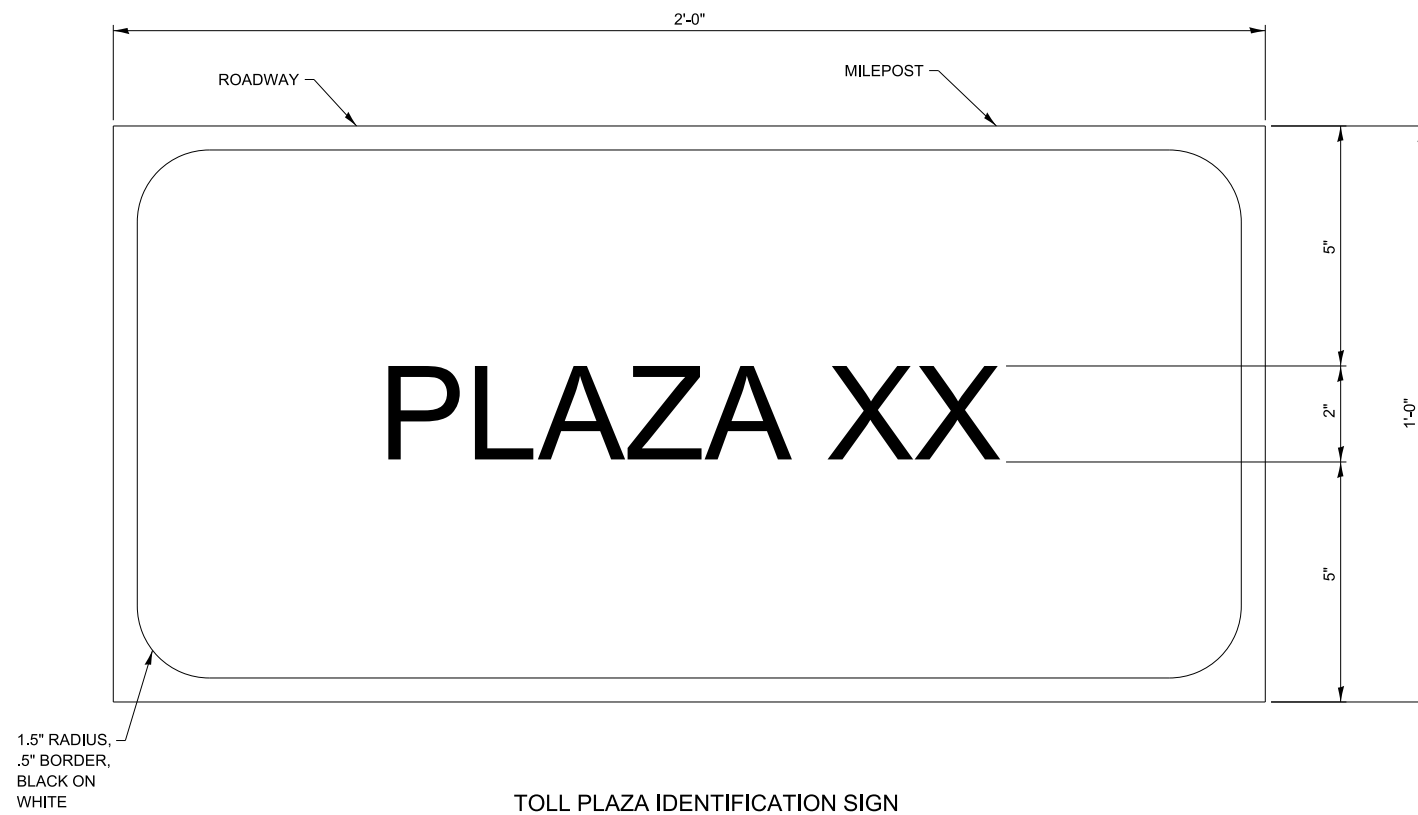

**NOTES:**

1. IDENTIFICATION SIGN MATERIAL SHALL MEET THE REQUIREMENTS OF ARTICLE 720.02 OF THE STANDARD SPECIFICATIONS.
2. IDENTIFICATION SIGNS SHALL BE MOUNTED ONTO THE BUILDING USING BOLTS AND WASHERS ACCORDING TO ARTICLE 720.04 OF THE STANDARD SPECIFICATIONS.



**TOLL PLAZA  
IDENTIFICATION SIGN**

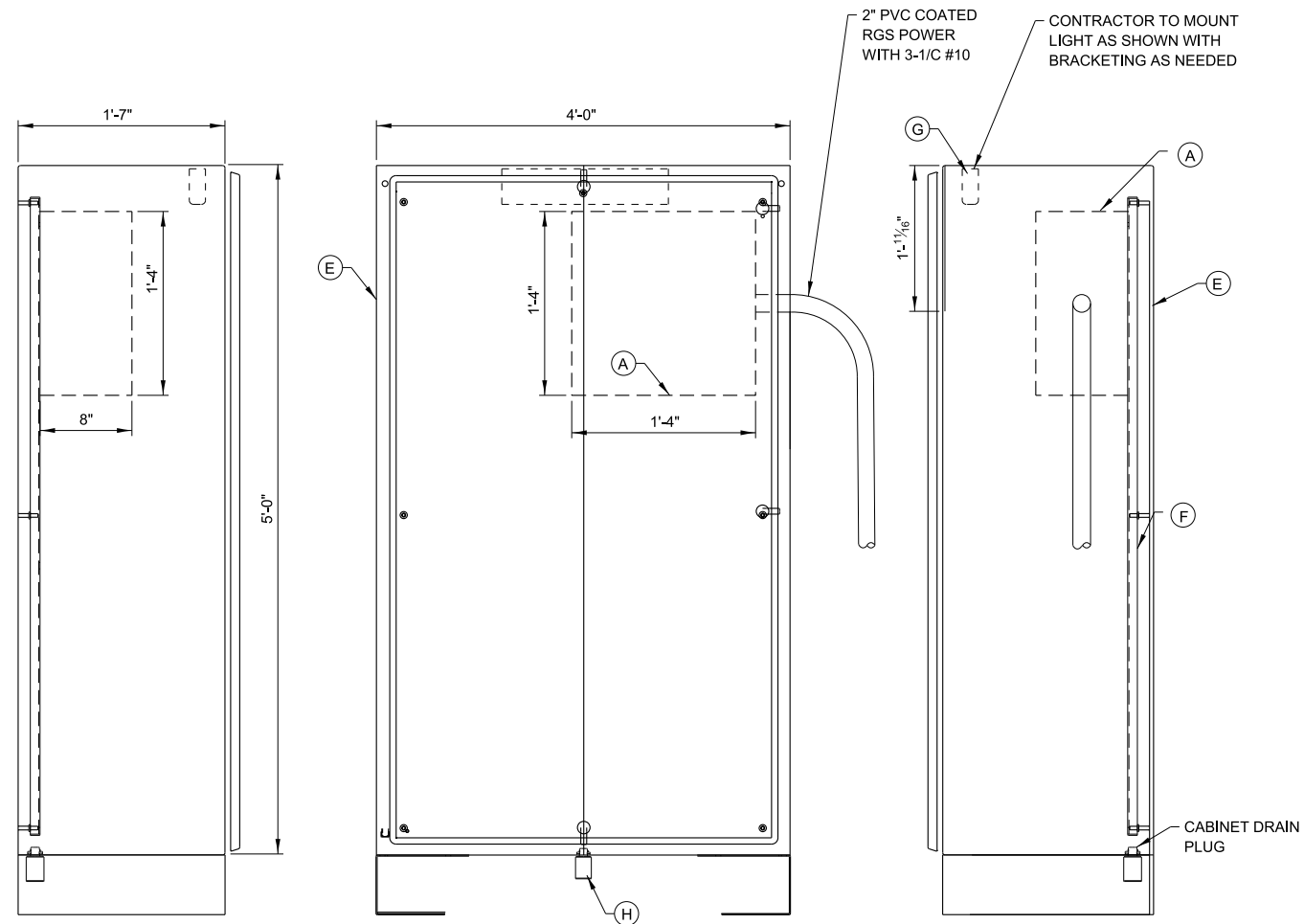

LEFT SIDE VIEW

MAIN ENCLOSURE

SCALE: 1 1/2"=1'-0"

RIGHT SIDE VIEW

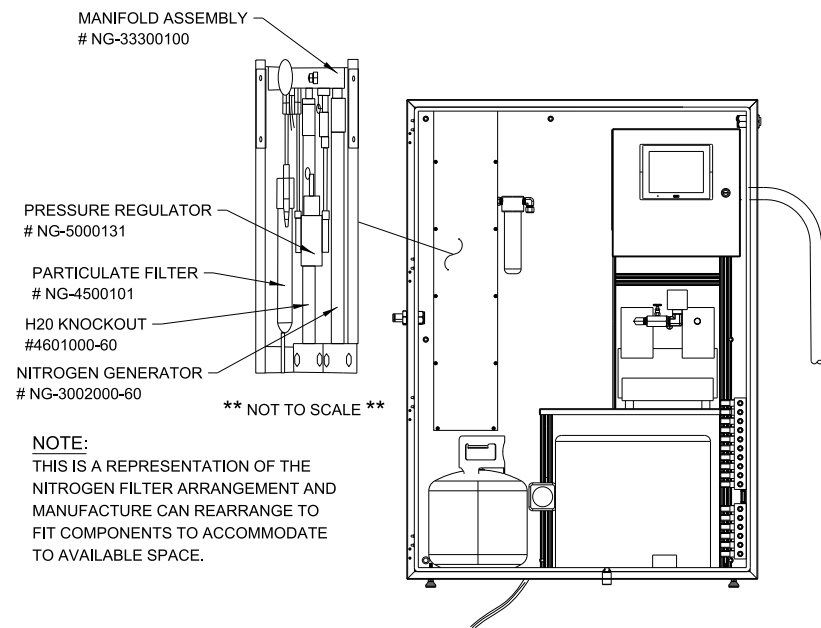

\*\*\*FOR COMPLETE ASSEMBLY USE ECD # NS-GEN-SY-Y-0300 (OR APPROVED EQUAL)\*\*\*

VES WASH SYSTEM SINGLE CABINET  
INSIDE DETAILS  
NOT TO SCALE

BILL OF MATERIALS COMPONENTS (OR APPROVED EQUAL)			
MARK NO.	QTY.	SPARE	DESCRIPTION
(A)	1		NEMA 4 STAINLESS STEEL ENCLOSURE - 16"H X 16"W X 8"D (HOFFMAN) INDOOR INSTALLATION: NEMA-1 HAMMOND # HW603616SSHK OUTDOOR INSTALLATION: NEMA-3R HAMMOND # HWST603616SS
(B)	1		SUBPANEL FOR ENCLOSURE (HOFFMAN CATALOG No. CP3024)
(D)	1		GROUNDING BAR (HOFFMAN CATALOG No. PGS2K) (NOT ILLUSTRATED ON DRAWING)
(E)	1		NEMA 1 ENCLOSURE - 60"H X 48"W X 19"D (HOFFMAN CATALOG No. HN4FM604818S16) WITH MOUNTING BRACKETS (HOFFMAN CAT. No. CMFKSS) FOR OUTDOOR CABINET INSTALLATION; USE NEMA 4X HOFFMAN CABINET OF SAME DIMENSION. THE MANUFACTURER OF THE VES WASH CABINET WILL KNOW WHICH HOFFMAN CABINET MODEL TO USE.
(F)	1		SUBPANEL FOR NEMA 1 ENCLOSURE (HOFFMAN CATALOG No. A49P32N)
(G)	1		FLUORESCENT LIGHT FIXTURE FOR ENCLOSURE WITH 120VAC OUTLET (HOFFMAN CATALOG No. LF120V15) WITH DOOR SWITCH (HOFFMAN CATALOG No. ALFSWD)
(H)	1		SS VENT DRAIN HOFFMAN CATALOG No. AVDR4SS4

NOTES:

1. EXACT OPERATING PRESSURE TO BE DETERMINED.
2. FOR PRODUCT SUBSTITUTIONS SEE THE SPECIFICATIONS.
3. ALL CONDUITS, FITTINGS AND ENTRY POINTS INTO EACH OF THE ENCLOSURES SHALL BE PROPERLY SEALED WITH DUCT SEAL TO PREVENT MOISTURE ENTRY.
4. THIS DETAIL IS APPLICABLE TO VES WASH SYSTEM MAIN ENCLOSURE INSIDE THE BUILDINGS. FOR OUTSIDE INSTALLATION OF MAIN VES WASH SYSTEM ENCLOSURE, USE NEMA 4X ENCLOSURE - 60"H X 36"W X 16"D, NO. WS603616SS, & PAD LOCKING HANDLE KIT.

NOTE TO DESIGNER  
THIS BASE SHEET SHOWS TYPICAL CONSTRUCTION BUT IT IS NOT A STANDARD DRAWING. IT REQUIRES COMPLETION BY THE DESIGNER PRIOR TO INSERTION INTO A CONTRACT. MICROSTATION FILES AND THE "CADD STANDARDS MANUAL" ARE AVAILABLE ON THE ILLINOIS TOLLWAY WEBSITE. THE DESIGNER SHALL ACCEPT THE RESPONSIBILITY OF THE DESIGN OF THIS SHEET UPON ITS COMPLETION AND INSERTION INTO A CONTRACT. ALL "NOTE TO DESIGNER" BOXES SHALL BE REMOVED BY THE DESIGNER PRIOR TO INSERTION OF THE SHEET INTO THE PLAN SET.



VES WASH SYSTEM SINGLE CABINET DETAIL

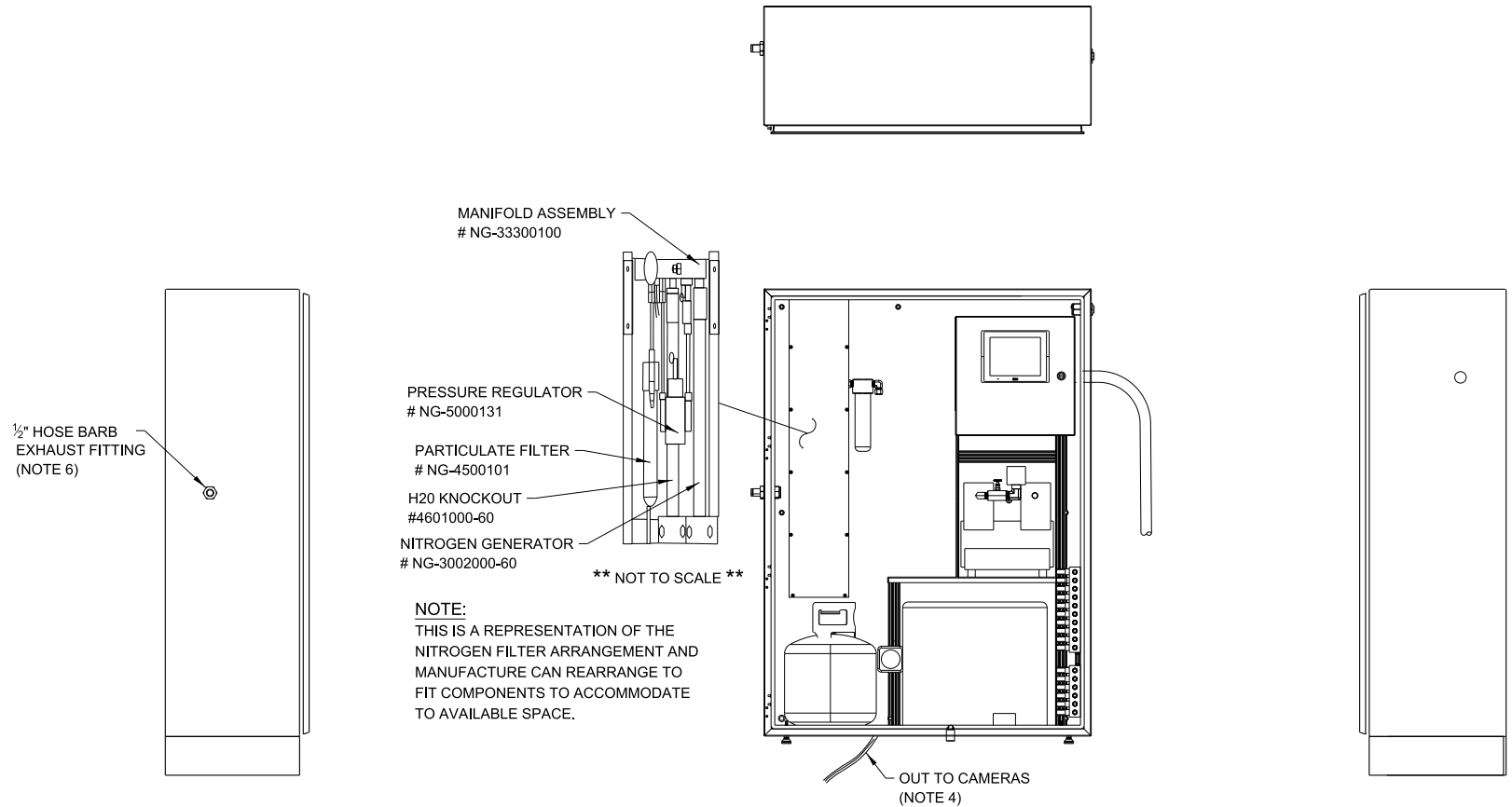

**VES WASH SYSTEM SINGLE CABINET  
INSIDE DETAILS**

\*\*\*FOR COMPLETE ASSEMBLY USE ECD # NS-GEN-SY-Y-0300 (OR APPROVED EQUAL)\*\*\*  
NOT TO SCALE

**NOTES:**

1. 20A ,115VAC SERVICE REQUIRED.
2. WILL REQUIRE: LOCATION, IP ADDRESS AND LANE CONFIGURATION.
3. PNEUMATIC FITTINGS TO BE BRASS IN CONSTRUCTION AND MEET SOCIETY OF AUTOMOTIVE ENGINEERS (SAE) SPECIFICATIONS.
4. THE 3/8" NYLON TUBING MAY HAVE TO BE LONGER THAN 100'. TUBING MUST RUN CONTINUOUS FROM THE MANIFOLD VALVES IN THE VES CABINET TO THE CAMERA NOZZLE, WITHOUT ANY INTERMEDIATE SPLICES. CONTRACTOR TO DETERMINE THE ACTUAL LENGTH OF THE TUBING REQUIRED FOR EACH OF THE VES CAMERAS AT THE SITE. THE NYLON TUBES ARE INSIDE OF RGS CONDUIT. CONTRACTOR SHALL KEEP A 1' SLACK INSIDE THE VES WASH ENCLOSURE FOR EACH OF THE VES WASH TUBING WHEN CONNECTED TO THE SOLENOID DISTRIBUTION VALVE.
5. ALL CONDUIT FITTINGS AND ENTRY POINTS INTO THE ENCLOSURE SHALL BE PROPERLY SEALED WITH DUCT SEAL TO PREVENT MOISTURE ENTRY.
6. EXHAUST TO FREE AIR.
7. THE VES WASH SYSTEM WITH NITROGEN GENERATOR IS PRODUCED BY ECD COMPANY WITH THE MODEL NUMBER: NS-GEN-SY-Y-0300, AS ASSIGNED BY ECD (OR APPROVED EQUAL MODEL BY THE ILLINOIS TOLLWAY BUSINESS SYSTEMS). CONTRACTOR TO FABRICATE THE VES WASH SINGLE CABINET SYSTEM WITH NITROGEN GENERATOR IN COORDINATION WITH THE SYSTEM VENDOR, TO PROVIDE A COMPLETE FUNCTIONAL SYSTEM, AS SPECIFIED IN THE CONTRACT DOCUMENTS. THE CONTRACTOR SHALL VERIFY WITH THE VENDOR THAT ALL REQUIRED SYSTEM COMPONENTS FIT IN THE MAIN VES WASH CABINET AS SHOWN, IN COMPLIANCE WITH APPLICABLE CODES.
8. CONTRACTOR SHALL VERIFY THE NUMBER OF VES CAMERAS AT EACH INSTALLATION SITE, AS SHOWN ON THE PLANS, AND COORDINATE WITH THE SYSTEM VENDOR TO PROVISION THE VES WASH SYSTEM WITH THE REQUIRED NUMBER OF NITROGEN AND FLUID VALVES AT EACH INSTALLATION SITE.
9. OUTDOOR INSTALLATION WILL REQUIRE A 500W HEATER.

MATERIALS LIST			
PART NO.	DESCRIPTION	MANUAL	QUANTITY
NS-GEN-SY-Y-0300	COMPLETE ASSEMBLY	ECD	1
NS-SUB-SY-I-0100	NITROGEN GENERATOR	ECD	1
NG-ECD-00100	REPLACEMENT PARTICULATE FILTER	ECD	1
NG-ECD-00200	NITROGEN VALVE SYSTEM	ECD	1
NG-ECD-00201	LIQUID VALVE SYSTEM	ECD	1
NG-ECD-00300	LIQUID PUMP	ECD	1
NG-ECD-00314	LIQUID TANK	ECD	1
NG-ECD-01101	SYSTEM CONTROL	ECD	1
NG-ECD-00310	PNEUMATIC PUMP	ECD	1
NG-ECD-00311	NITROGEN TANK	ECD	1

**NOTE TO DESIGNER**

THIS BASE SHEET SHOWS TYPICAL CONSTRUCTION BUT IT IS NOT A STANDARD DRAWING. IT REQUIRES COMPLETION BY THE DESIGNER PRIOR TO INSERTION INTO A CONTRACT. MICROSTATION FILES AND THE "CADD STANDARDS MANUAL" ARE AVAILABLE ON THE ILLINOIS TOLLWAY WEBSITE. THE DESIGNER SHALL ACCEPT THE RESPONSIBILITY OF THE DESIGN OF THIS SHEET UPON ITS COMPLETION AND INSERTION INTO A CONTRACT. ALL "NOTE TO DESIGNER" BOXES SHALL BE REMOVED BY THE DESIGNER PRIOR TO INSERTION OF THE SHEET INTO THE PLAN SET.

**VES WASH SYSTEM PANEL  
DETAIL**

VERSION: 2026-03	BASE SHEET: M-BUS-2539	SHEET: 1 OF 1
---------------------	---------------------------	------------------

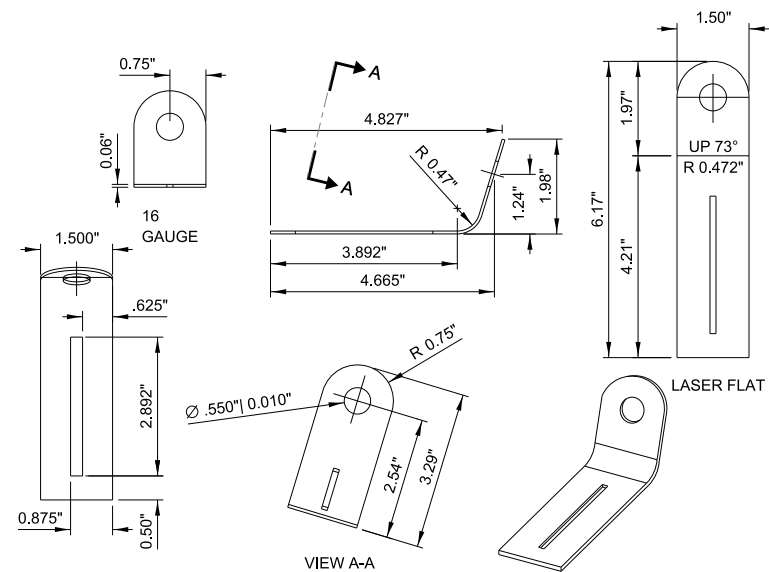

**VES CAMERA NOZZLE BRACKET DETAIL**  
NOT TO SCALE

BILL OF MATERIAL COMPONENTS (OR APPROVED EQUAL)			
MARK NO.	QTY.	SPARE	DESCRIPTION
(A)	AS REQUIRED PER CONTRACT	2 SPOOLS OF 150 FEET	SILICONE HOSE SLEEVE CONTINUOUS TUBING FROM VES WASH CABINET TO CAMERA. NO SPLICING ALLOWED. McMASTER-CARR CATALOG No. 7453K49
(B)	AS REQUIRED PER CONTRACT	3	SPRAY NOZZLE GRAINGER CATALOG No. 1MDH2
(C)	AS REQUIRED PER CONTRACT	3	MINIATURE CORROSION RESISTANT STRAIN RELIEF HUBBELL CATALOG No. SHC1021CR
(D)	AS REQUIRED PER CONTRACT	3	ADJUSTABLE MOUNTING STRAP McMASTER-CARR CATALOG No. 7572K12 (50 PER PACK)
(E)	AS REQUIRED PER CONTRACT	3	NOZZLE BULKHEAD FITTING (10 PACK) SMC FITTING CATALOG No. KQ2E07-35

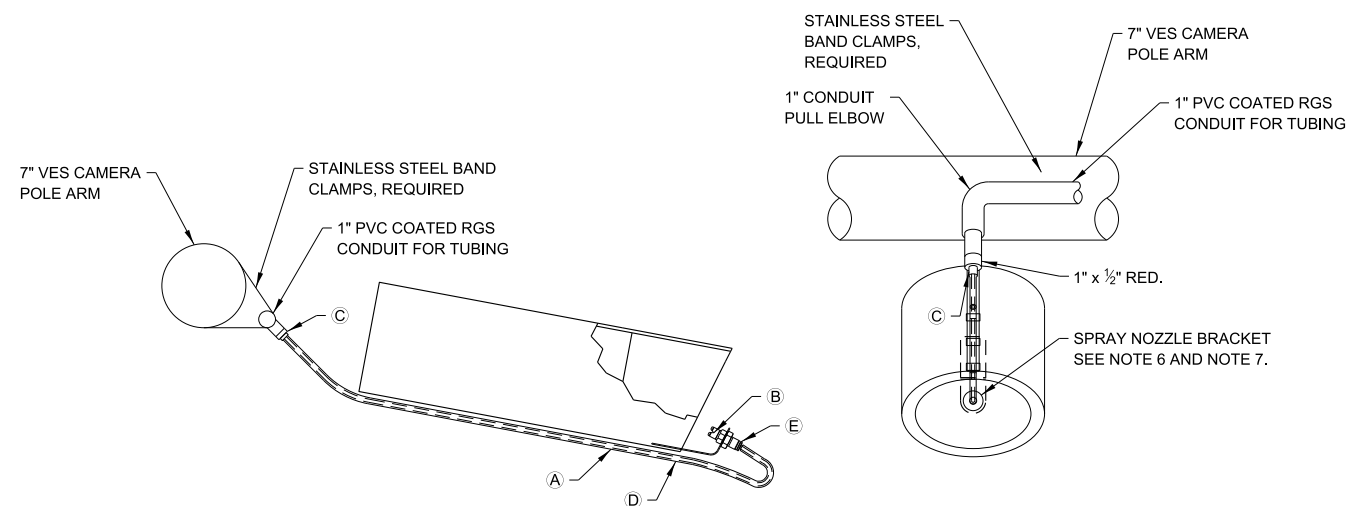

**NOZZLE DETAIL - VES CAMERA MONOTUBE**  
NOT TO SCALE

**NOTES:**

- CAMERA NOZZLE BRACKET SHALL BE FABRICATED USING 12 GA. STAINLESS STEEL. CONTRACTOR TO SUBMIT SHOP DRAWINGS FOR APPROVAL.
- CAMERA NOZZLE BRACKET SHALL BE ADJUSTABLE. STAINLESS STEEL NUT-BOLT COMBINATION SHALL BE USED FOR MOUNTING THE CAMERA NOZZLE BRACKET TO THE CAMERA LENS HOUSING. CONTRACTOR TO VERIFY THAT THE MOUNTING HARDWARE SECURELY HOLDS THE BRACKET BUT ALSO ALLOWS EASY ADJUSTMENT. CONTRACTOR SHALL SUBMIT INSTALLATION DRAWINGS CLEARLY IDENTIFYING PART NUMBERS USED FOR MOUNTING HARDWARE. INSTALLATION DRAWINGS SHALL ALSO INDICATE THE POSITION OF THE MOUNTING HARDWARE ON THE CAMERA NOZZLE BRACKET. THE INSTALLATION DRAWINGS SHALL BE APPROVED BY THE ILLINOIS TOLLWAY BEFORE INSTALLATION IN THE FIELD.

NOTE TO DESIGNER

THIS BASE SHEET SHOWS TYPICAL CONSTRUCTION BUT IT IS NOT A STANDARD DRAWING. IT REQUIRES COMPLETION BY THE DESIGNER PRIOR TO INSERTION INTO A CONTRACT. MICROSTATION FILES AND THE "CADD STANDARDS MANUAL" ARE AVAILABLE ON THE ILLINOIS TOLLWAY WEBSITE. THE DESIGNER SHALL ACCEPT THE RESPONSIBILITY OF THE DESIGN OF THIS SHEET UPON ITS COMPLETION AND INSERTION INTO A CONTRACT. ALL "NOTE TO DESIGNER" BOXES SHALL BE REMOVED BY THE DESIGNER PRIOR TO INSERTION OF THE SHEET INTO THE PLAN SET.

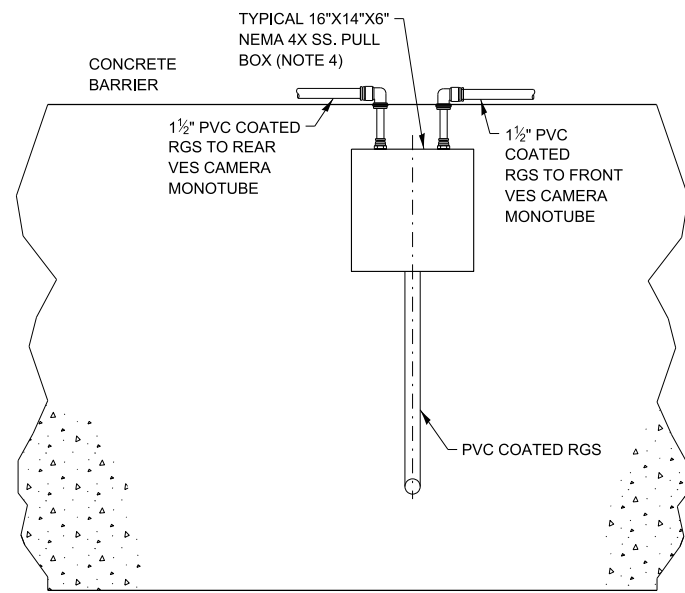

**PARTIAL SECTION A-A**  
NOT TO SCALE

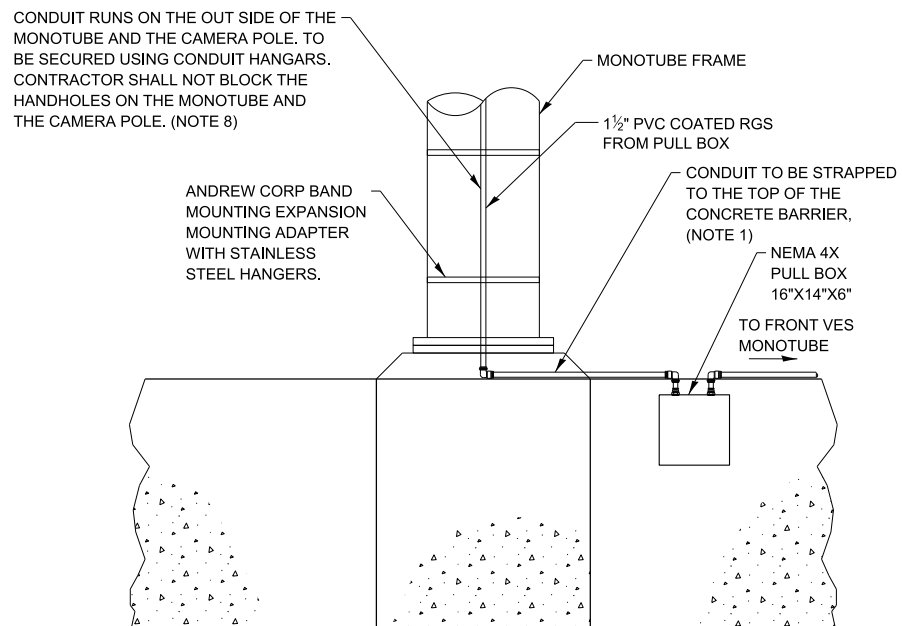

**COLLECTION STRUCTURE CONDUIT DETAIL**

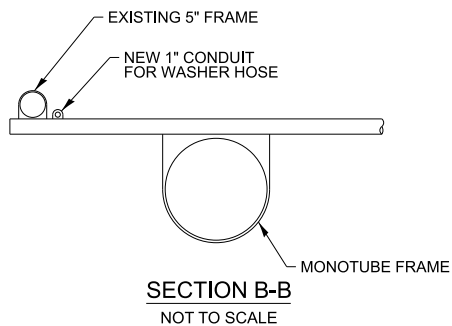

**SECTION B-B**  
NOT TO SCALE

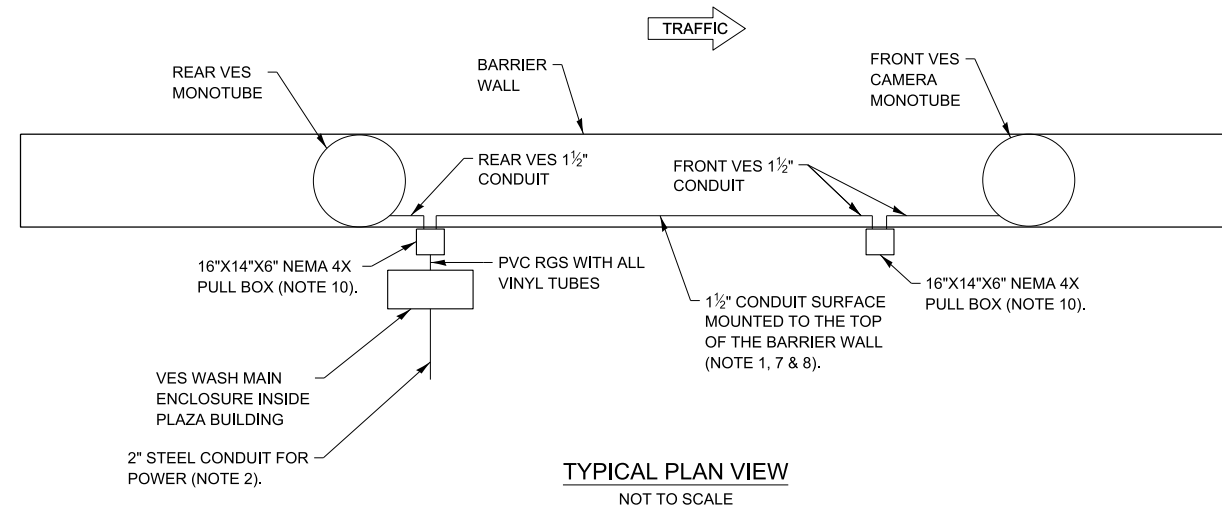

**TYPICAL PLAN VIEW**  
NOT TO SCALE

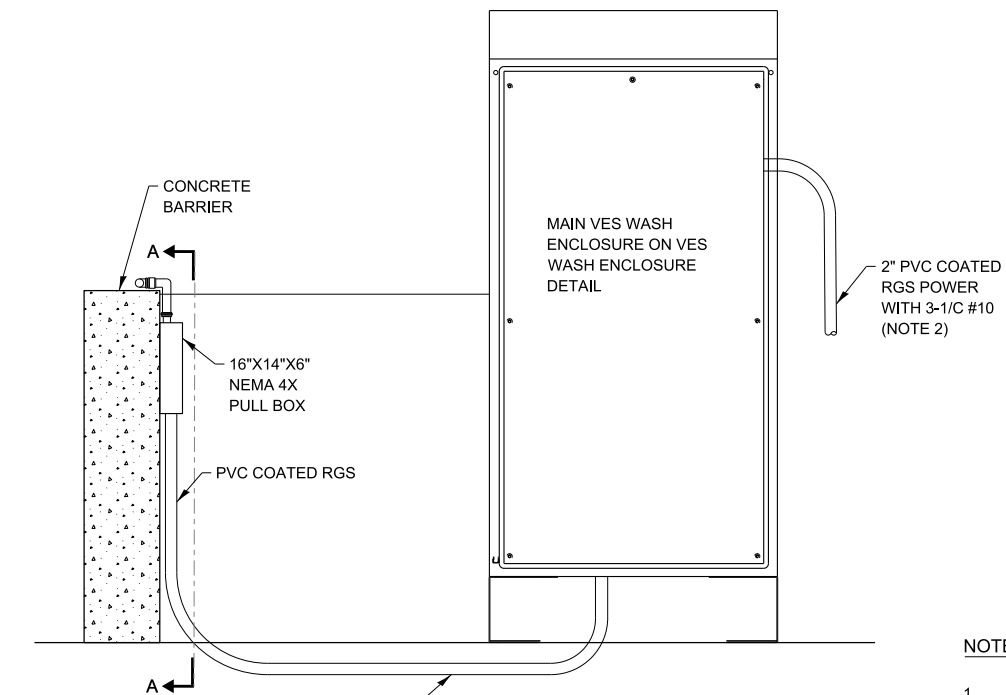

**MAIN ENCLOSURE MOUNTING DETAIL  
(OUTDOOR INSTALLATION ONLY)**  
NOT TO SCALE

2.5" DIA. PVC COATED RGS UNDERGROUND CONDUIT EXTEND (IF INSTALLED INSIDE) FROM BUILDING UP TO JUNCTION BOX OUTSIDE FOR VES WASH TUBING TO VES CAMERAS; (IF INSTALLED OUTSIDE) FROM CABINET TO JUNCTION BOX.

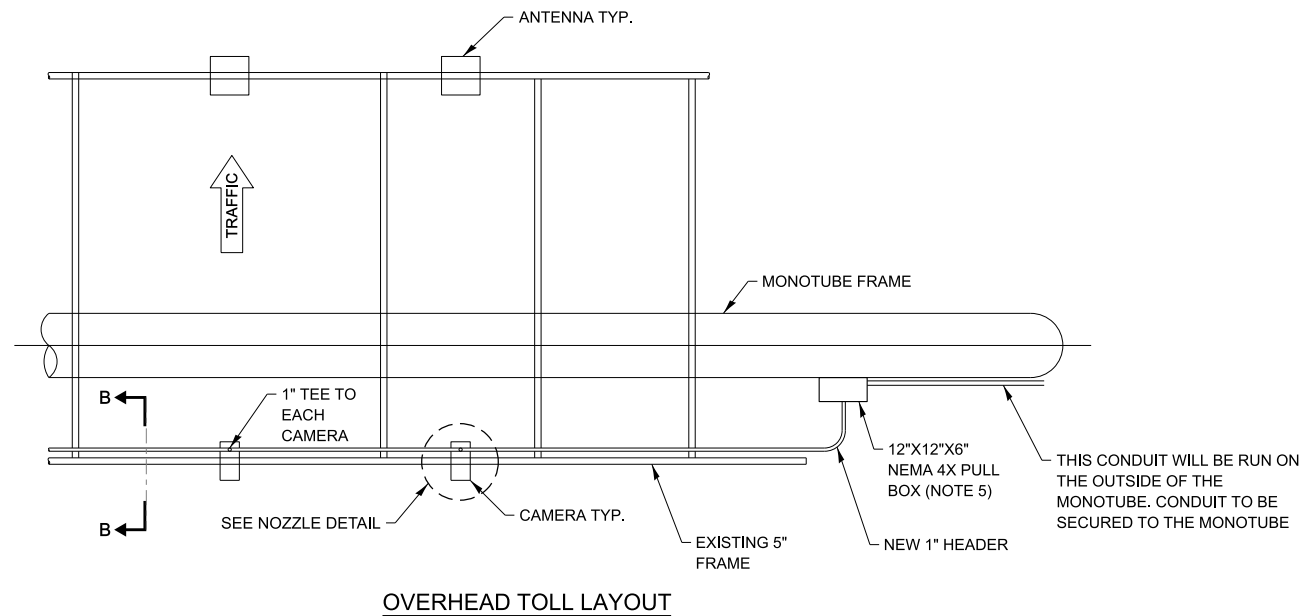

**OVERHEAD TOLL LAYOUT**

**NOTES:**

- ALL CONDUIT ROUTING AND EQUIPMENT PLACEMENT IS THE RESPONSIBILITY OF THE CONTRACTOR. THE ROUTING AND PLACEMENT DEPICTED IS SUGGESTED ONLY. ACTUAL ENCLOSURE LOCATION WILL VARY BASED ON SITE CONDITIONS. THE CONTRACTOR SHALL COORDINATE EQUIPMENT LOCATION AND CONDUIT ROUTING WITH CONSTRUCTION ENGINEER AND ILLINOIS TOLLWAY ENGINEER.
- THE POWER CONDUIT WILL RUN TO THE POWER PANEL INSIDE THE PLAZA BUILDING. THE NORMAL BREAKER PANEL WILL BE UTILIZED FOR THE VES WASH POWER SOURCE.
- UNLESS OTHERWISE NOTED ALL CONDUIT IS PVC COATED RGS.
- ONE (1) NEMA 4X 12"x12"x6" ENCLOSURE WILL BE PLACED ON THE REAR AND FRONT VES CAMERA MONOTUBE AND ONE (1) NEMA 4X 16"x14"x8" WILL BE PLACED ON THE BARRIER WALL AT EACH AET ZONE.
- MONOTUBE MOUNTED NEMA 4X PULL BOXES LOCATION TO BE DETERMINED IN FIELD. PULL BOX TO BE SECURELY FASTENED TO THE CONCRETE BARRIER. AT LEAST 1' OF SPOOLED UP VINYL TUBING FOR EACH CAMERA WILL BE PLACED IN THE MONOTUBE PULL BOXES.
- NOT USED.
- CONDUITS FOR SPRAY TUBING SHALL BE SEALED ON BOTH ENDS TO PREVENT WATER FROM PENETRATING.
- CONTRACTOR SHALL PROVIDE STRAIN RELIEF FOR WASHER TUBING IN POLES/MONOTUBES.
- FINAL POSITION AND NUMBER OF VES CAMERAS INSTALLED TO BE DETERMINED IN THE FIELD. NUMBER OF REAR VES CAMERAS SHOWN IS FOR ILLUSTRATION PURPOSES ONLY.
- 16"x14"x6" NEMA 4X PULL BOXES FOR THE REAR AND FRONT VES CAMERA MONOTUBE SHALL BE SURFACE MOUNTED ON THE RIGHT SHOULDER BARRIER WALL, AWAY FROM TRAFFIC.
- ALL CONDUITS, FITTINGS AND PENETRATIONS INTO EACH OF THE ENCLOSURES IN THE SYSTEM SHALL BE PROPERLY SEALED WITH ELECTRICAL PUTTY OR OTHER APPROVED SEALING METHODS TO PREVENT MOISTURE AND RODENT ENTRY.
- CONTRACTOR MUST VERIFY THAT THERE SHALL BE SUFFICIENT ROOM FOR CABINET DOOR TO OPEN.

**NOTE TO DESIGNER**

THIS BASE SHEET SHOWS TYPICAL CONSTRUCTION BUT IT IS NOT A STANDARD DRAWING. IT REQUIRES COMPLETION BY THE DESIGNER PRIOR TO INSERTION INTO A CONTRACT. MICROSTATION FILES AND THE "CADD STANDARDS MANUAL" ARE AVAILABLE ON THE ILLINOIS TOLLWAY WEBSITE. THE DESIGNER SHALL ACCEPT THE RESPONSIBILITY OF THE DESIGN OF THIS SHEET UPON ITS COMPLETION AND INSERTION INTO A CONTRACT. ALL "NOTE TO DESIGNER" BOXES SHALL BE REMOVED BY THE DESIGNER PRIOR TO INSERTION OF THE SHEET INTO THE PLAN SET.



**VES WASH SYSTEM  
SUGGESTED CONDUIT  
ROUTING**

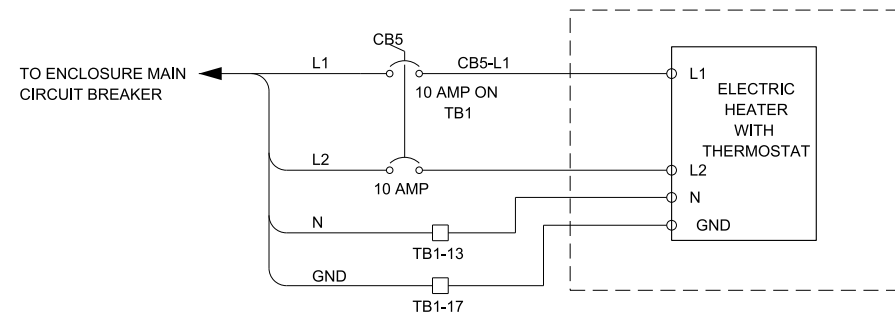

**ELECTRIC HEATER WITH THERMOSTAT  
(OUTDOOR INSTALLATION ONLY)**  
NOTE 4

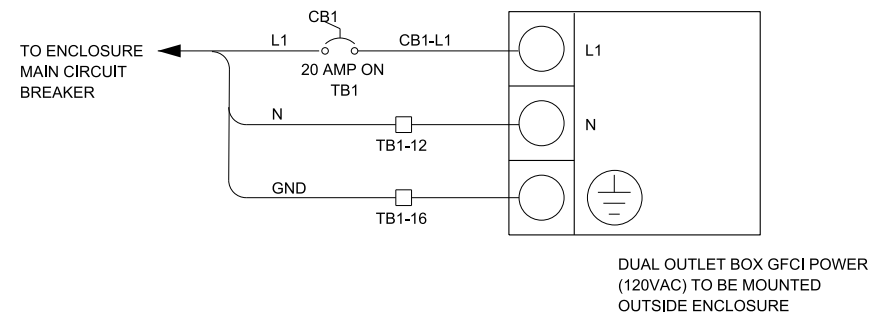

**ELECTRICAL DUAL OUTLET GFCI 20A**

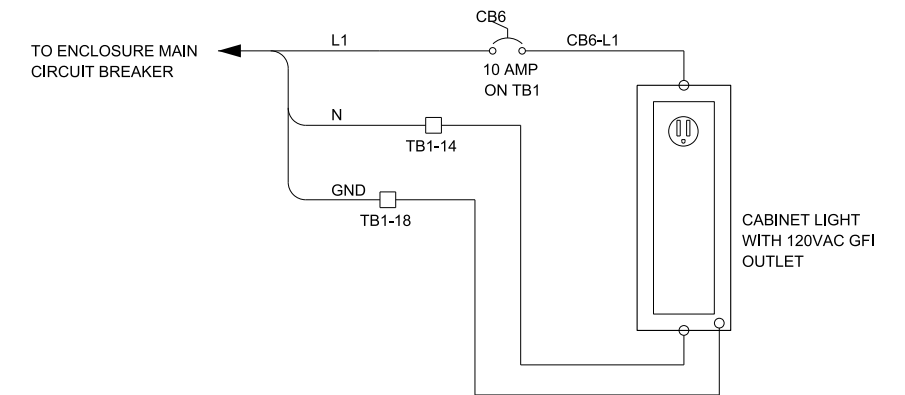

**CABINET LIGHTING AND GFI OUTLET**

**NOTES:**

1. ALL CABLING ON THIS DRAWING IS #12 AWG
2. MAIN BREAKER IS 25A. ILLUSTRATED ON VES WASH PANEL DETAIL ITEM U . LOCATED ON TOP DIN RAIL.
3. THREE 1-C #10 CABLES WILL BE ROUTED FROM THE MDP TO THE VES POWER WASH ENCLOSURE. THE POWER FEED WILL BE INITIATED FROM THE NORMAL BREAKER PANEL. THE CONTRACTOR TO SUPPLY AND INSTALL A 30A BREAKER IN THE MDP PANEL. POWER IS 120VAC WITH A HOT, NEUTRAL AND GROUND. THIS POWER FEED WILL THEN TERMINATE ON THE MAIN 25A BREAKER IN THE VES POWER WASH ENCLOSURE.
4. TO BE USED FOR OUTDOOR INSTALLATION ONLY

**NOTE TO DESIGNER**

THIS BASE SHEET SHOWS TYPICAL CONSTRUCTION BUT IT IS NOT A STANDARD DRAWING. IT REQUIRES COMPLETION BY THE DESIGNER PRIOR TO INSERTION INTO A CONTRACT. MICROSTATION FILES AND THE "CADD STANDARDS MANUAL" ARE AVAILABLE ON THE ILLINOIS TOLLWAY WEBSITE. THE DESIGNER SHALL ACCEPT THE RESPONSIBILITY OF THE DESIGN OF THIS SHEET UPON ITS COMPLETION AND INSERTION INTO A CONTRACT. ALL "NOTE TO DESIGNER" BOXES SHALL BE REMOVED BY THE DESIGNER PRIOR TO INSERTION OF THE SHEET INTO THE PLAN SET.



**GENERAL NOTES:**

1. ALL EXPOSED CONCRETE EDGES SHALL HAVE A 3/4" x 45° CHAMFER, EXCEPT WHERE SHOWN OTHERWISE. CHAMFER ON VERTICAL EDGES SHALL BE CONTINUED A MINIMUM OF ONE FOOT BELOW FINISHED GROUND LEVEL.

**REINFORCEMENT BARS:**

1. REINFORCEMENT BARS, INCLUDING REINFORCEMENT BARS, EPOXY-COATED SHALL CONFORM TO THE REQUIREMENTS OF IDOT STANDARD SPECIFICATIONS SECTION 508 AND ARTICLE 1006.10.
2. REINFORCEMENT BARS DESIGNATED "(E)" SHALL BE EPOXY-COATED.
3. REINFORCEMENT BENDING DETAILS SHALL BE IN ACCORDANCE WITH THE LATEST EDITION OF ACI 315, "MANUAL OF STANDARD PRACTICE FOR DETAILING REINFORCED CONCRETE STRUCTURES".
4. REINFORCEMENT BAR BENDING DIMENSIONS ARE OUT-TO-OUT.
5. COVER FROM THE FACE OF CONCRETE TO FACE OF REINFORCEMENT BARS SHALL BE 3" FOR SURFACES FORMED AGAINST EARTH AND 2" FOR ALL OTHER SURFACES UNLESS OTHERWISE SHOWN.

**CONSTRUCTION SPECIFICATIONS:**

1. ILLINOIS TOLLWAY SUPPLEMENTAL SPECIFICATIONS ISSUED MARCH, 2023 TO THE ILLINOIS DEPARTMENT OF TRANSPORTATION STANDARD SPECIFICATIONS FOR ROAD AND BRIDGE CONSTRUCTION.
2. ILLINOIS DEPARTMENT OF TRANSPORTATION SUPPLEMENTAL SPECIFICATIONS AND RECURRING SPECIAL PROVISIONS ADOPTED JANUARY 1, 2023.
3. ILLINOIS DEPARTMENT OF TRANSPORTATION STANDARD SPECIFICATIONS FOR ROAD AND BRIDGE CONSTRUCTION ADOPTED JANUARY 1, 2022.

**DESIGN LOADING:**

LIVE LOAD, CONTROLLING CASE OF THE FOLLOWING:

- 100 P.S.F.
- 2,000 LB. CONCENTRATED FORCE OR KNOWN LOADING PROVIDED BY ITS

SNOW LOAD: 50 P.S.F.

WIND SPEED: 120 M.P.H. APPLIED TO BUILDING WALLS, PER ASCE 7-16

DEAD LOAD: 30,000 POUNDS (12'x30' BUILDING) OR 20,000 POUNDS (12'x20' BUILDING) SELF WEIGHT OF SLAB

**DESIGN STRESSES FOR REINFORCED CONCRETE:**

$f_c$  = COMPRESSIVE STRENGTH OF CONCRETE (CLASS SI) = 3,500 P.S.I.

$f_y$  = YIELD STRENGTH OF REINFORCEMENT BARS (GRADE 60) = 60,000 P.S.I.

**DESIGN SPECIFICATIONS:**

1. ILLINOIS TOLLWAY STRUCTURE DESIGN MANUAL ISSUED MARCH, 2023.
2. INTERNATIONAL BUILDING CODE, 2021.
3. ASCE 7-16 MINIMUM DESIGN LOADS AND ASSOCIATED CRITERIA FOR BUILDINGS AND OTHER STRUCTURES, 2017.
4. ACI 318-19 BUILDING CODE REQUIREMENTS FOR STRUCTURAL CONCRETE, 2022.
5. ILLINOIS DEPARTMENT OF TRANSPORTATION BRIDGE MANUAL, JANUARY 2023.
6. ILLINOIS TOLLWAY GEOTECHNICAL ENGINEER MANUAL DATED MARCH 2022.

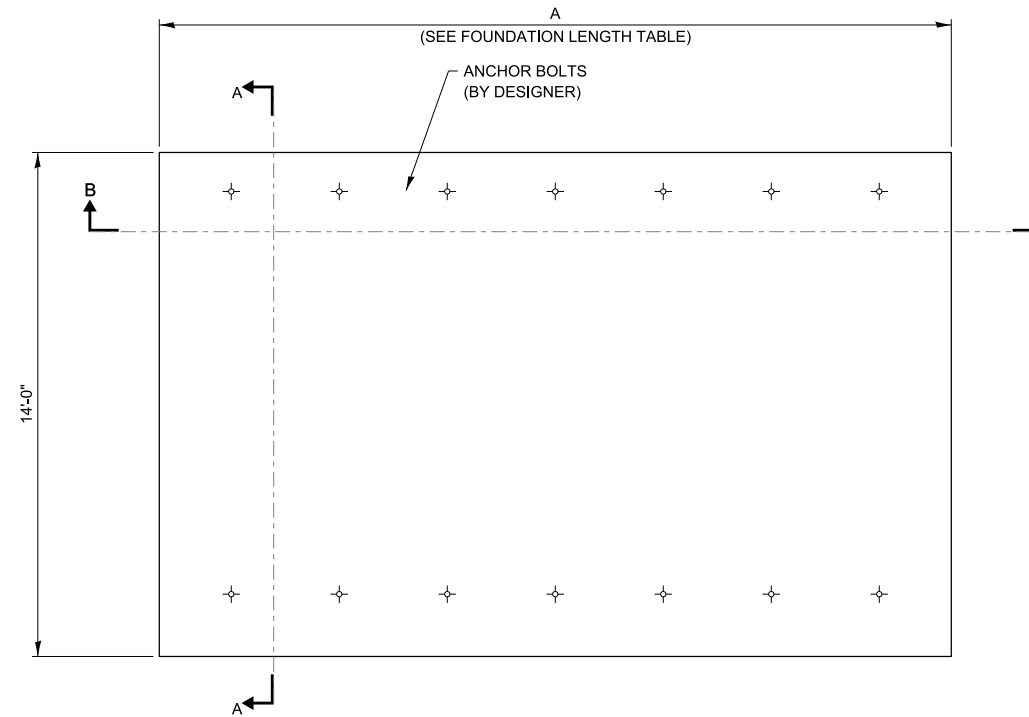

FOUNDATION LENGTH TABLE	
TOLL PLAZA BUILDING TYPE	DIMENSION
MAIN TOLL PLAZA BUILDING WITH GENERATOR	A = 32'
REMOTE TOLL PLAZA BUILDING WITHOUT GENERATOR	A = 22'

**PLAN VIEW**

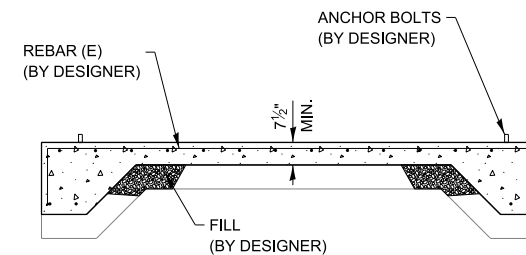

**SECTION A-A**

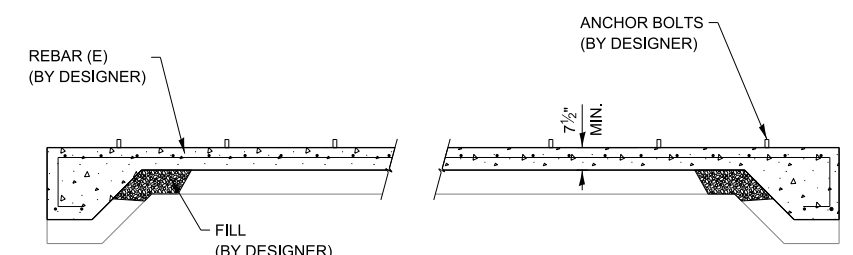

**SECTION B-B**

**NOTE TO DESIGNER**

ALL "NOTE TO DESIGNER" BOXES SHALL BE REMOVED BY THE DESIGNER PRIOR TO INSERTION OF THE SHEET INTO THE PLAN SET.

THIS DRAWING IS A CONCEPT FOUNDATION FROM A BUILDING MANUFACTURER. THE FOUNDATION MUST HAVE A FLAT TOP SLAB AS SHOWN IN THE DRAWING TO SUPPORT THE BUILDING FRAME.

THE DESIGNER SHALL DESIGN THE TOP SLAB, FOOTERS, WALLS AND REINFORCING DETAILS AS NECESSARY TO SUPPORT THE BUILDING AND MEET LOCAL CODES.

LOADS SHOWN ARE MINIMUM. IF ACTUAL LOADS ARE LARGER, REPLACEMENT MINIMUM LOADS SHOWN.

THE DESIGN IS BASED ON AN ALLOWABLE SOIL BEARING PRESSURE OF 2,000 P.S.F.



**PLAZA CONTROL BUILDING  
CONCRETE FOUNDATION**

VERSION: 2021-03	BASE SHEET: M-BUS-2544	SHEET: 1 OF 1
---------------------	---------------------------	------------------