

Illinois Tollway Base Sheet Revisions
--

Section M Base Sheet Drawings	
Drawing	Modification Summary Effective: 03-01-2026
Flashing Sign Beacon (ITS)-Series 1700	
M-ITS-1701	Cabinet Layout and Wiring ITS Pole Mounted Enclosure (1-CCTV and Flashing Sign Beacon)
Sheet 1	Replace GFI plugs by Non GFI plugs and identify top power outlet as DIN 1 and bottom power outlet as DIN 2
	Remove one spare AC/DC power supply CLICK-204
	Removed space reserved for surge suppressor for MVDS-1, MVDS-2 and MVDS-3 on DIN rail
	Installed one spare 5A breaker as part of breaker terminal
	Changed designation of HOT 3 terminal block to CB10A
	Item AQ PoE power injector changed to Axis TU8003 90W Midspan 120VAC
	Added Item AV as Axis T91A03 DIN Rail Clip B
	Added Note 31: PoE power cable shall be free standing from PoE to power outlet

 **New Sheet**

 **Retired Standard**

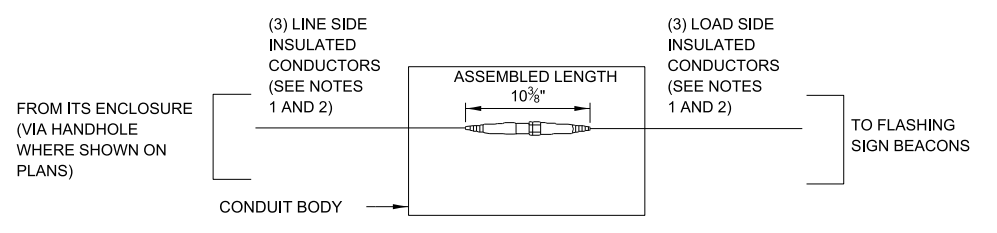
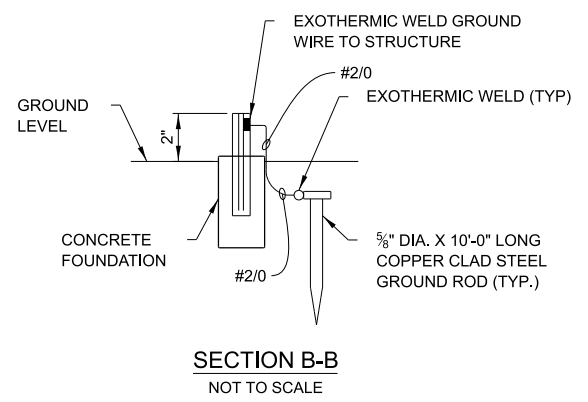
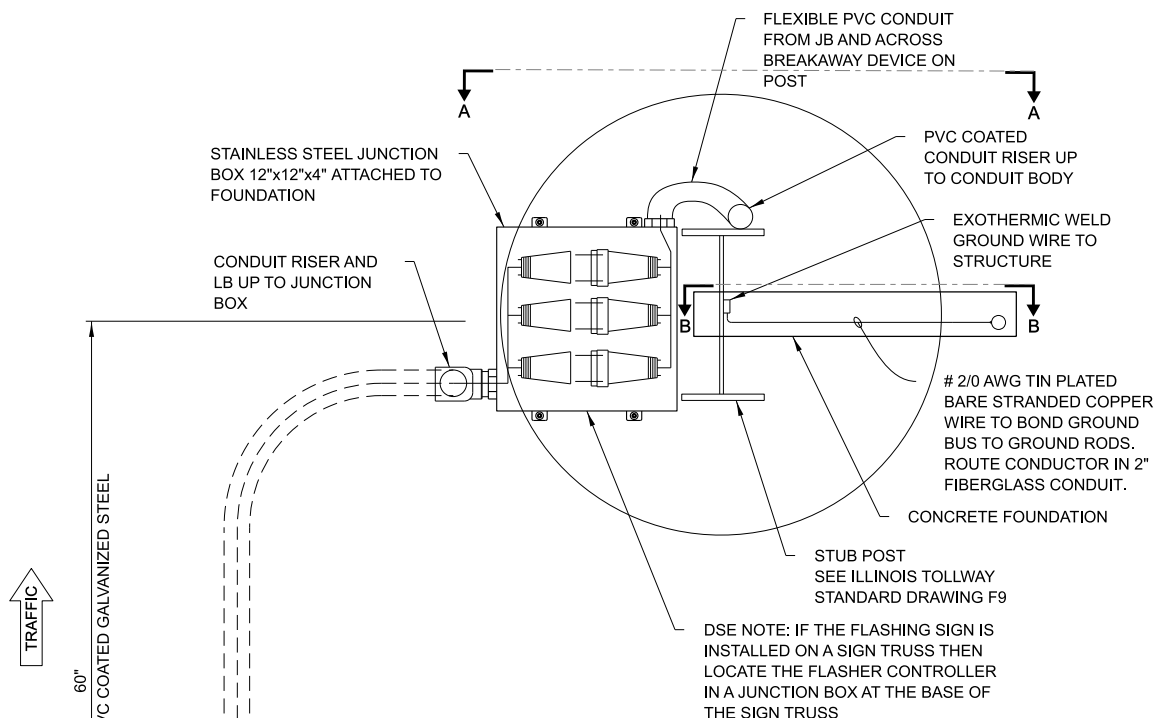

NON-FUSED BREAKAWAY ELECTRICAL CONNECTORS

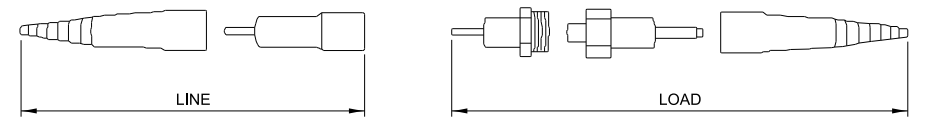

NON-FUSED BREAKAWAY ELECTRICAL CONNECTORS
EXPLODED VIEW

NOTE TO DESIGNER
 IF AN EXISTING ITS CABINET LIES WITHIN 500 FEET OF THE IMMEDIATE PROXIMITY OF THE FLASHING BEACON EQUIPMENT, POWER CAN BE CONNECTED THROUGH THAT CABINET. OTHERWISE, A SEPARATE ITS CABINET IS REQUIRED.

NOTE TO DESIGNER
 INSTALL A NEW CCTV WITHIN 500 FEET UPSTREAM OF THE FLASHING BEACON CABINET IF THERE IS NO EXISTING CCTV WITHIN 500 FEET OF THE NEW SITE.

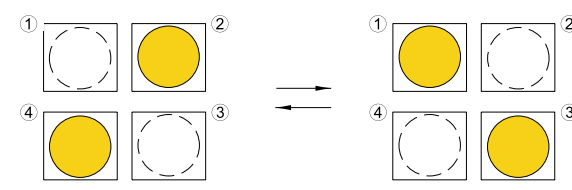

FLASHING SEQUENCE
NOT TO SCALE

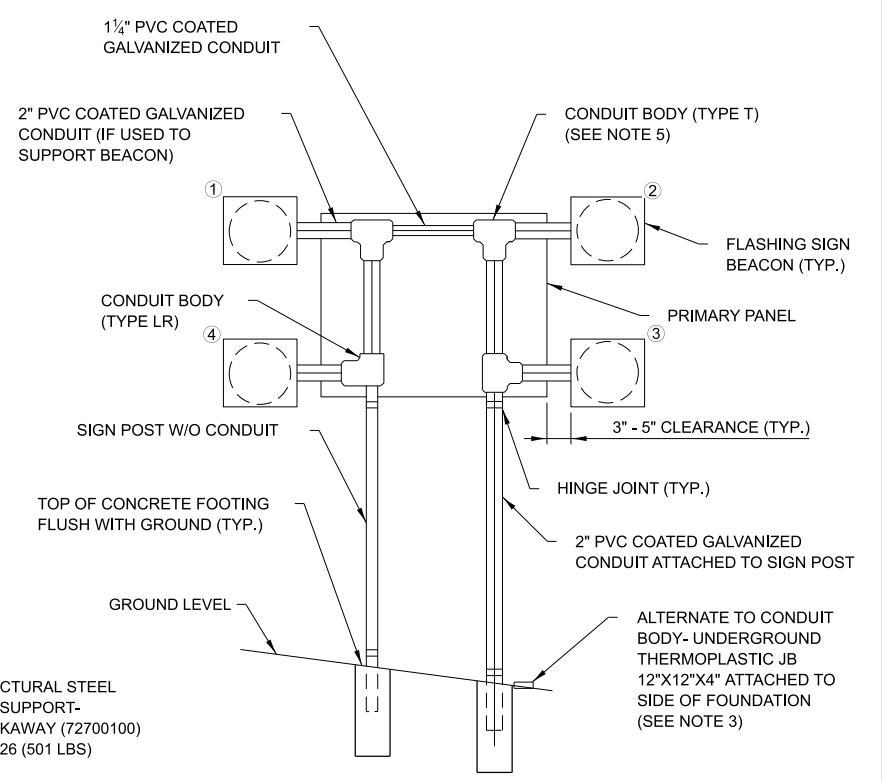

ELEVATION A-A
NOT TO SCALE

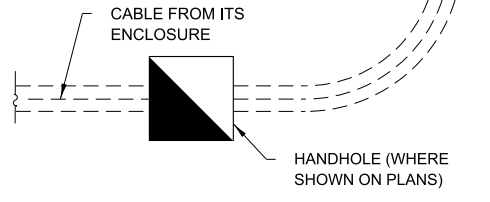

TYPICAL PLAN AT FLASHING BEACON
NOT TO SCALE

RAMP QUEUE WARNING SIGN (I)
SIGN INSTALLATION, TYPE 3
(J5720120) (84 SQ. FT.)
 STATIC SIGN FLASHING BEACON
ASSEMBLY INSTALLATION (JT
1322850) (1 EACH)

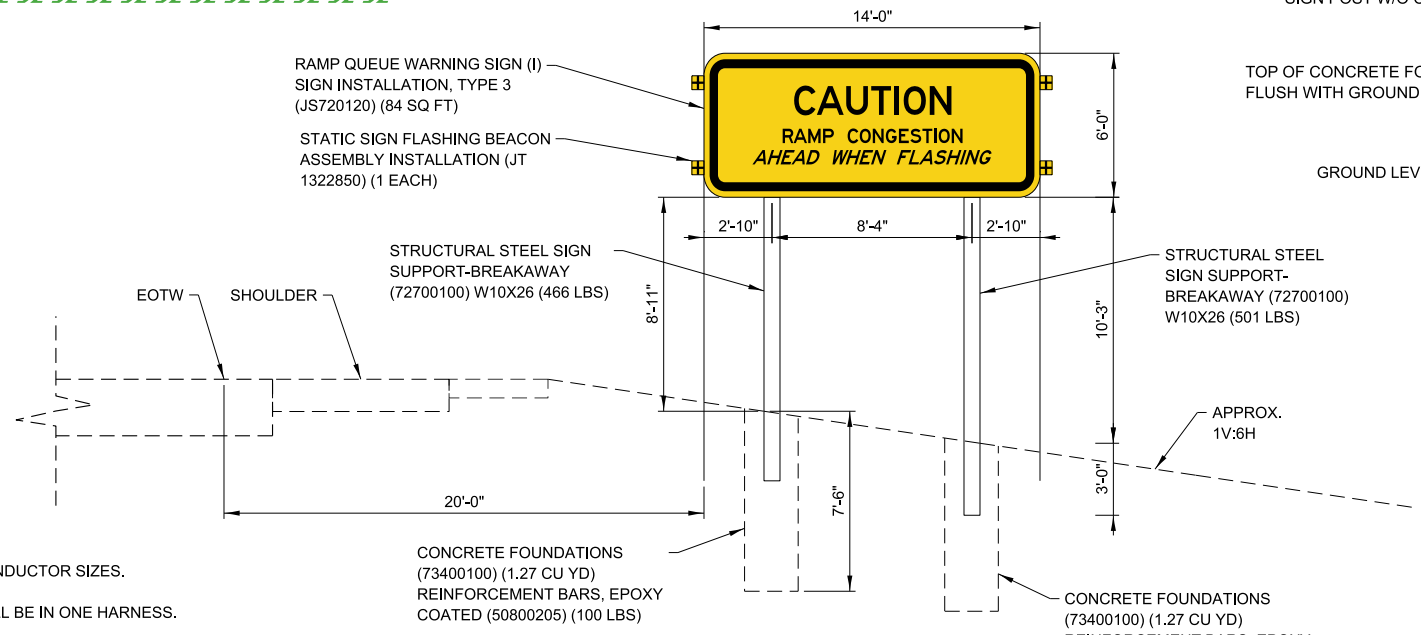

RAMP QUEUE WARNING SIGN

NOTE TO DESIGNER
 THIS BASE SHEET SHOWS TYPICAL CONSTRUCTION BUT IT IS NOT A STANDARD DRAWING. IT REQUIRES COMPLETION BY THE DESIGNER PRIOR TO INSERTION INTO A CONTRACT. MICROSTATION FILES AND THE "CADD STANDARDS MANUAL" ARE AVAILABLE ON THE ILLINOIS TOLLWAY WEBSITE. THE DESIGNER SHALL ACCEPT THE RESPONSIBILITY OF THE DESIGN OF THIS SHEET UPON ITS COMPLETION AND INSERTION INTO A CONTRACT. ALL "NOTE TO DESIGNER" BOXES SHALL BE REMOVED BY THE DESIGNER PRIOR TO INSERTION OF THE SHEET INTO THE PLAN SET.

- NOTES:**
- SEE PLANS FOR REQUIRED CONDUCTOR SIZES.
 - ALL THREE CONDUCTORS SHALL BE IN ONE HARNESS.
 - AS AN ALTERNATE TO THE CONDUIT BODY ON FOUNDATION, USE THERMOPLASTIC JUNCTION BOXES (CARLON PART NO. E989UUN OR APPROVED EQUAL)
 - PROVIDE 50' OF SLACK IN LINE SIDE CABLE IN HANDHOLE.



**FLASHING SIGN BEACON
INSTALLATION BREAKAWAY
ELECTRICAL DETAIL**

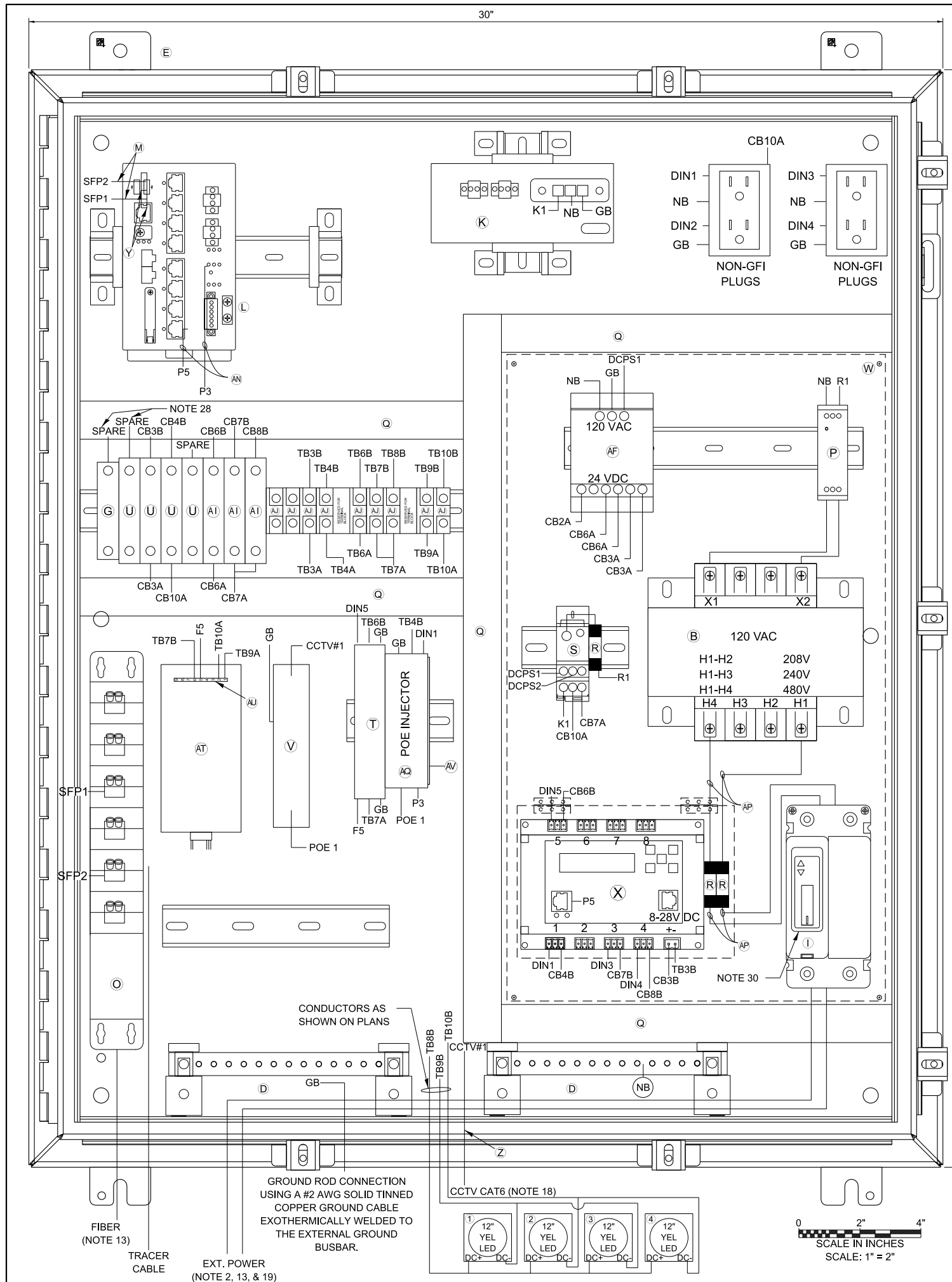

ITEM	DESCRIPTION
A	NOT USED FOR THIS SHEET APPLICATION
B	CONTROL POWER TRANSFORMER, 1000VA, 208/240/480-120VAC, 1PH SQUARE D/CLASS 9070 - T1000 D95
C	NOT USED FOR THIS SHEET APPLICATION
D	TWO (2) GROUNDING BAR SYSTEM HOFFMAN/PGS2K. BONDED OR SEPARATED AS REQUIRED.
E	NEMA 4X STAINLESS STEEL, 36"H X 30"W X 12"D ENCLOSURE WITH 33"x27" PANEL, HOFFMAN/A36H3012SS6LP & A36P30
F	TWO DUPLEX 120V RECEPTACLES, ONE GFCI AND NON-GFI (SEE NOTE 9) HUBBELL/GFR5362 & BR20WR
G	24VDC, 1P, 15A CIRCUIT BREAKER SCHNEIDER ELECTRIC/MGN61510 NOT USED FOR THIS SHEET APPLICATION
H	NOT USED FOR THIS SHEET APPLICATION
I	480V, 2P, 30A CIRCUIT BREAKER WITH TERMINAL SHIELD EATON/HFD2030L & 625B229G07
J	NETWORK SWITCH CISCO IE-3300-8T2S-E
K	CISCO POWER SUPPLY, PWR-JE170W-PC-AC=
L	IP SERVICES LICENSE: IE3300-DNS-A-3Y
M	2 METER - SMFO LC-LC DUPLEX JUMPERS, CORNING/040402R5Z20002M
N	NOT USED FOR THIS SHEET APPLICATION
O	SMF PATCH PANEL WITH LC CONNECTORS
P	120VAC SURGE SUPPRESSOR, MOUNTED ON DIN RAIL COOPER CROUSE HINDS/MA15/D/1/SI OR APPROVED EQUAL
Q	PANDUIT WIRING DUCT (OR EQUIVALENT) PANDUIT/F1X2LG6 WITH COVER-C1LG6 10 AMP FUSE, GOULD (MERSEN)/ATM-10
R	10 AMP FUSE, GOULD (MERSEN)/ATM-10
S	SPLICE BLOCK, ALTECH/38041
T	24VAC/VDC SURGE SUPPRESSOR, MOUNTED ON DIN RAIL MTL INSTRUMENTS/ZB24580
U	5A CIRCUIT BREAKER, ALLEN BRADLEY/1492-SPM1B050
V	CAT6 PoE+ SURGE SUPPRESSOR: USE AXIS T8061 FOR AXIS PoE CAMERA.
W	CLEAR POLY METHYL METHACRYLATE (PMMA, PLEXIGLAS) SAFETY COVER ENCOMPASSING ITEMS AF, P, S, R, B, X, & I. (THE INSTALLER SHALL PERMANENTLY AFFIX A LABEL STATING "DANGER 480 VAC" OR "DANGER 240 VAC" OR "DANGER 120 VAC" FOR 120 VAC AS FIELD CONDITIONS WARRANT.) COMES WITH ACCESS DOOR FOR IP RELAY. REFER TO ITEM X.
X	POWER CONTROLLER, 8-CHANNEL DIN ETHERNET RELAY DIGITAL LOGGERS/DIN 4
Y	(2) CISCO GLC-LX-SM-RGD = 1 GBPS SM SFP MODULES
Z	CATEGORY 6 CABLE, 23 AWG, OUTDOOR RATED CABLE BELDEN/7953A
AA	SENSOR SURGE SUPPRESSION, WAVETRONIX - CLICK-200 OR ISS ZONE BARRIER ZB24510
AB	NOT USED FOR THIS SHEET APPLICATION
AC	NOT USED FOR THIS SHEET APPLICATION
AD	NOT USED FOR THIS SHEET APPLICATION
AE	RS-232 / RS-485 TO ETHERNET CONVERTOR WAVETRONIX - CLICK-301 OR ISS-MOXA P5150T, DK-35T
AF	AC/DC POWER SUPPLY, 24VDC WAVETRONIX - CLICK-204 OR ISS LAMBDA DSP100-24
AG	NOT USED FOR THIS SHEET APPLICATION
AH	NOT USED FOR THIS SHEET APPLICATION
AI	2A CIRCUIT BREAKER, ALLEN BRADLEY/1492-SPM1B020
AJ	TERMINAL BLOCK, ALLEN BRADLEY/1492-CD8
AK	MVDS ASSEMBLY (NOT SHOWN), SEE SPECIAL PROVISIONS
AL	TRANSFORMER COVERS, SQUARE D/9070FSC2
AM	5-CONDUCTOR JUMPER (Tx, Rx, GND, RTS, CTS), RS-232 SERIAL COMMUNICATIONS (APPLICABLE TO ISS/MOXA)
AN	INDOOR/OUTDOOR RATED CAT6 (1000MBS, TEMPERATURE HARDENED) THESE ARE THE CAT6 CABLES ROUTED INSIDE CABINET
AO	MVDS CABLE
AP	#10 AWG
AQ	PoE INJECTOR AXIS TU8003 90W MIDSPAN 120VAC
AR	T-BUS CONNECTOR (WAVETRONIX)
AS	NOT USED FOR THIS SHEET APPLICATION
AT	ELTEC FS-4 DC FLASHER
AU	9 PIN HARNESS FOR FS-4
AV	AXIS T91A03 DIN RAIL CLIP B

- NOTES:**
- ALL POWER WIRING SHALL BE RHH/RHW WITH WIRE TERMINALS OR TINNED.
 - CONTRACTOR TO VERIFY CORRECT TRANSFORMER TAPS ARE USED BASED ON INCOMING POWER SOURCE.
 - ALL CABLES AND EQUIPMENT SHALL BE PROPERLY DRESSED AND LABELED. ALL CONDUITS SHALL BE PROPERLY PLUGGED WITH DUCT SEAL PUTTY (RAINBOW TECHNOLOGIES OR EQUIVALENT).
 - NOT USED FOR THIS SHEET APPLICATION.
 - EACH 120VAC OUTLET, PS OR TRANSFORMER (ITEM F, K, L, & AF) SHALL BE FED FROM A SEPARATE INPUT LINE.
 - THE DIN RAIL(S) FOR ITEMS J & K SHALL BE INSTALLED WITH THE CENTER LINE NO LESS THAN 5 INCHES FROM ANY OBSTACLE ABOVE AND NO LESS THAN 4 INCHES FROM ANY OBSTACLE BELOW. ALL DIN RAIL SHALL BE GROUNDED.
 - ALL CABLES INSTALLED WITHIN THE CABINET AND POLE SHALL BE OUTDOOR RATED.
 - WIFI COMMUNICATION SHALL BE DISABLED ON DIN ETHERNET RELAY.
 - THE GFI OUTLETS LOAD SHALL NOT BE CONNECTED TO ANY OTHER LOAD IN THE ENCLOSURE. THE 1900 QUAD BOX GFI'S ARE INTENDED TO BE UTILIZED FOR EXTERNAL EQUIPMENT ONLY. EACH OUTLETS TAB SHALL BE BROKEN SO THEY ARE INDEPENDENT.
 - ALL BREAKERS SHALL BE LABELED (E.G. CAMERA-AC, CAMERA-DC, DIN RELAY-AC, DIN RELAY-DC, CELL MODEM-AC ETC.).
 - NOT USED FOR THIS SHEET APPLICATION
 - USE THE MOUNTING TABS ON THE IP RELAY UNIT TO MOUNT THE UNIT DIRECTLY TO THE BACK PLATE. REFER TO THE IP RELAY WIRING TABLE FOR WIRING DETAILS.
 - ALL CABLES SHALL ENTER THE ENCLOSURE FROM THE BOTTOM. ALL POWER AND COMMUNICATION CABLE SLACK SHALL BE PLACED IN THE HANDHOLE.
 - POWER FEED TO THE CISCO IE4000 SWITCH SHALL BE FROM THE 120VAC INPUT WHEN THE ENCLOSURE IS AC POWERED.
 - NOT USED FOR THIS SHEET APPLICATION
 - IF A SOLAR GENERATOR IS CONNECTED, THEN ITEM P AND THE SECONDARY SIDE OF ITEM B SHALL BE CONNECTED UNTIL A FINAL AC CONNECTION IS MADE.
 - ITEM X IS USED TO CONTROL POWER TO THE CAMERAS AND DETECTORS. ALL 120VAC CONNECTIONS ON ITEM X SHALL BE PROTECTED.
 - CABLES TO BE ROUTED THROUGH POLE.
 - WHEN A 24VDC TO 120VAC POWER GENERATOR IS CONNECTED, THEN THE 480VAC TO 120VAC STEP DOWN TRANSFORMER IS BYPASSED.
 - NOT USED FOR THIS SHEET APPLICATION
 - NOT USED FOR THIS SHEET APPLICATION
 - DIN RAIL SHALL BE INSTALLED AS ILLUSTRATED ON DRAWING. DIN RAIL SHALL BE GROUNDED TO THE GROUND BUS.
 - BOND NEUTRAL AND GROUND BUSES TOGETHER, WHEN REQUIRED. TIE THE ENCLOSURE INTO THE GROUND BUS.
 - ITEM W SHALL BE FORMED AND MOLDED TO FIT AROUND THE AREA DENOTED BY THE DASHED LINE. THE PLEXIGLASS SHALL BE MOUNTED TO THE BACKPLATE WITH SUFFICIENT AIR HOLES TO ALLOW HEAT TO ESCAPE THE AREA. THERE SHALL ALSO BE OPENINGS ON THE BOTTOM TO ALLOW CABLES TO BE PASSED FROM THE AC SECTION TO THE OTHER SECTIONS OF THE ENCLOSURE.
 - ITEM AL SHALL BE PLACED ON ITEM B.
 - ALL INTERNAL ENCLOSURE ROUTED AND TERMINATED CAT6 CABLE SHALL BE TEMPERATURE RATED.
 - ALL INTERNAL 24VAC, 120VAC (STARTING ON SECONDARY SIDE OF ITEM B) AND ANY DC VOLTAGE POWER FEEDS USE #16 AWG CABLE.
 - SPARE BREAKER RESERVED.
 - ALL CONDUIT EXITING THE BOTTOM OF THE CABINET SHALL BE INSTALL IN-LINE WITH THE EQUIPMENT IT IS CONNECTED TO. THE CABLES SHALL BE INSTALLED IN A NEAT AND PROFESSIONAL MANNER.
 - PROVIDE WINDOW IN PMMA SHIELD FOR ACCESS TO BREAKER. MOUNT BREAKER FLUSH WITH PMMA SHIELD USING MOUNTING BRACKET.
 - PoE POWER CABLE SHALL BE FREE STANDING FROM PoE TO POWER OUTLET.

NOTE TO DESIGNER

THIS BASE SHEET SHOWS TYPICAL CONSTRUCTION BUT IT IS NOT A STANDARD DRAWING. IT REQUIRES COMPLETION BY THE DESIGNER PRIOR TO INSERTION INTO A CONTRACT. MICROSTATION FILES AND THE "CADD STANDARDS MANUAL" ARE AVAILABLE ON THE ILLINOIS TOLLWAY WEBSITE. THE DESIGNER SHALL ACCEPT THE RESPONSIBILITY OF THE DESIGN OF THIS SHEET UPON ITS COMPLETION AND INSERTION INTO A CONTRACT. ALL "NOTE TO DESIGNER" BOXES SHALL BE REMOVED BY THE DESIGNER PRIOR TO INSERTION OF THE SHEET INTO THE PLAN SET.

NOTE TO DESIGNER

DSE SHALL SPECIFY THE GATOR PATCH CABLE LENGTH PER SITE AND UPDATE ITEM (O) TO INCLUDE THIS LENGTH.

CABINET LAYOUT AND WIRING ITS POLE MOUNTED ENCLOSURE (1-CCTV AND FLASHING SIGN BEACON)

VERSION: 2026-03 BASE SHEET: M-ITS-1701 SHEET: 1 OF 1

GROUND ROD CONNECTION USING A #2 AWG SOLID TINNED COPPER GROUND CABLE EXOTHERMICALLY WELDED TO THE EXTERNAL GROUND BUSBAR.

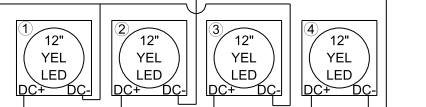
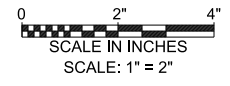

EXT. POWER (NOTE 2, 13, & 19)

FIBER (NOTE 13)
TRACER CABLE