

<b>Illinois Tollway Standard Drawing Revisions</b>
--

<b>Section B</b>	<b>Drainage Structures, Curbs &amp; Gutter</b>	
	<b>Drawing</b>	<b>Modification Summary</b> <span style="float: right;"><b>Effective: 03-01-2026</b></span>
	<b>B8-10</b>	<b>Catch Basins Type G and Type G-3 Modified, Frames and Grates</b>
	Sheet 1	Revised Note 5.

 **New Sheet**

 **Retired Standard**

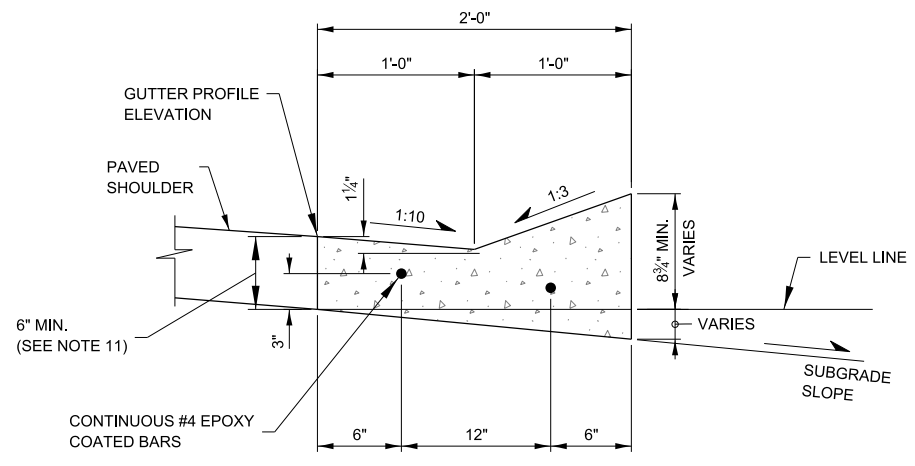

GUTTER, TYPE G-2

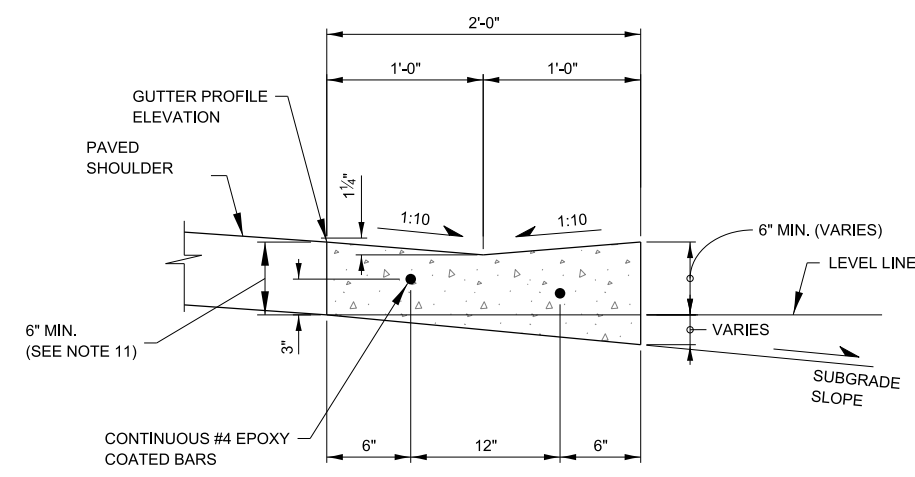

GUTTER, TYPE G-2, MODIFIED

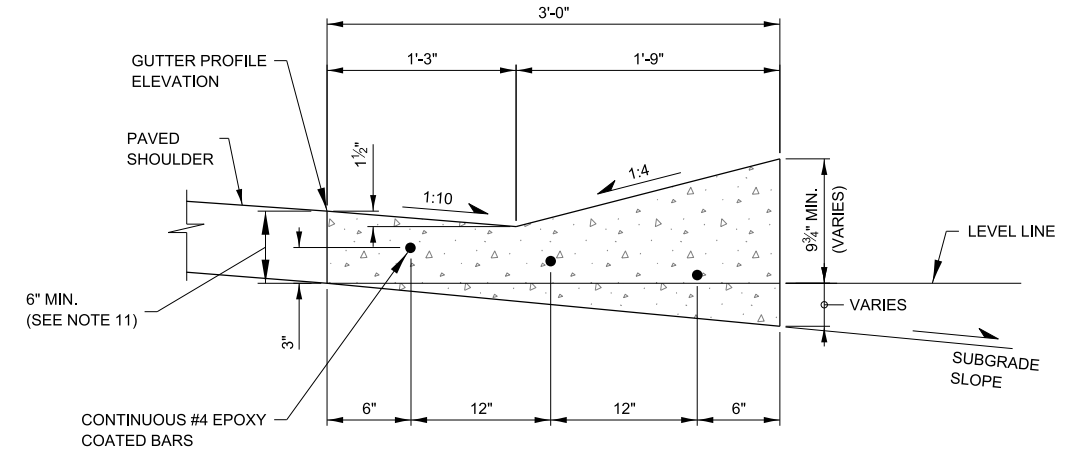

GUTTER, TYPE G-3

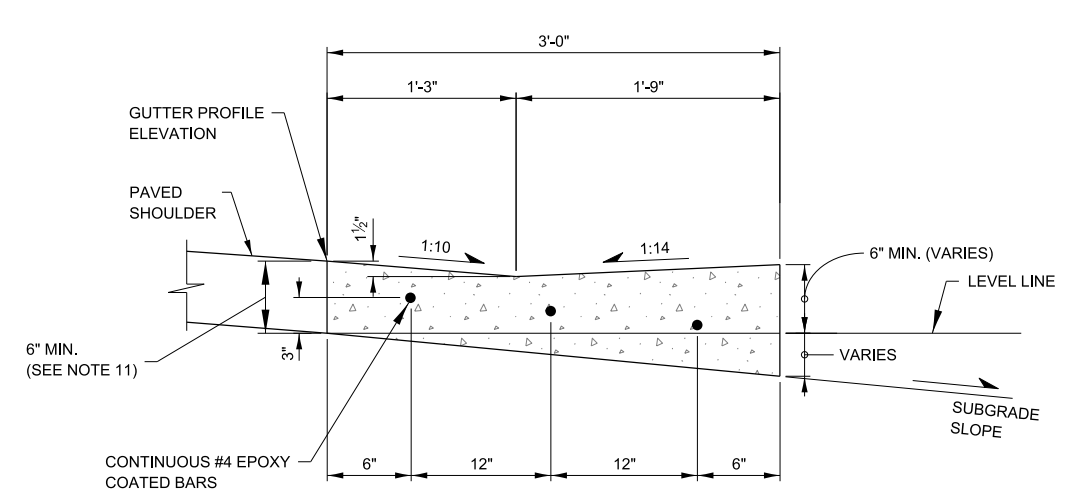

GUTTER, TYPE G-3, MODIFIED

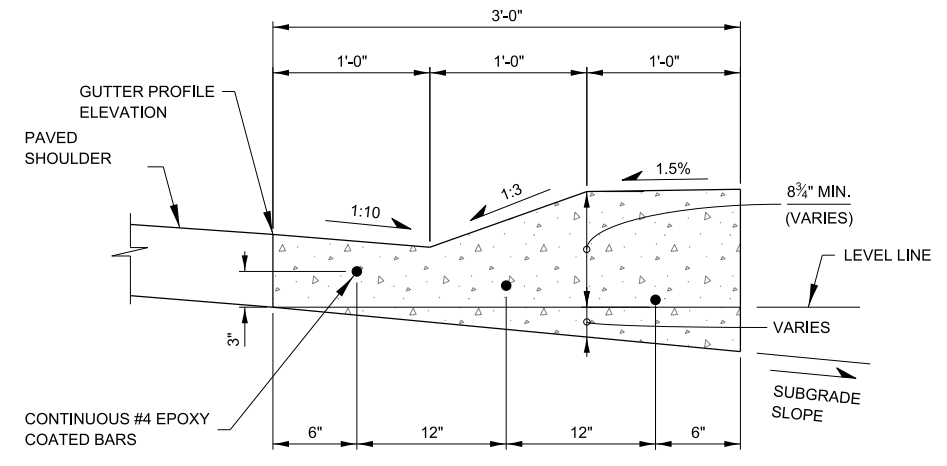

GUTTER, TYPE G-2N

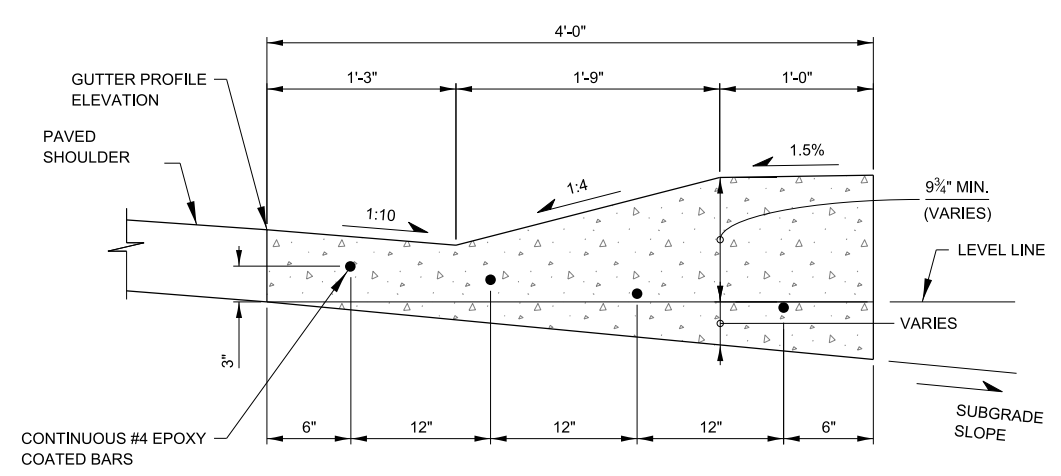

GUTTER, TYPE G-3N

NOTES:

- FOR CONCRETE CURB, TYPE C TRANSITIONS, THE LEADING ENDS OF CURB IN THE DIRECTION OF TRAFFIC SHALL BEGIN FLUSH WITH ADJACENT PAVEMENT OR SHOULDER SURFACE AND TRANSITION TO FULL HEIGHT AT THE RATE OF ONE INCH VERTICAL TO ONE FOOT HORIZONTAL.
- | GUTTER TRANSITION DETAILS                    | STANDARD DRAWING |
|--|------------------|
| TRAFFIC BARRIER TERMINAL TYPE T1 (SPECIAL)   | B-28             |
| TRAFFIC BARRIER TERMINAL TYPE T1-A (SPECIAL) | B-29             |
| TRAFFIC BARRIER TERMINAL TYPE T10            | B-2              |
| TRAFFIC BARRIER TERMINAL TYPE T6             | B-3              |
- ALL SLOPES ARE EXPRESSED AS UNITS OF VERTICAL DISPLACEMENT TO UNITS OF HORIZONTAL DISPLACEMENT (V:H).
- REINFORCEMENT STEEL SHALL BE ACCURATELY PLACED AND FIRMLY HELD IN THE POSITION SPECIFIED USING EPOXY COATED STEEL CHAIRS. CHAIR SPACING SHALL NOT EXCEED 4'-0".
- GUTTER REINFORCEMENT SHALL BE PLACED 3" ABOVE BOTTOM OF GUTTER FOLLOWING THE SUBGRADE SLOPE.
- OTHER GUTTER AND CURB TRANSITION DETAILS WILL BE SHOWN ON THE PLANS.
- CONTINUOUS #4 BARS SHALL BE LAPPED A MINIMUM OF 1'-1".
- FOR CONCRETE GUTTER OVERLAYS, CRACK CONTROL JOINTS SHALL BE PLACED AT LOCATIONS OF UNDERLYING JOINTS AND WORKING CRACKS.
- GUTTER CRACK CONTROL JOINTS TO ALIGN IN PROLONGATION WITH PCC SHOULDER JOINTS WHERE EXISTING. CRACK CONTROL JOINTS SHALL BE SEALED FULL DEPTH AND WIDTH IN ACCORDANCE WITH THE STANDARD SPECIFICATIONS.
- EXPANSION JOINTS SHALL BE CONSTRUCTED IN GUTTER AT MAXIMUM JOINT SPACING OF 60'-0". SEE EXPANSION JOINT DETAIL ON SHEET 3 OF THIS STANDARD.
- GUTTER DEPTH SHALL MATCH PAVED SHOULDER DEPTH.
- THIS WORK WILL BE MEASURED FOR PAYMENT IN FEET ALONG THE FLOW LINE OF THE GUTTER, WHICH MEASUREMENT WILL INCLUDE DRAINAGE CASTINGS INCORPORATED WITHIN GUTTER.

APPROVED BY: *Manar Nashif*  
 CHIEF ENGINEERING OFFICER  
 DATE: 03/01/2024

REVISIONS	
DATE	DESCRIPTION
03-01-2024	REMOVED CONCRETE GUTTER OVERLAY DETAIL
03-01-2023	REVISED NOTE 10 AND USAGE OF CONCRETE CURB, TYPE C
03-01-2022	ADDED NEW G-2N & G-3N DETAILS
	REVISED CONC. GUTTER OVERLAY

**GUTTER AND CURB DETAILS**

VERSION: 2024-03	STANDARD: B1-12	SHEET: 1 OF 3
------------------	-----------------	---------------

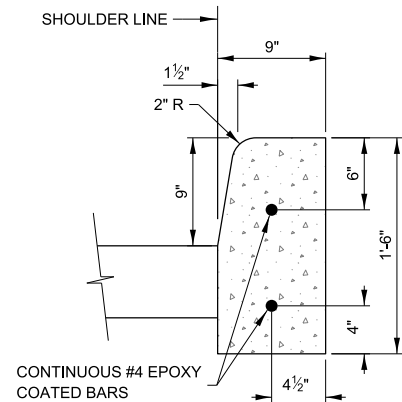

ADJACENT TO FLEXIBLE PAVEMENT

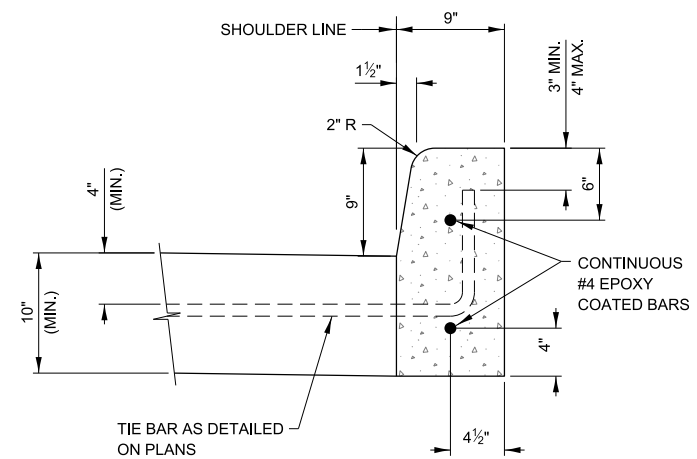

ADJACENT TO PCC PAVEMENT

**CONCRETE CURB, TYPE C**  
(SEE NOTE 1)

**NOTES:**

1. CONCRETE CURB, TYPE C SHALL ONLY BE USED ALONG PLAZA PARKING AREAS, AT MAINTENANCE FACILITIES, OR IN CONJUNCTION WITH GUARDRAIL ON THE TAPERING APPROACH TO A NON-AET PLAZA.
2. SEE SHEET 1 OF THIS SERIES FOR ADDITIONAL NOTES.

APPROVED BY: *Manar Nashif*  
CHIEF ENGINEERING OFFICER  
 DATE: 03/01/2024



**GUTTER AND CURB DETAILS**

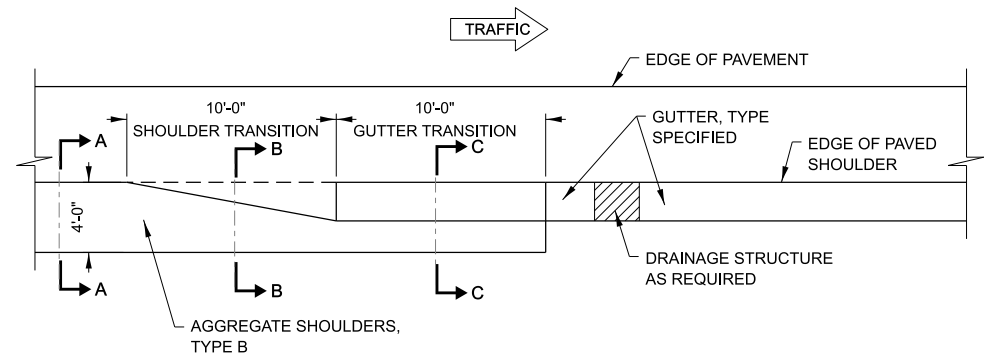

GUTTER TRANSITION TERMINATION

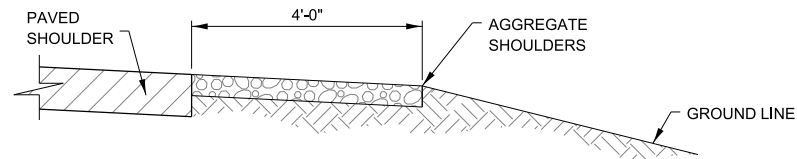

SECTION A-A

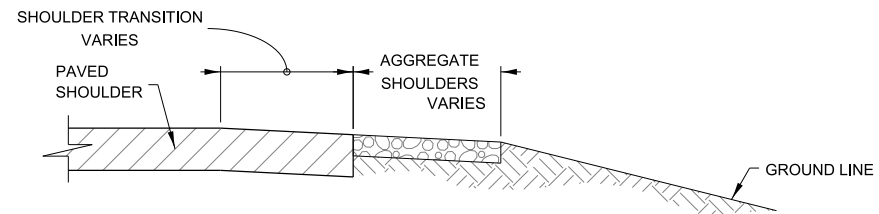

SECTION B-B  
ASPHALT SHOULDER TRANSITION

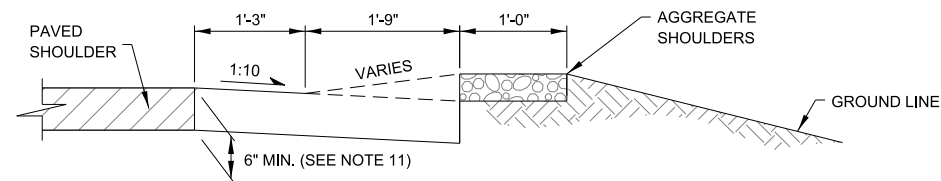

GUTTER, TYPE G-3 TRANSITION

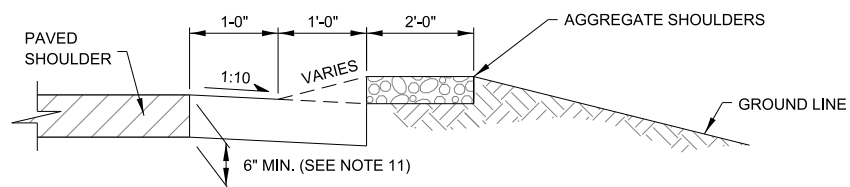

GUTTER, TYPE G-2 TRANSITION  
SECTION C-C

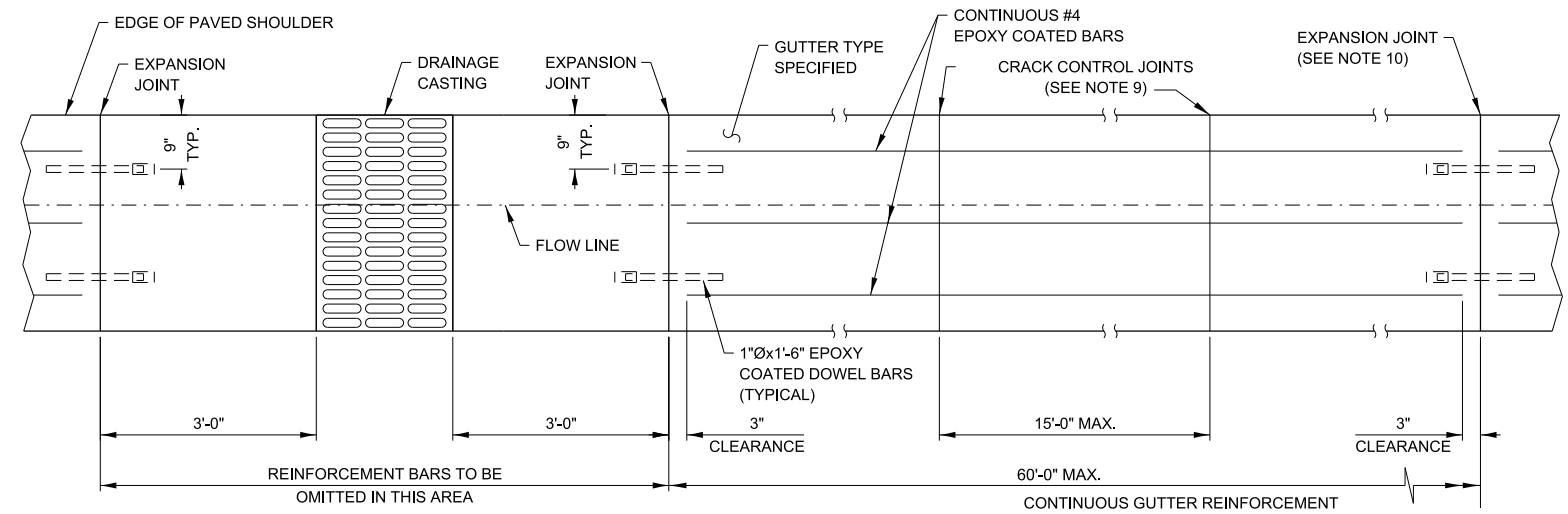

PLAN  
GUTTER, TYPE G-2 OR GUTTER, TYPE G-3  
(GUTTER, TYPE G-3 SHOWN)

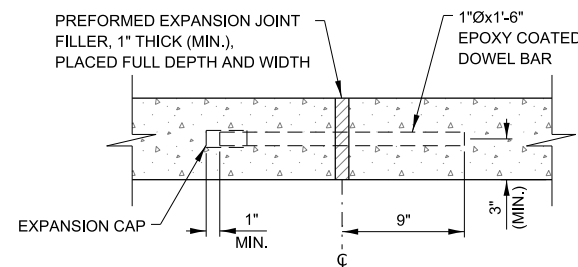

EXPANSION JOINT

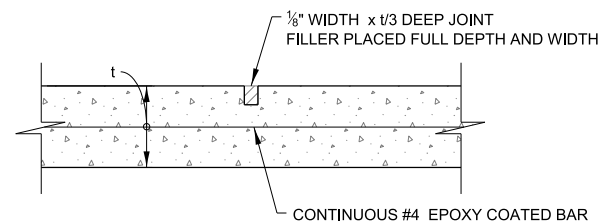

CRACK CONTROL JOINT

CONTRACTION-CRACK CONTROL JOINTS  
GUTTER, TYPE SPECIFIED

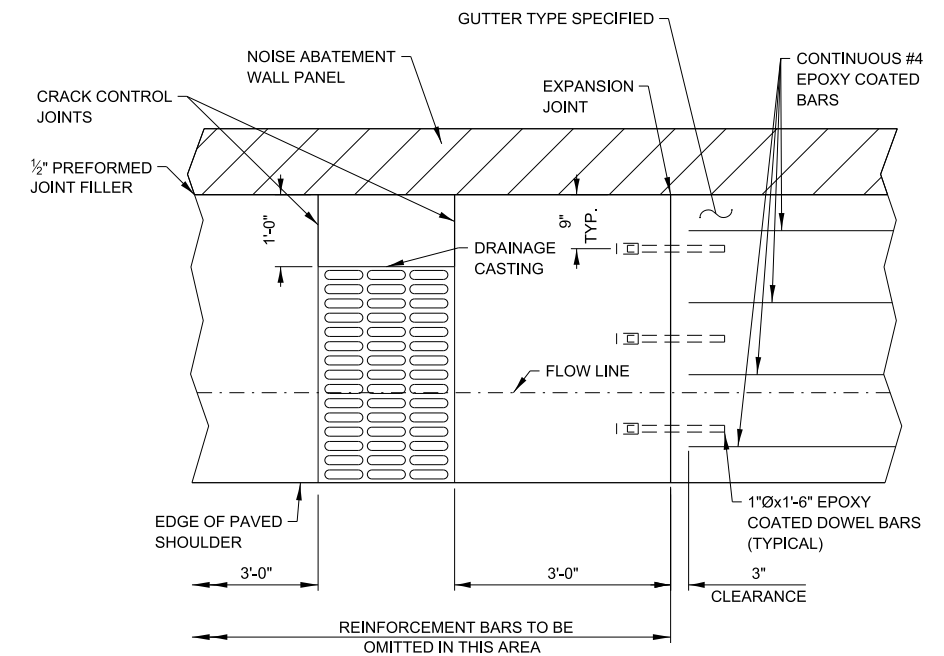

PLAN  
GUTTER, TYPE G-2N OR GUTTER, TYPE G-3N  
(GUTTER, TYPE G-3N SHOWN)

NOTE:  
SEE SHEET 1 OF THIS SERIES FOR NOTES.



GUTTER AND CURB DETAILS

VERSION: 2024-03 STANDARD: B1-12 SHEET: 3 OF 3

APPROVED BY: *Manar Nashif* DATE: 03/01/2024  
CHIEF ENGINEERING OFFICER

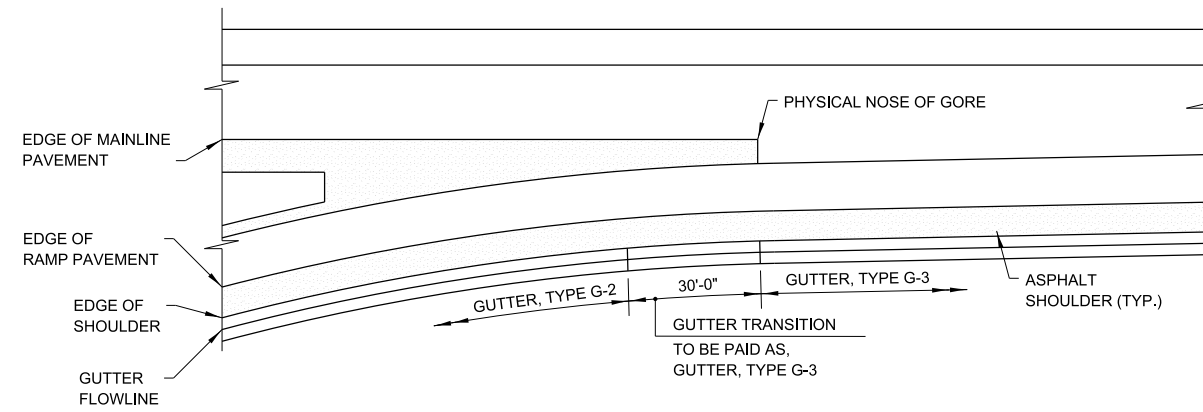

**GUTTER TRANSITION AT ENTRANCE RAMP TERMINALS**

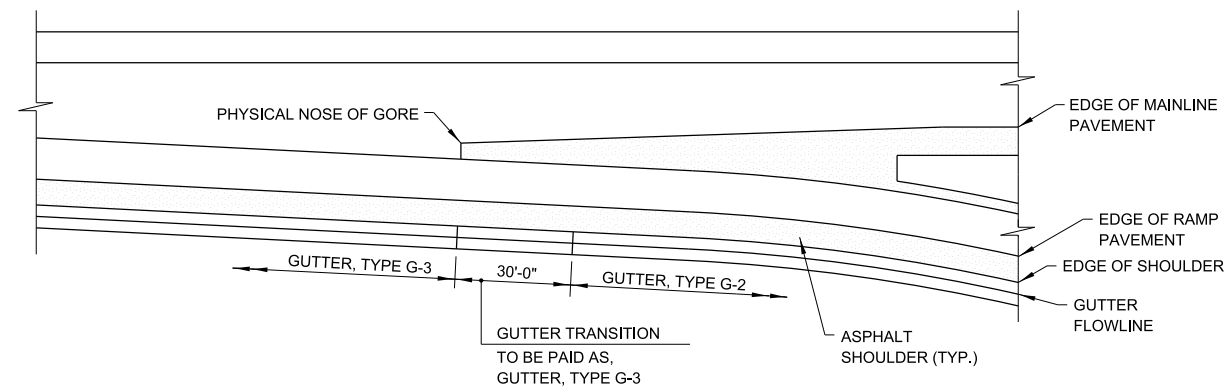

**GUTTER TRANSITION AT EXIT RAMP TERMINALS**

**GUTTER TRANSITION NOTES:**

1. PROVIDE 1" EXPANSION JOINT WITH PREFORMED JOINT FILLER BETWEEN TRANSITION SECTION AND WINGWALL, BARRIER, PARAPET OR NOISE ABATEMENT WALL.
2. SEE STANDARD B3 FOR GUTTER TRANSITIONS AT BRIDGE APPROACH.
3. ALL SLOPES ARE EXPRESSED AS UNITS OF VERTICAL DISPLACEMENT TO UNITS OF HORIZONTAL DISPLACEMENT (V:H).
4. REINFORCEMENT BARS SHALL BE ACCURATELY PLACED AND FIRMLY HELD AT THE POSITION USING EPOXY COATED CHAIRS. CHAIR SPACING SHALL NOT EXCEED 4'-0".
5. GUTTER REINFORCEMENT BARS SHALL BE PLACED 3" ABOVE BOTTOM OF GUTTER FOLLOWING SUBGRADE SLOPE.
6. CONTINUOUS #4 BARS SHALL BE LAPPED A MINIMUM OF 1'-1".
7. GUTTER DEPTH SHALL MATCH PAVED SHOULDER DEPTH.



REVISIONS	
DATE	DESCRIPTION
03-01-2023	ADDED G-3N & G-2N GUTTER TRANSITIONS, REMOVED GORE DIMENSIONS, RENAMED STANDARD
03-01-2019	TRANSITION SHT NOTED GUTTER DEPTH SHALL MATCH PAVED SHOULDER DEPTH
03-01-2018	REVISED NOTE

**GUTTER TRANSITION DETAILS**

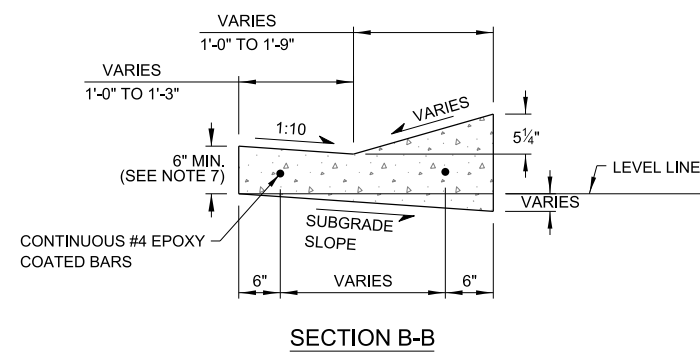
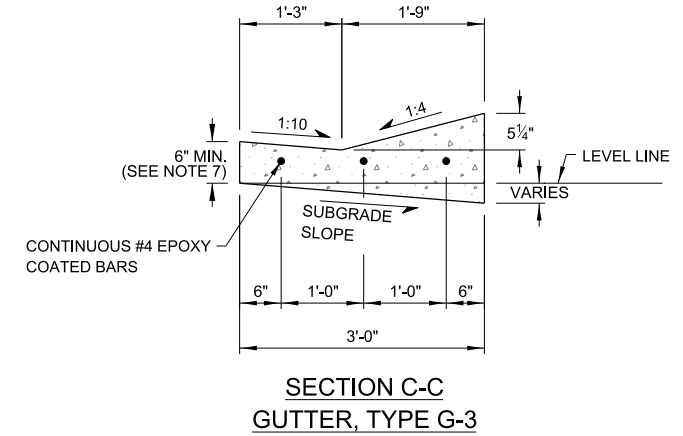
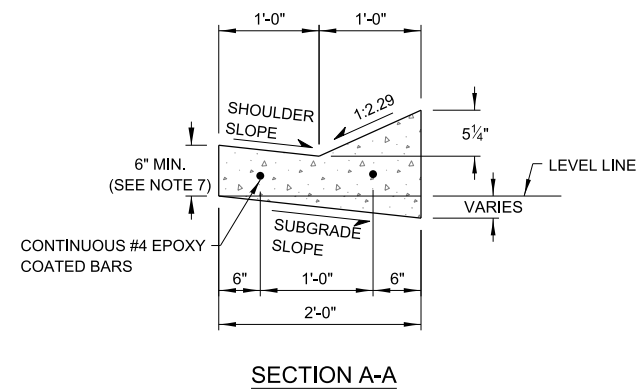
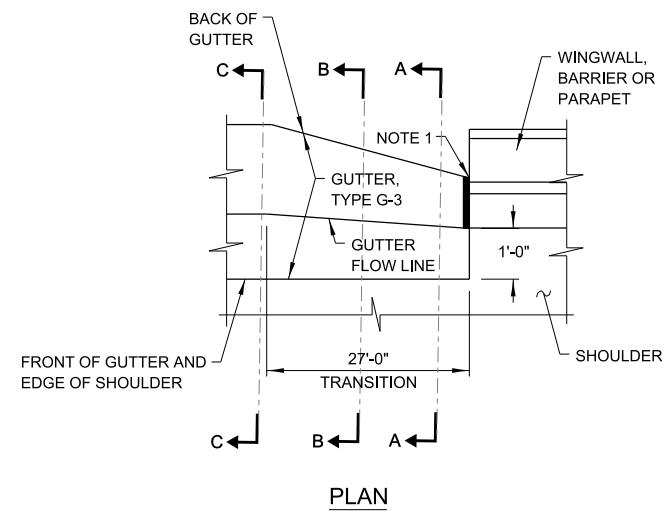

GUTTER, TYPE G-3 TRANSITION AT BRIDGE DEPARTURE

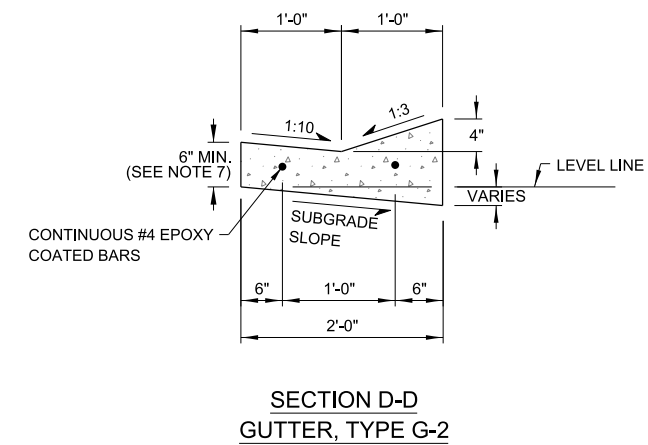
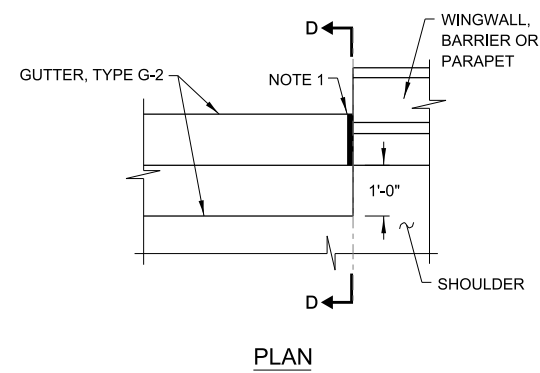

GUTTER, TYPE G-2 AT BRIDGE DEPARTURE

NOTE:  
SEE SHEET 1 OF THIS SERIES FOR NOTES.

APPROVED BY:  
*Manar Nashif*  
CHIEF ENGINEERING OFFICER

DATE:  
03/01/2023

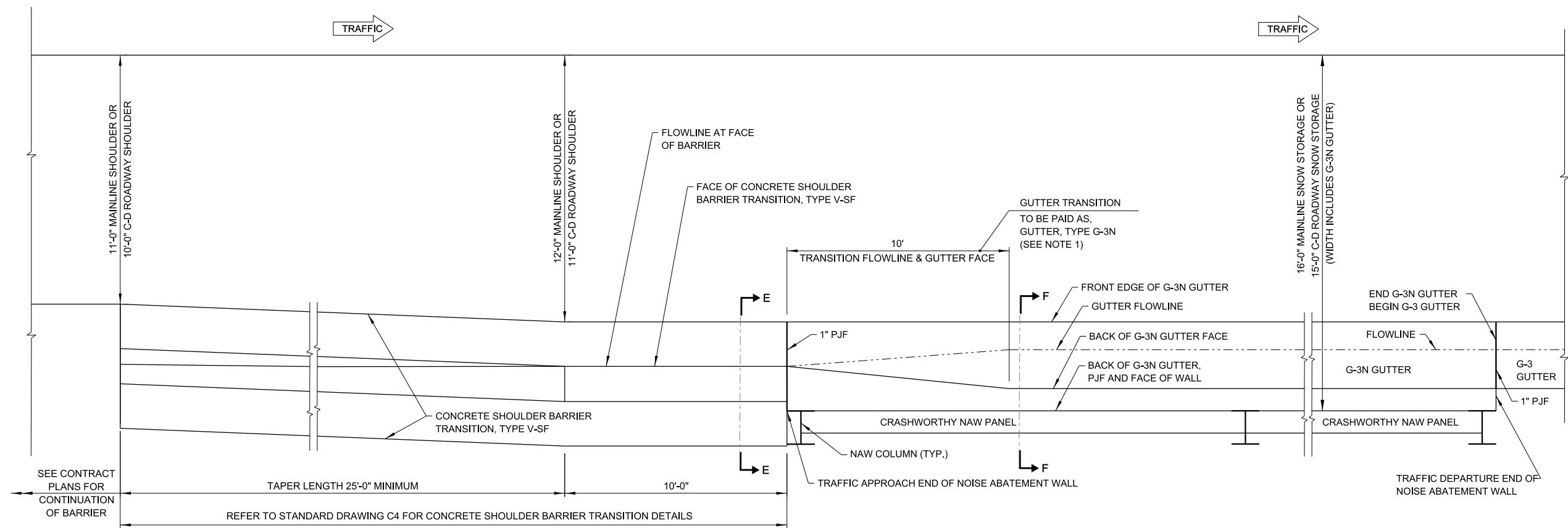

**G-3N GUTTER TRANSITION AT END OF CRASHWORTHY NOISE ABATEMENT WALL  
(USE ALONG MAINLINE AND C-D ROADWAYS)**

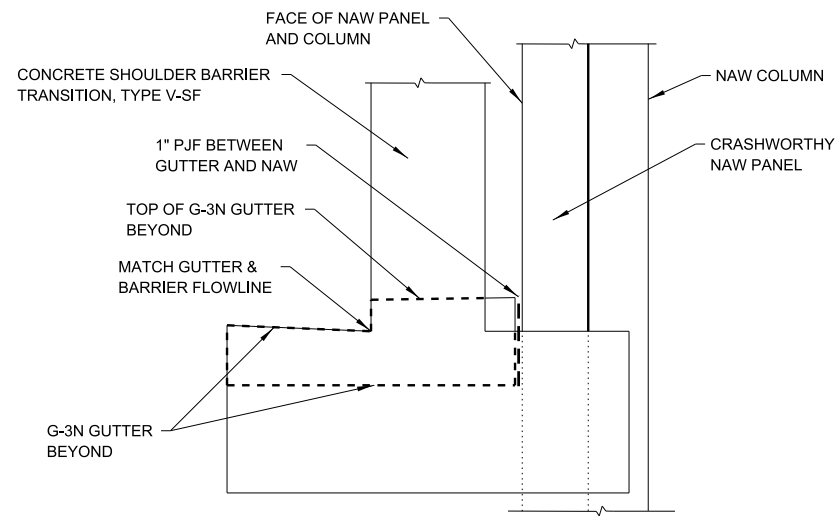

**SECTION E-E**

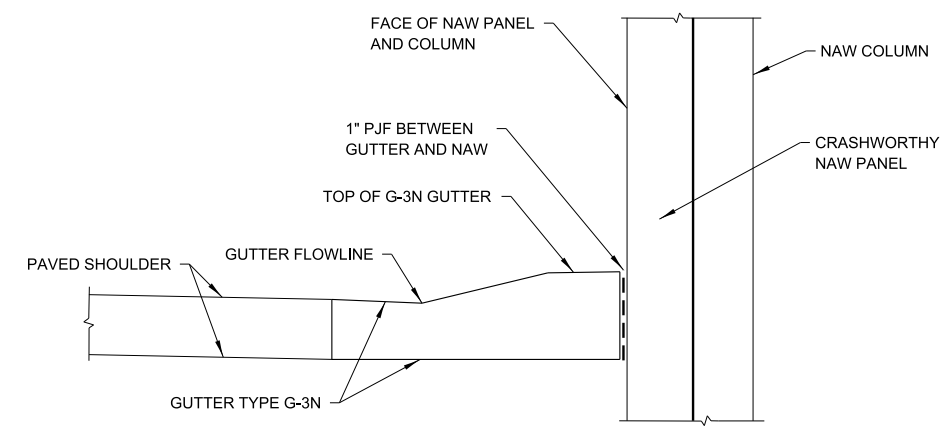

**SECTION F-F**

- NOTES:**
1. NO DRAINAGE STRUCTURES SHALL BE PLACED WITHIN THE GUTTER TRANSITION.
  2. SEE SHEET 1 OF THIS SERIES FOR ADDITIONAL NOTES.

APPROVED BY: *Manar Nashif*  
 CHIEF ENGINEERING OFFICER  
 DATE: 03/01/2023

  
**GUTTER TRANSITION DETAILS**  
 VERSION: 2023-03    STANDARD: B2-09    SHEET: 3 OF 4

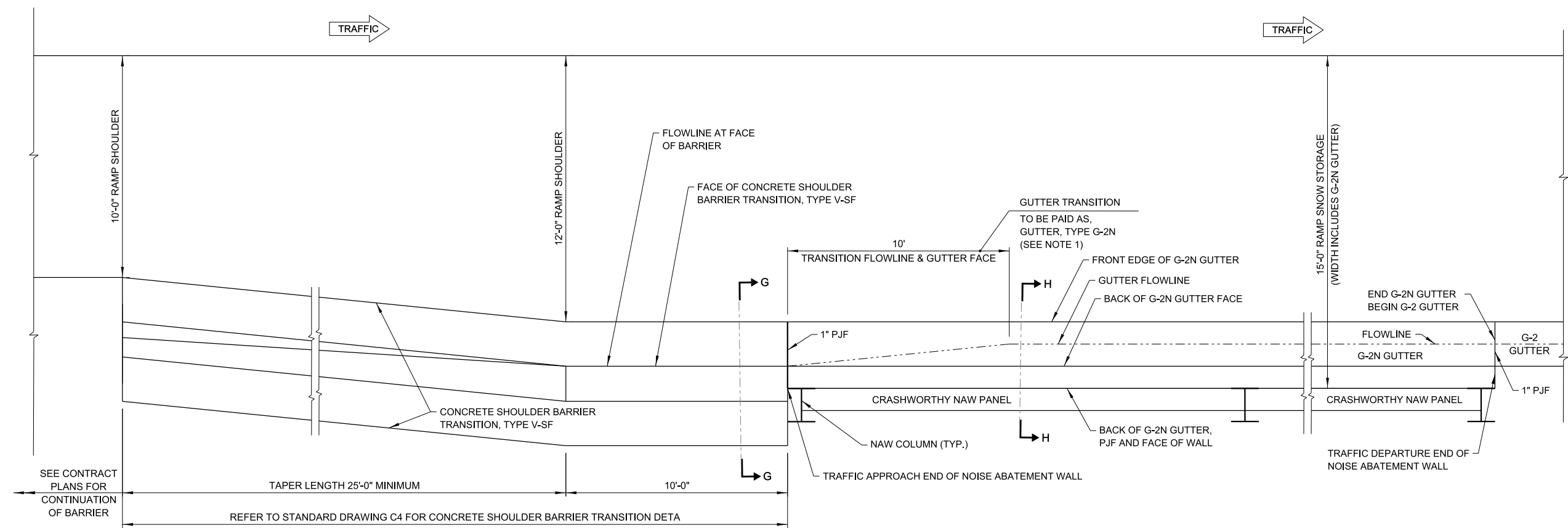

**G-2N GUTTER TRANSITION AT END OF CRASHWORTHY NOISE ABATEMENT WALL  
(USE ALONG RAMPS)**

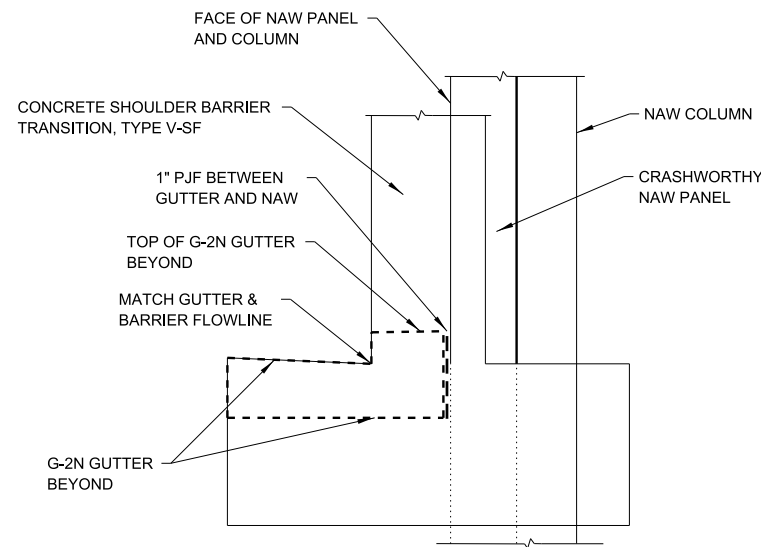

**SECTION G-G**

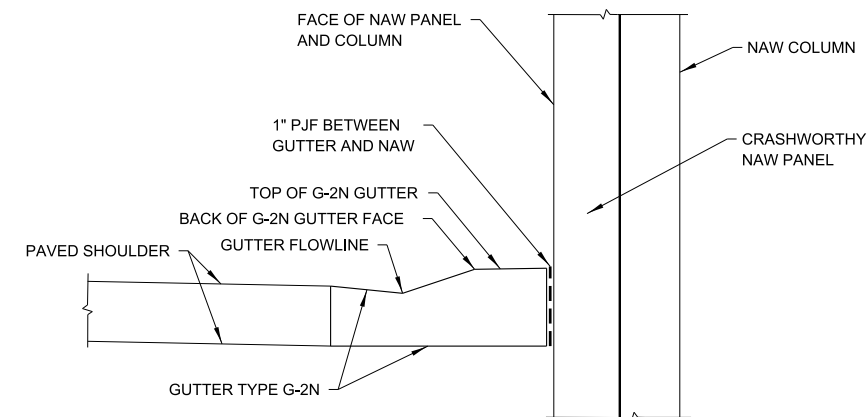

**SECTION H-H**

- NOTES:**
- NO DRAINAGE STRUCTURES SHALL BE PLACED WITHIN THE GUTTER TRANSITION.
  - SEE SHEET 1 OF THIS SERIES FOR ADDITIONAL NOTES.

APPROVED BY: *Manar Nashif*  
 CHIEF ENGINEERING OFFICER

DATE: 03/01/2023

**GUTTER TRANSITION DETAILS**

VERSION: 2023-03	STANDARD: B2-09	SHEET: 4 OF 4
---------------------	--------------------	------------------

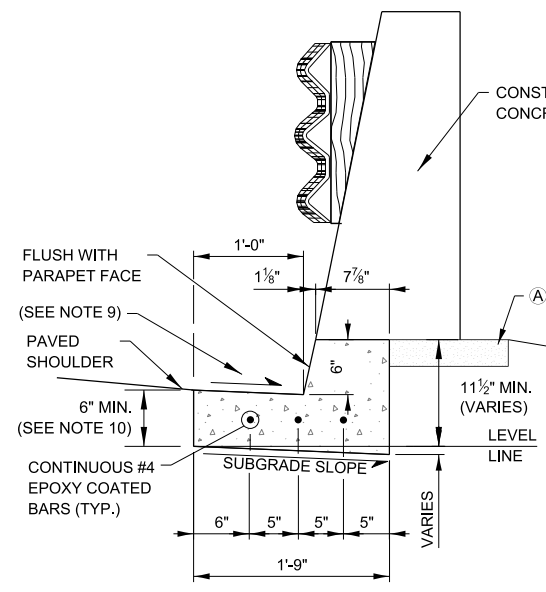
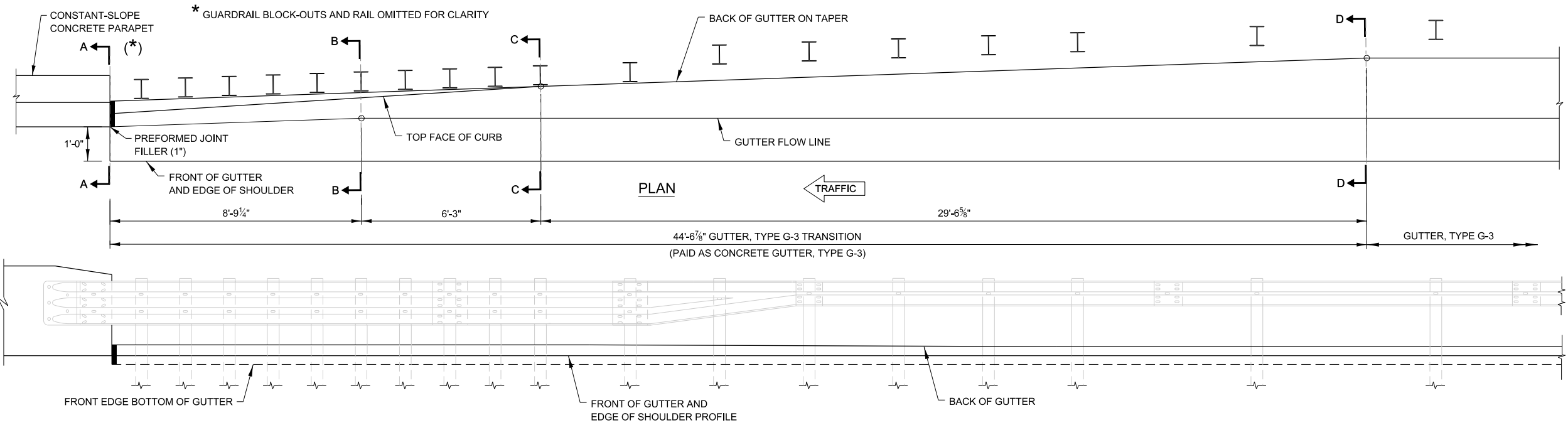

G-3 SECTION A-A  
AT CONCRETE PARAPET (SEE NOTE 7)

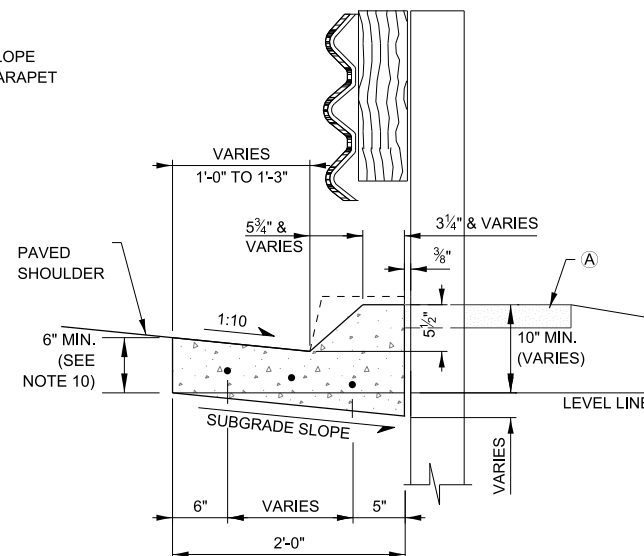

G-3 SECTION B-B  
8'-9 1/4" FROM PARAPET

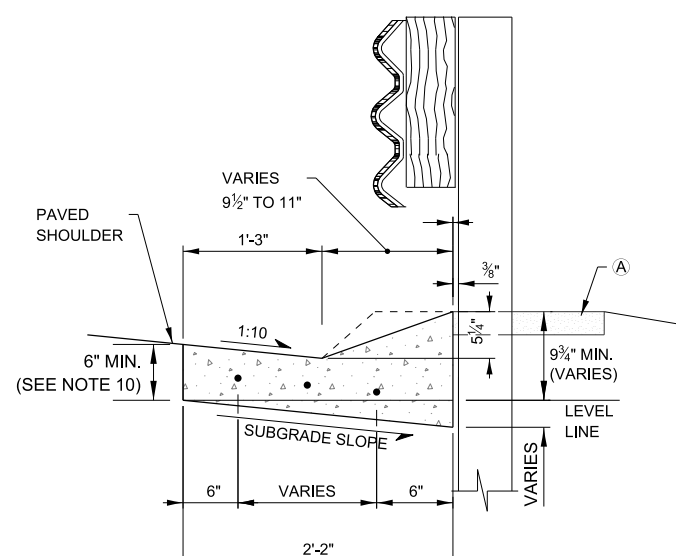

G-3 SECTION C-C  
15'-0 1/4" FROM PARAPET

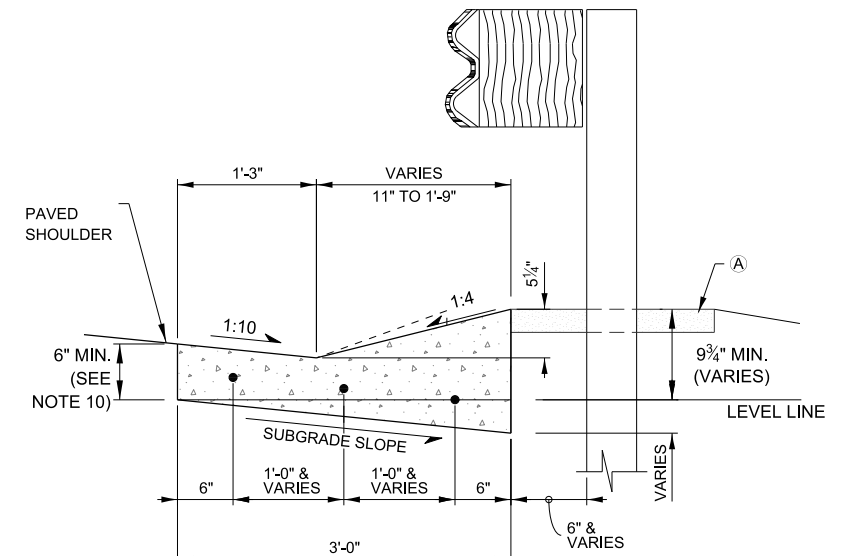

G-3 SECTION D-D  
44'-6 7/8" FROM PARAPET

GUTTER, TYPE G-3 TRANSITION AT TRAFFIC BARRIER TERMINAL, TYPE T6 TO CONSTANT-SLOPE CONCRETE PARAPET

GUTTER TRANSITION NOTES:

- SLOPE TO MATCH ADJACENT SHOULDER SLOPE.
- PROVIDE 1" EXPANSION JOINT WITH PREFORMED JOINT FILLER BETWEEN TRANSITION SECTION AND WINGWALL OR BARRIER WALL.
- INSTALLATION ON CURVED WINGWALLS SIMILAR.
- FOR DETAILS OF TRAFFIC BARRIER TERMINAL, TYPE T6, SEE ILLINOIS TOLLWAY STANDARD C9.
- GUTTER TRANSITIONS SHALL BE CONSTRUCTED TO FIT THE STANDARD LOCATION OF THE TRAFFIC BARRIER TERMINAL, TYPE T6.
- ALL SLOPES ARE EXPRESSED AS UNITS OF VERTICAL DISPLACEMENT TO UNITS OF HORIZONTAL DISPLACEMENT (V:H).
- GUTTER SECTION SHOWN AT BARRIER WALL SHALL MATCH PROFILE AND VERTICAL FACE OF BARRIER. MODIFY GUTTER FACE TO MATCH OTHER BARRIER/PARAPET PROFILES.
- CONTINUOUS #4 BARS SHALL BE LAPPED A MINIMUM OF 1'-1".
- MATCH SHOULDER SLOPE IN FRONT OF PARAPET OR BARRIER.
- GUTTER DEPTH SHALL MATCH PAVED SHOULDER DEPTH.

LEGEND

Ⓐ AGGREGATE SHOULDERS SPECIAL, TYPE C

APPROVED BY: *Manar Nashif*  
CHIEF ENGINEERING OFFICER  
DATE: 03/01/2024

REVISIONS	
DATE	DESCRIPTION
03-01-2024	ADDED NEW SHEET (4 OF 7)
03-15-2023	REVISED GUTTER TRANSITION LENGTH AND TAPER
03-01-2019	ADDED PG 1, 2 & 3 CONSTANT-SLOPE BARRIER & NOTE 10 (GUTTER DEPTH)
03-01-2018	REVISED G-2 GUTTER SHAPE

**TYPE G-2/G-3 GUTTER TRANSITION AT TRAFFIC BARRIER TERMINAL, TYPE T6**

VERSION: 2024-03	STANDARD: B3-10	SHEET: 1 OF 7
------------------	-----------------	---------------

\* GUARDRAIL BLOCK-OUTS AND RAIL ARE OMITTED FOR CLARITY

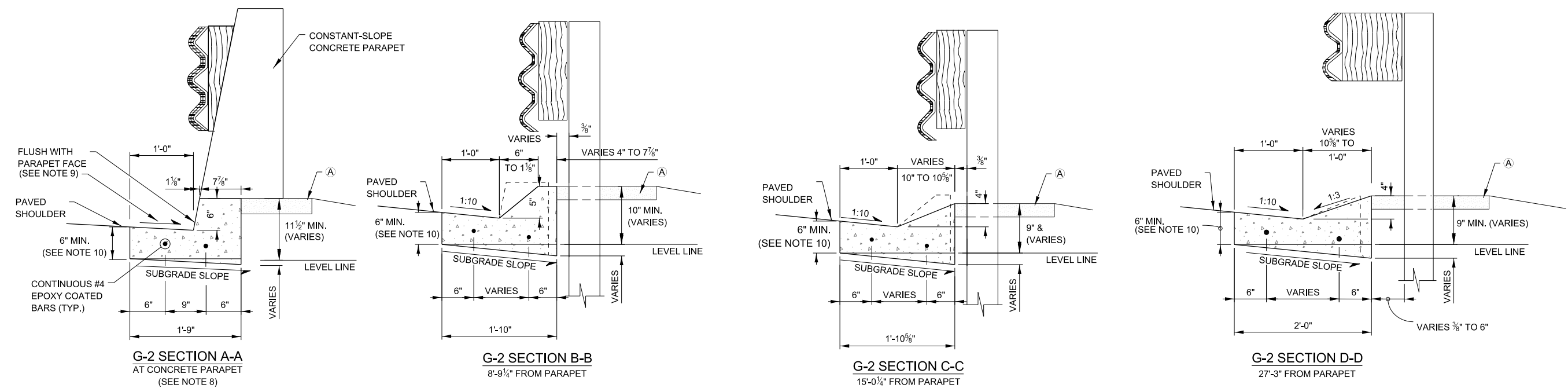
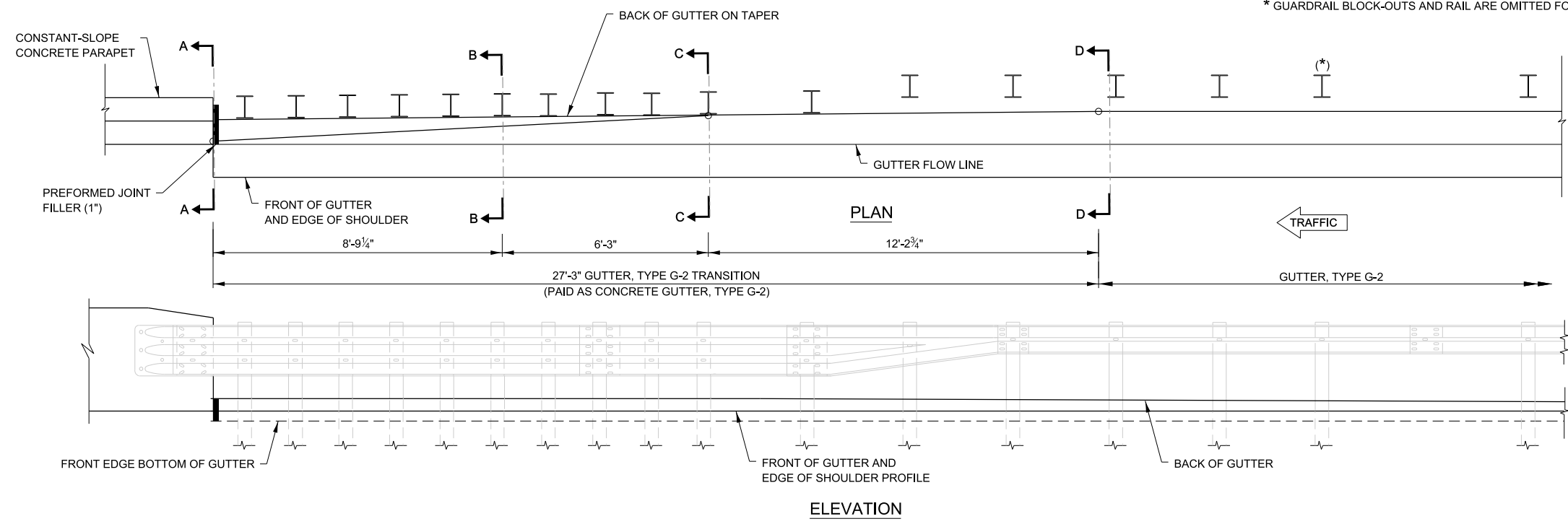

**GUTTER, TYPE G-2 TRANSITION AT TRAFFIC BARRIER TERMINAL, TYPE T6 TO CONSTANT-SLOPE CONCRETE PARAPET**

**LEGEND**  
 (A) AGGREGATE SHOULDERS SPECIAL, TYPE C

**NOTE:**  
 SEE SHEET 1 OF THIS SERIES FOR GUTTER TRANSITION NOTES.

APPROVED BY: *Manar Nashif*  
 CHIEF ENGINEERING OFFICER  
 DATE: 03/01/2024

**TYPE G-2/G-3 GUTTER TRANSITION AT TRAFFIC BARRIER TERMINAL, TYPE T6**

VERSION: 2024-03	STANDARD: B3-10	SHEET: 2 OF 7
---------------------	--------------------	------------------

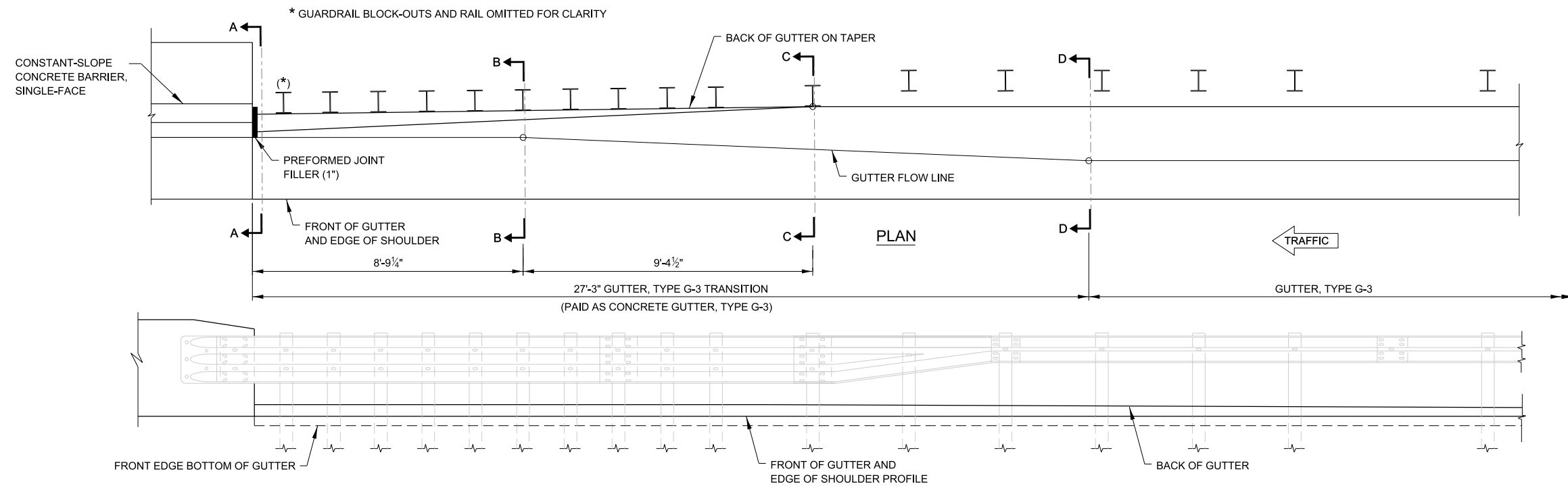

ELEVATION

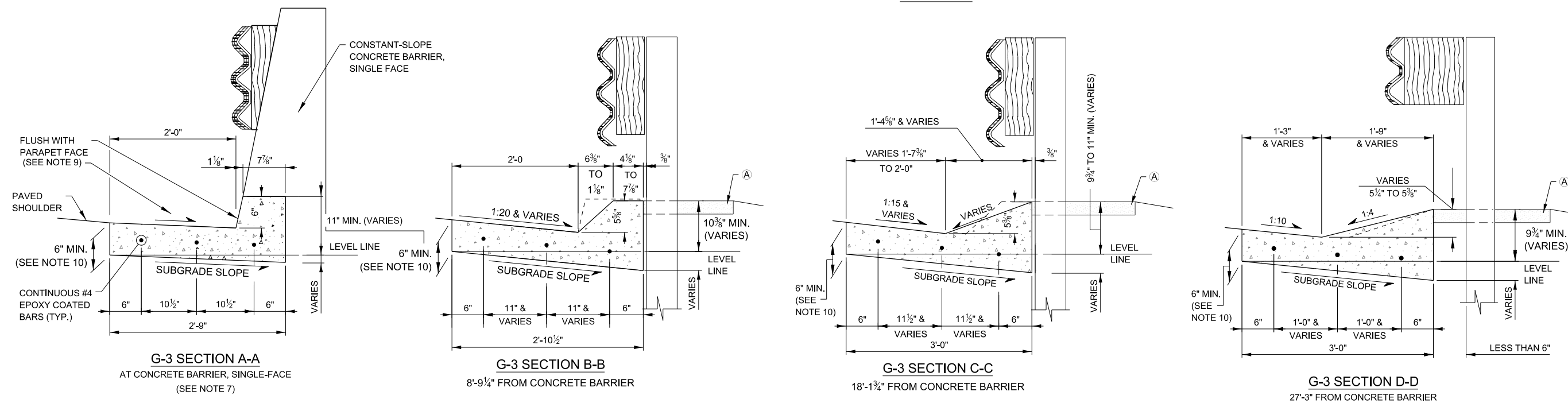

LEGEND:

(A) AGGREGATE SHOULDERS SPECIAL, TYPE C

GUTTER, TYPE G-3 TRANSITION AT TRAFFIC BARRIER TERMINAL, TYPE T6, TO CONSTANT-SLOPE CONCRETE BARRIER, SINGLE FACE

NOTE:  
SEE SHEET 1 OF THIS SERIES FOR GUTTER TRANSITION NOTES.



TYPE G-2/G-3 GUTTER TRANSITION AT TRAFFIC BARRIER TERMINAL, TYPE T6

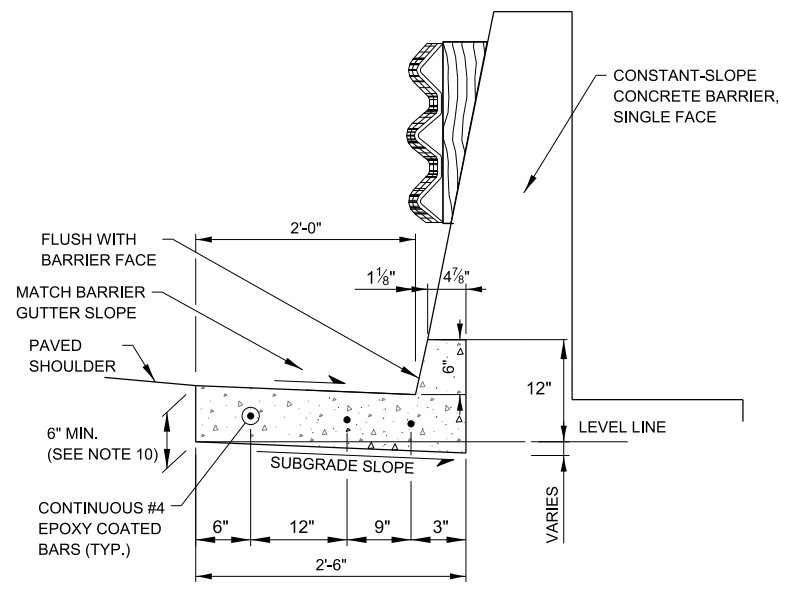
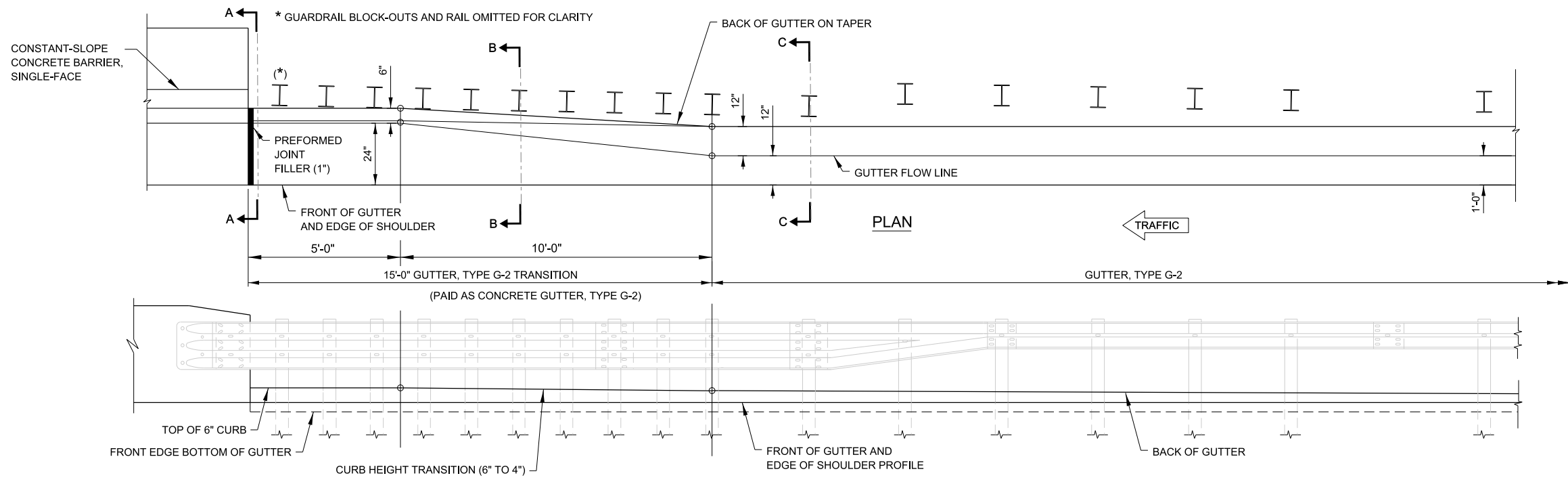

**G-2 SECTION A-A**  
AT CONCRETE BARRIER, SINGLE-FACE  
(SEE NOTE 7)

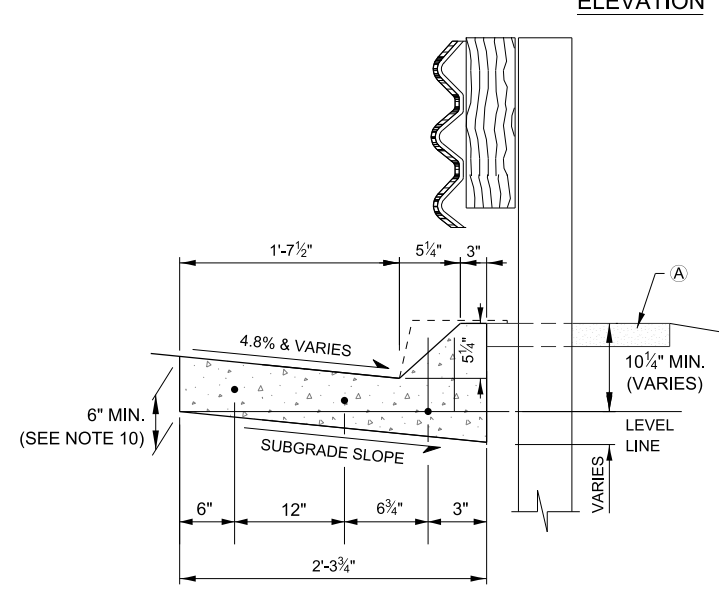

**G-2 SECTION B-B**  
8'-9 1/4" FROM CONCRETE BARRIER

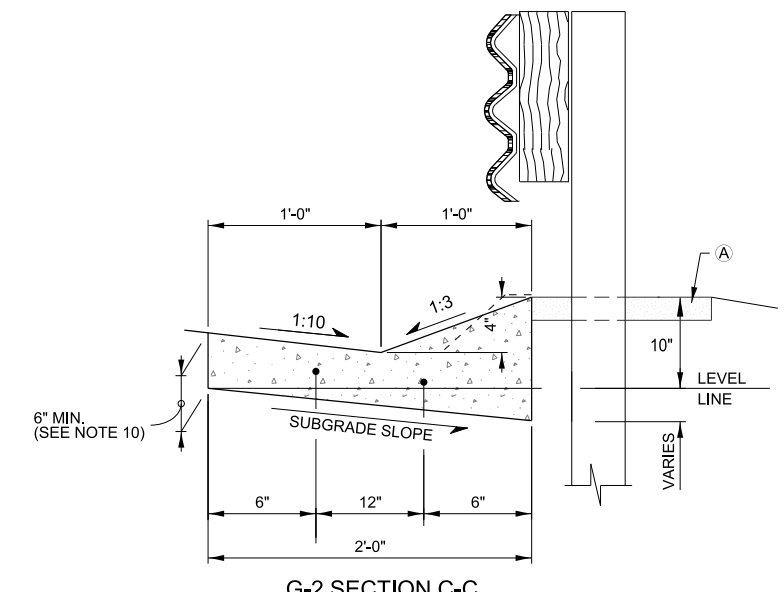

**G-2 SECTION C-C**  
18'-1 3/4" FROM CONCRETE BARRIER

**GUTTER, TYPE G-2 TRANSITION AT TRAFFIC BARRIER TERMINAL, TYPE T6,  
TO CONSTANT-SLOPE CONCRETE BARRIER, SINGLE FACE**

**LEGEND**

(A) AGGREGATE SHOULDERS SPECIAL, TYPE C

**NOTE:**  
SEE SHEET 1 OF THIS SERIES FOR GUTTER  
TRANSITION NOTES.

APPROVED BY: *Manar Nashif*  
CHIEF ENGINEERING OFFICER  
DATE: 03/01/2024

**TYPE G-2/G-3 GUTTER  
TRANSITION AT TRAFFIC  
BARRIER TERMINAL,  
TYPE T6**

VERSION: 2024-03	STANDARD: B3-10	SHEET: 4 OF 7
---------------------	--------------------	------------------

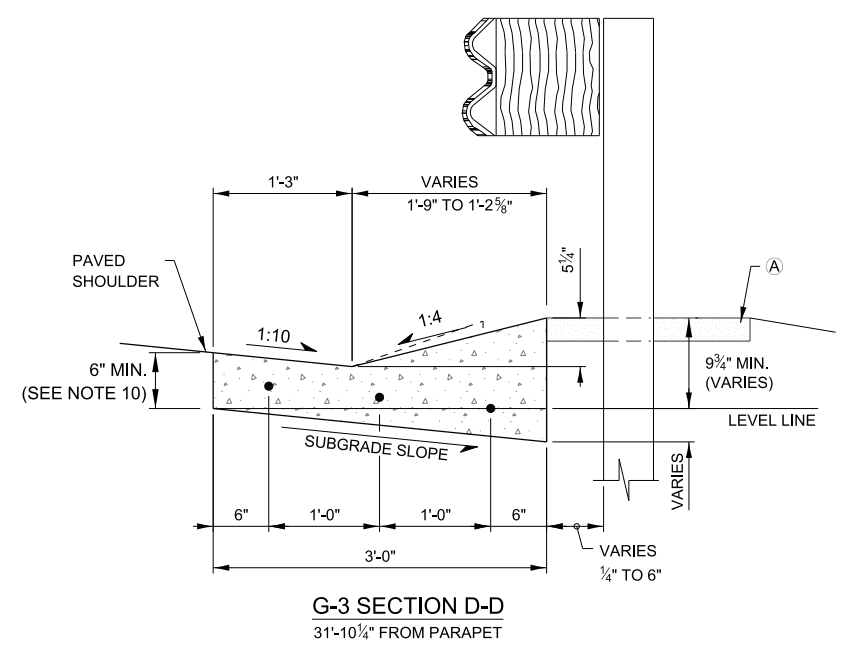
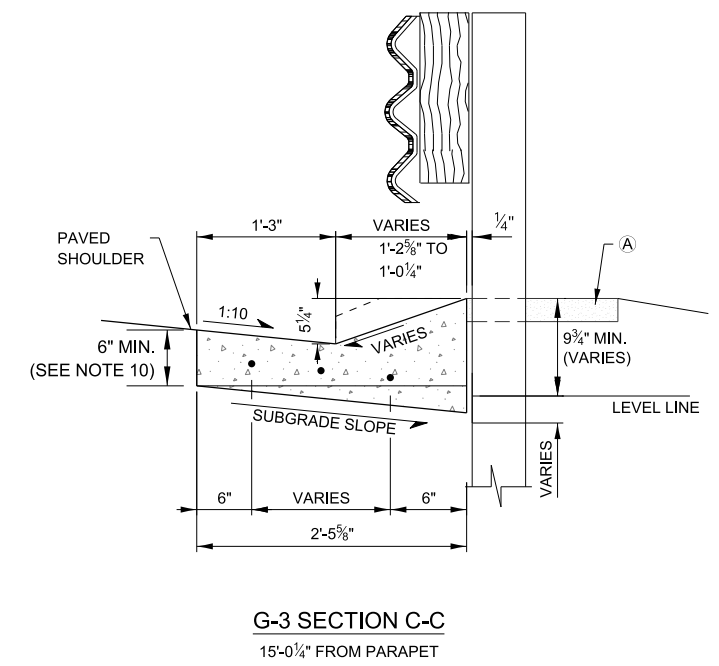
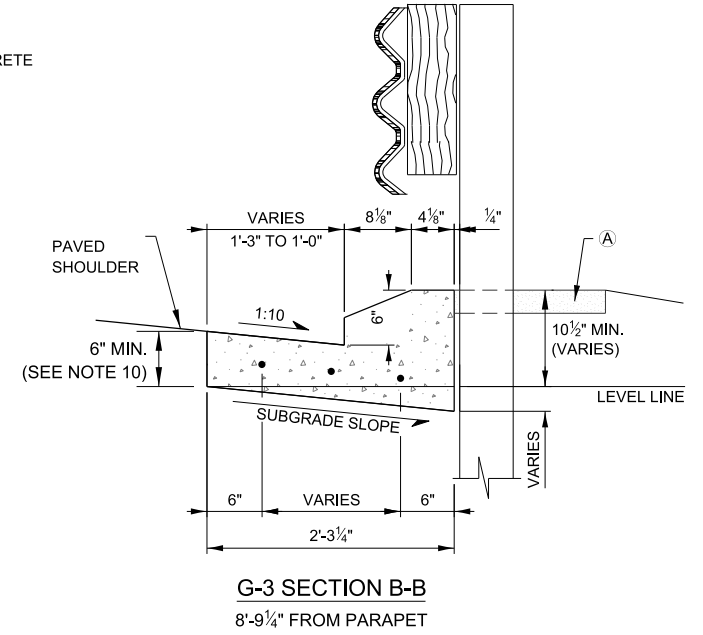
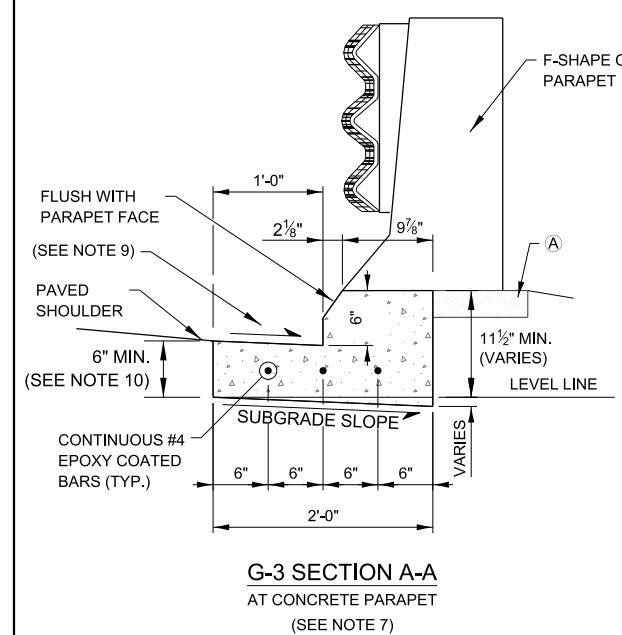
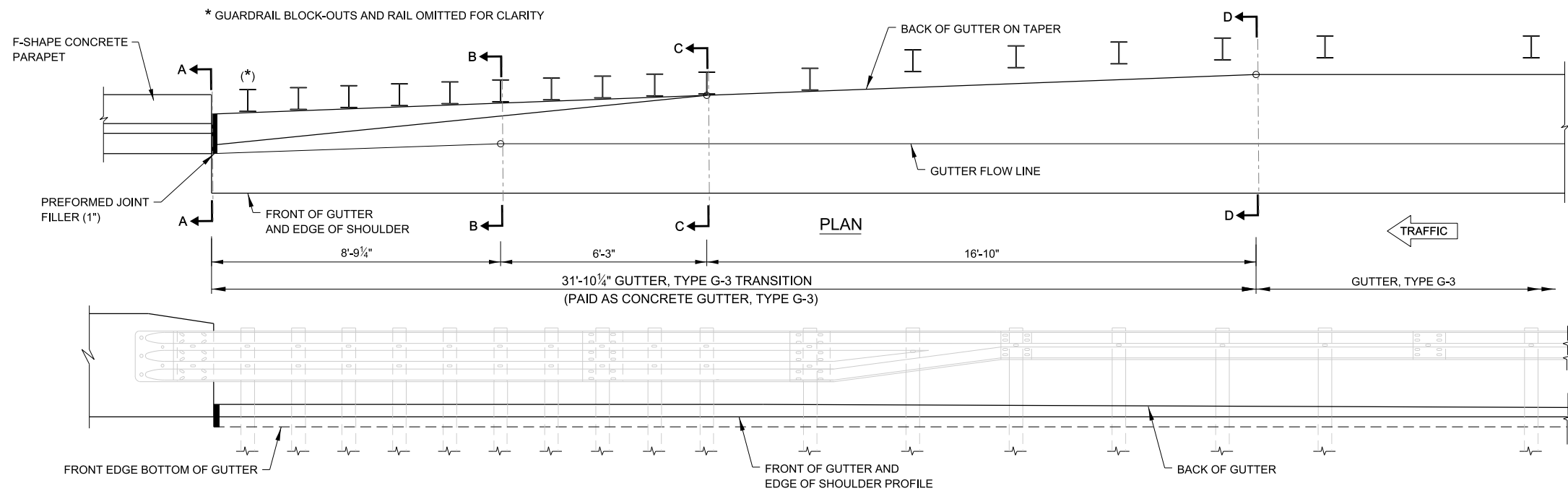

GUTTER, TYPE G-3 TRANSITION AT TRAFFIC BARRIER TERMINAL, TYPE T6 TO F-SHAPE CONCRETE PARAPET

NOTE:  
SEE SHEET 1 OF THIS SERIES FOR GUTTER  
TRANSITION NOTES.

APPROVED BY:  
*Manar Nashif*  
CHIEF ENGINEERING OFFICER

DATE:  
03/01/2024

TYPE G-2/G-3 GUTTER  
TRANSITION AT TRAFFIC  
BARRIER TERMINAL,  
TYPE T6

VERSION: 2024-03	STANDARD: B3-10	SHEET: 5 OF 7
---------------------	--------------------	------------------

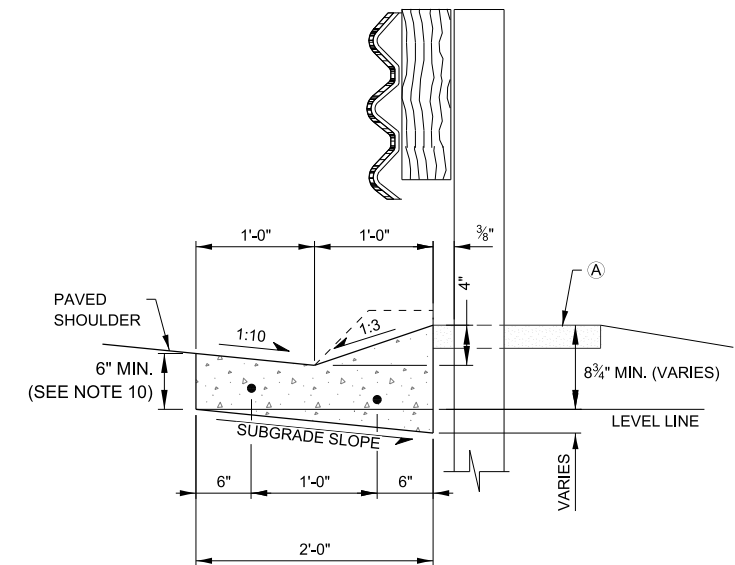
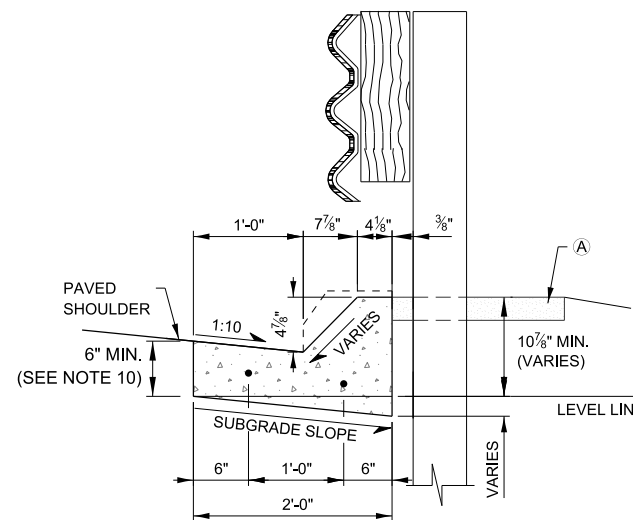
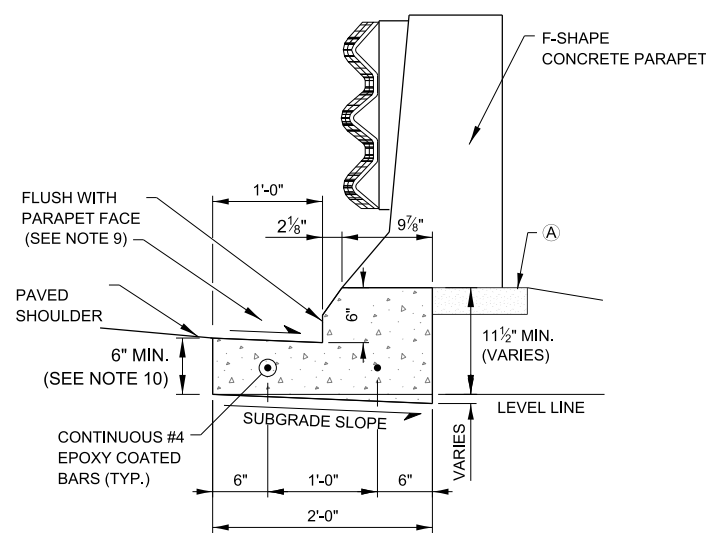
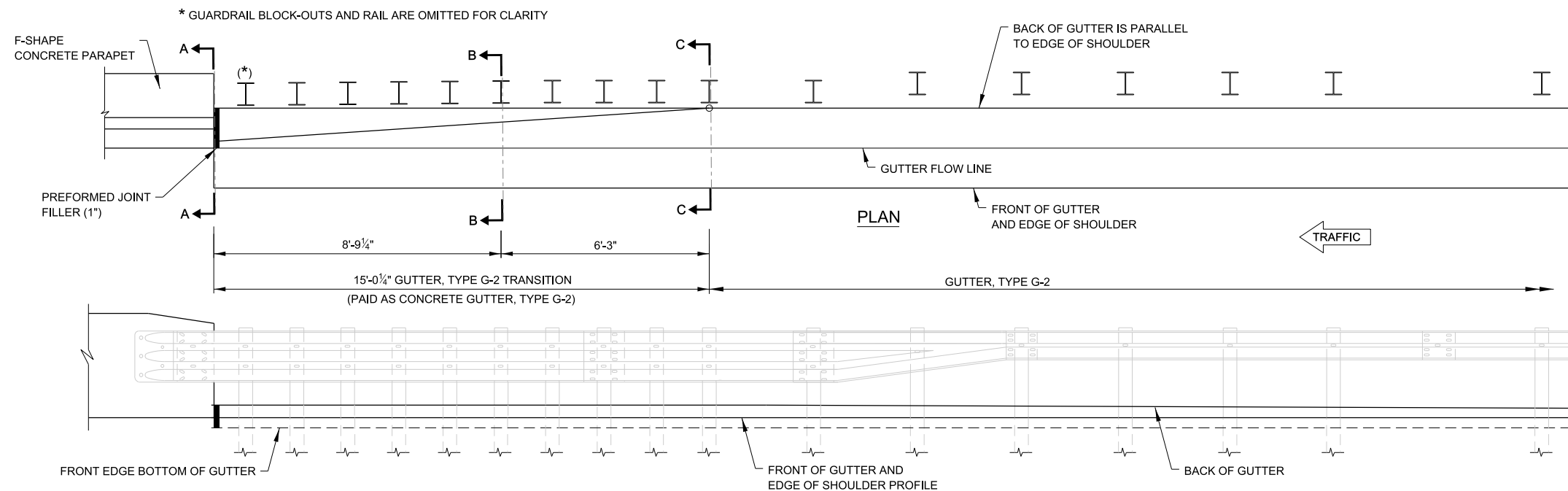

GUTTER, TYPE G-2 TRANSITION AT TRAFFIC BARRIER TERMINAL, TYPE T6  
TO F-SHAPE CONCRETE PARAPET

LEGEND

(A) AGGREGATE SHOULDERS SPECIAL, TYPE C

NOTE:  
SEE SHEET 1 OF THIS SERIES FOR GUTTER  
TRANSITION NOTES.

APPROVED BY: *Manar Nashif*  
CHIEF ENGINEERING OFFICER  
DATE: 03/01/2024

TYPE G-2/G-3 GUTTER  
TRANSITION AT TRAFFIC  
BARRIER TERMINAL,  
TYPE T6

VERSION: 2024-03	STANDARD: B3-10	SHEET: 6 OF 7
---------------------	--------------------	------------------

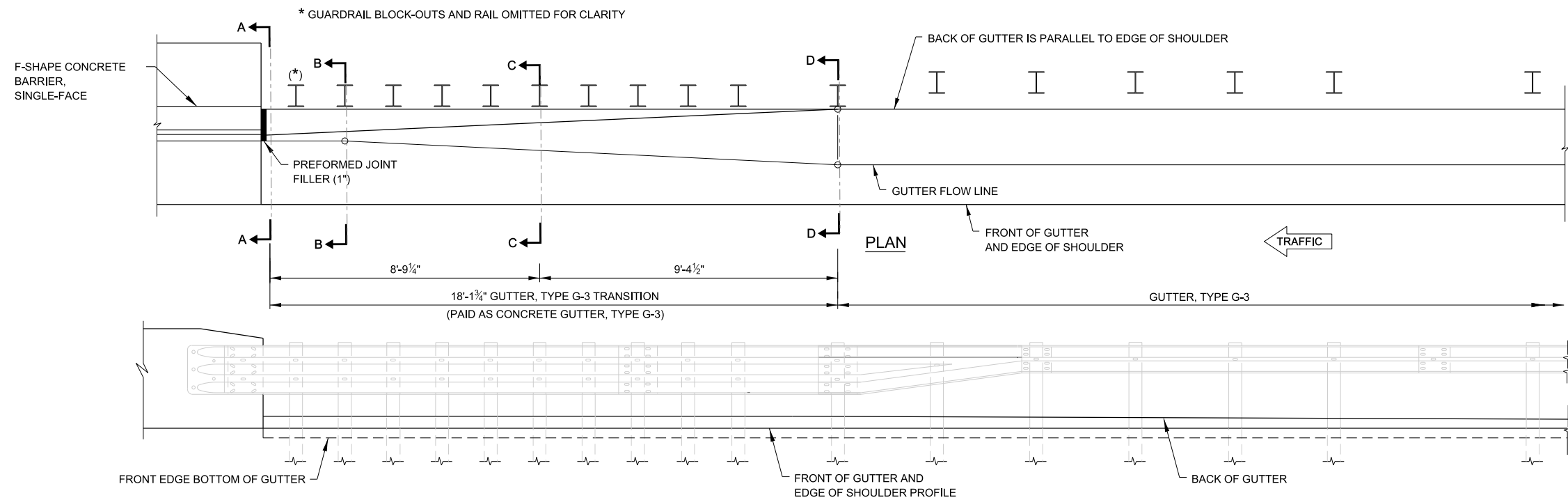

ELEVATION

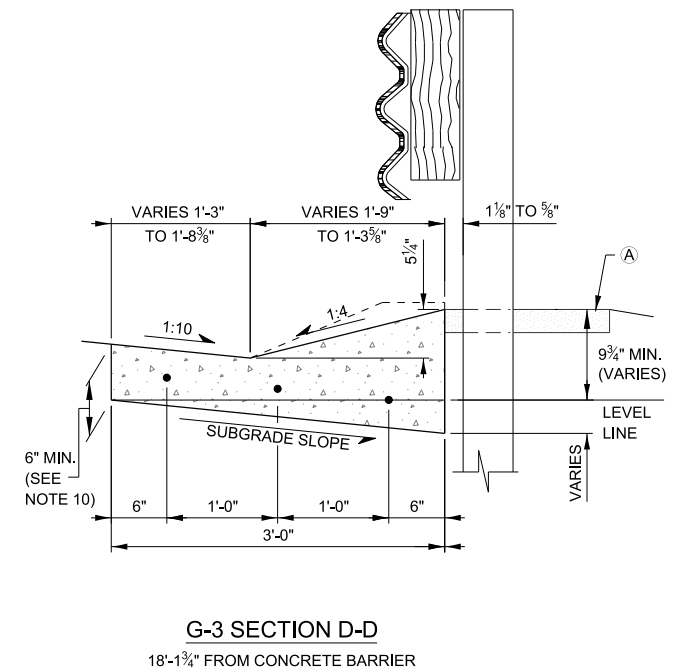
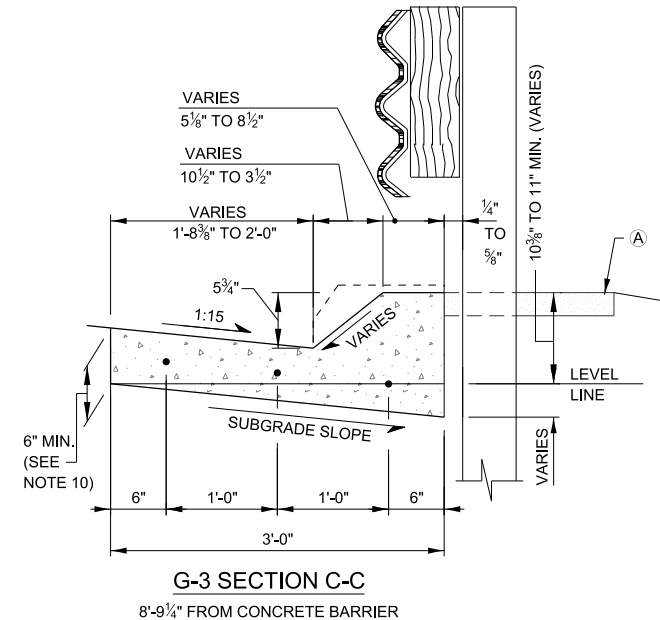
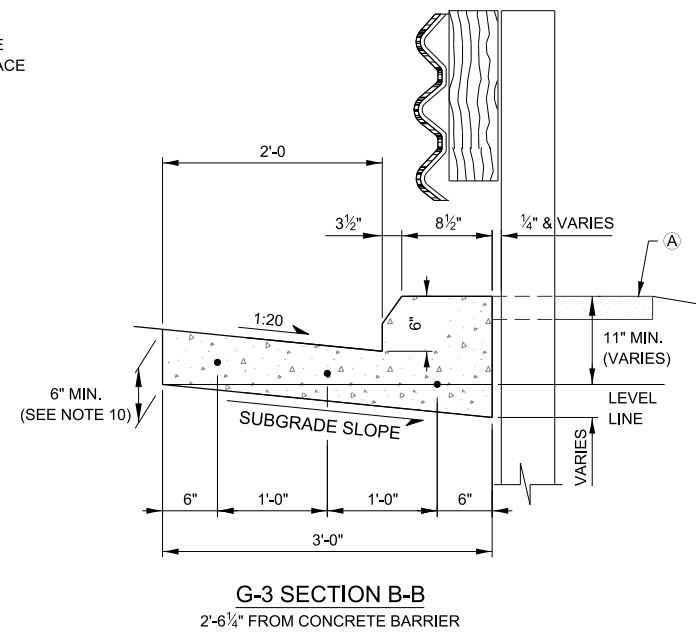
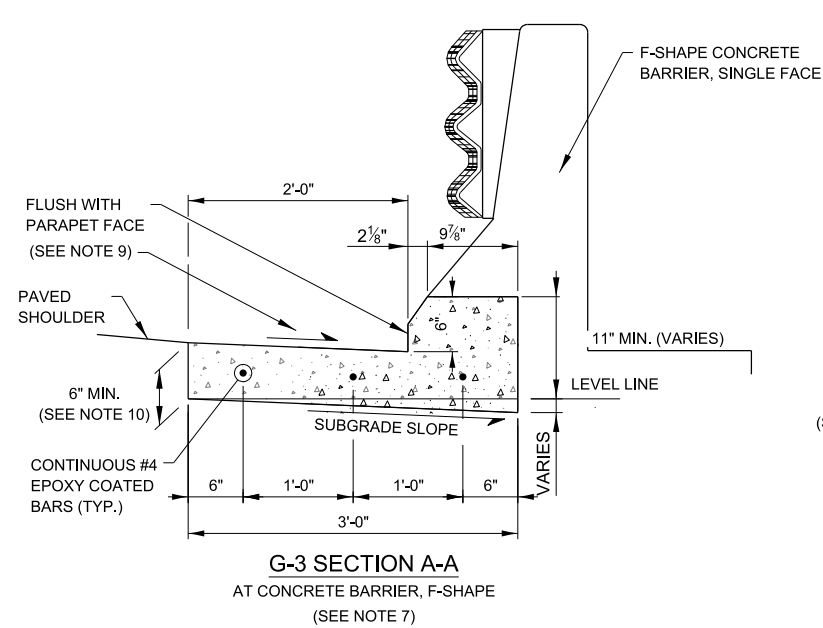

GUTTER, TYPE G-3 TRANSITION AT TRAFFIC BARRIER TERMINAL, TYPE T6, TO F-SHAPED CONCRETE BARRIER, SINGLE-FACE

LEGEND

(A) AGGREGATE SHOULDERS SPECIAL, TYPE C

NOTE:  
SEE SHEET 1 OF THIS SERIES FOR GUTTER TRANSITION NOTES.

APPROVED BY: *Manar Nashif*  
CHIEF ENGINEERING OFFICER

DATE: 03/01/2024

TYPE G-2/G-3 GUTTER TRANSITION AT TRAFFIC BARRIER TERMINAL, TYPE T6

VERSION: 2024-03	STANDARD: B3-10	SHEET: 7 OF 7
---------------------	--------------------	------------------

**CONCRETE FLUME**

**NOTES:**

1. CONCRETE FLUMES SHALL BE CONSTRUCTED FLUSH WITH THE ADJACENT EXISTING OR PROPOSED SURFACES.
2. CLASS SI CONCRETE SHALL BE USED THROUGHOUT.
3. WELDED WIRE REINFORCEMENT SHALL BE EPOXY COATED 6x6 W4xW4, 58 LBS. PER 100 SQ. FT.
4. #4 EPOXY COATED TIE BARS 2'-6" LONG AT 12" O/C SHALL BE PROVIDED AT ALL CONSTRUCTION JOINTS.
5. EPOXY COATED EXPANDED METAL FABRIC OF EQUIVALENT STRENGTH MAY BE USED IN LIEU OF WELDED WIRE REINFORCEMENT SUBJECT TO ENGINEER'S APPROVAL.
6. THE LOCATION OF THE ANCHOR WALL MAY BE ADJUSTED AS DIRECTED BY THE ENGINEER.
7. THE MATERIALS AND CONSTRUCTION OF THE CONCRETE FLUME SHALL CONFORM TO THE APPLICABLE PORTIONS OF THE STANDARD SPECIFICATIONS.

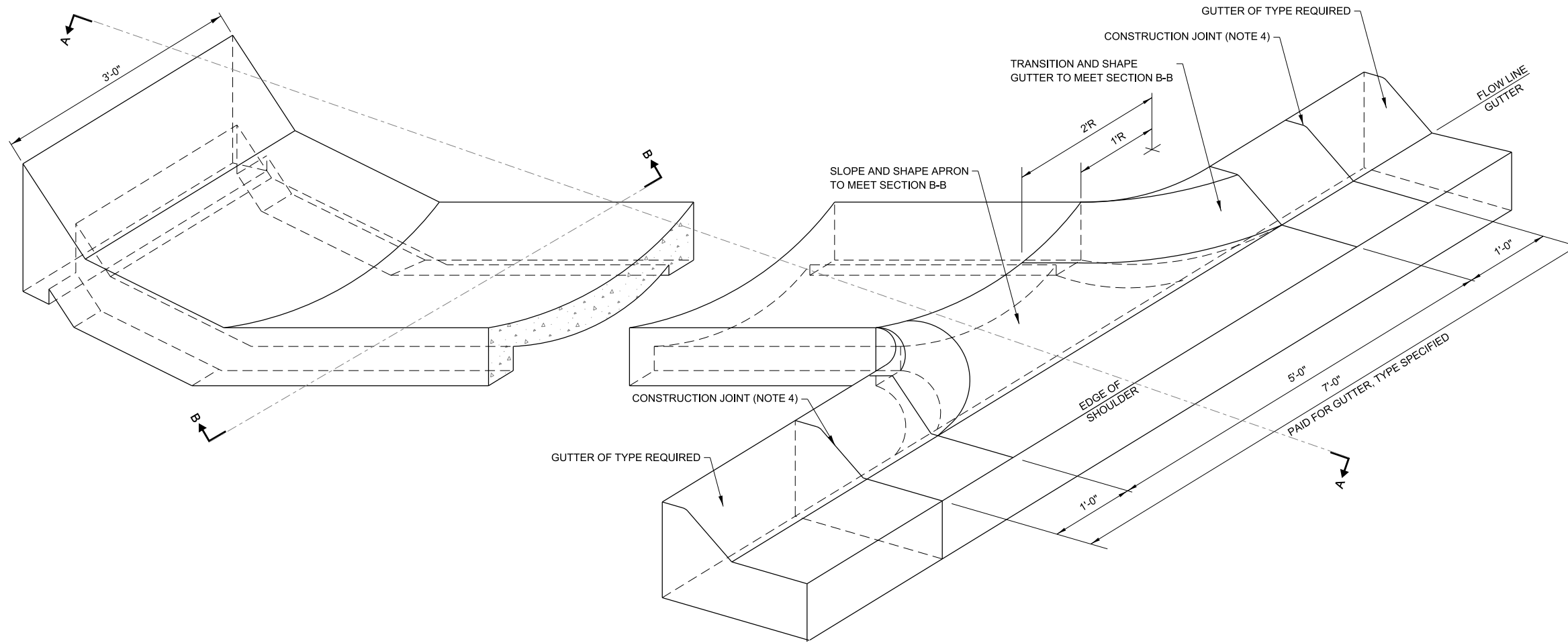

**PLAN**

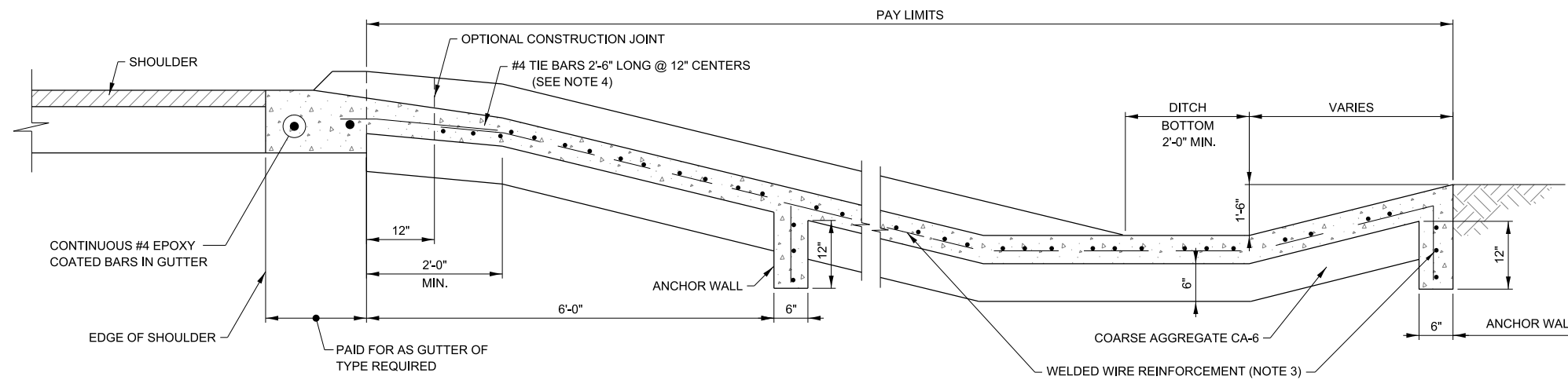

**SECTION A-A  
ADJACENT TO GUTTER**

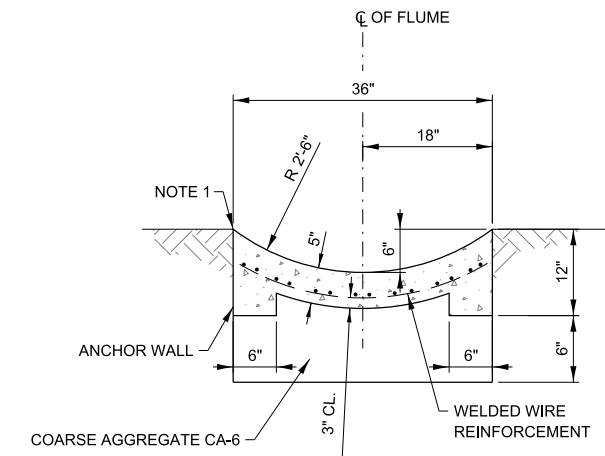

**NOTE:**  
0.62 C.Y. CONCRETE / L.F.

**SECTION B-B**



**CONCRETE FLUME DETAILS**

REVISIONS	
DATE	DESCRIPTION
03-01-2018	REVISED SECTION A-A TO INCLUDE COARSE AGGREGATE. NOTE 8 WAS REMOVED.
03-31-2016	CHANGED TERMINOLOGY TO WELDED WIRE REINFORCEMENT
03-11-2015	DELETED CURB SECTION

VERSION: 2018-03      STANDARD: B5-04      SHEET: 1 OF 1

APPROVED BY:

DATE:

*Paul Kovacs*  
CHIEF ENGINEERING OFFICER

03/01/2018

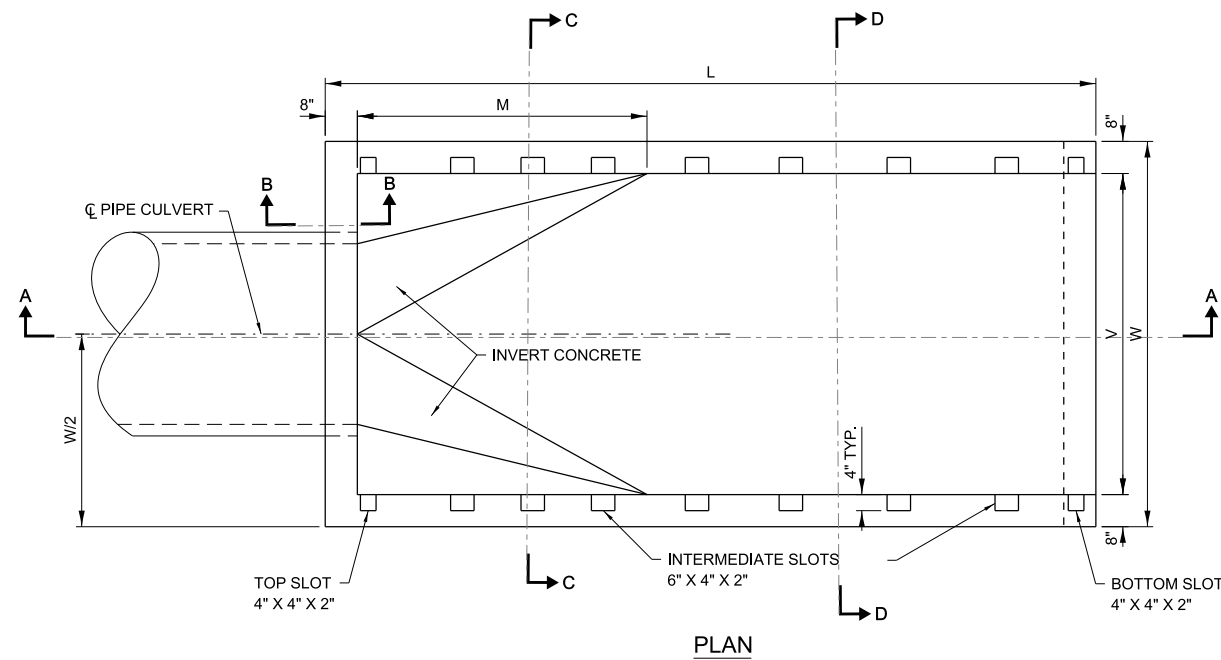

PLAN

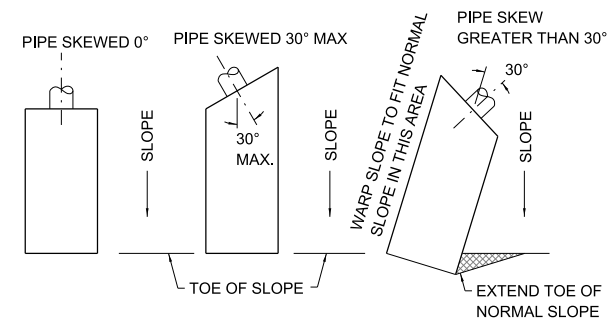

PLAN VIEW OF STRUCTURE LOCATIONS

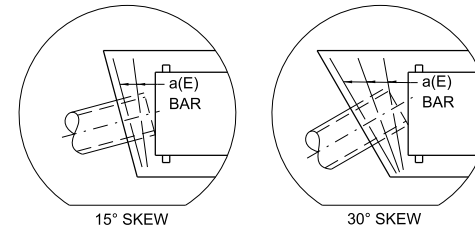

FLARED BAR DETAILS

NOTES:  
 ADDITIONAL "a" BARS SHALL BE FURNISHED AND PLACED BY THE CONTRACTOR. THE ADDITIONAL BARS ARE NOT INCLUDED IN THE LISTED QUANTITIES, BUT WILL BE PAID FOR AS REINFORCEMENT BARS (EPOXY COATED).  
 1 ADDITIONAL BAR REQUIRED FOR EACH 15° SKEW OR FRACTION THEREOF.

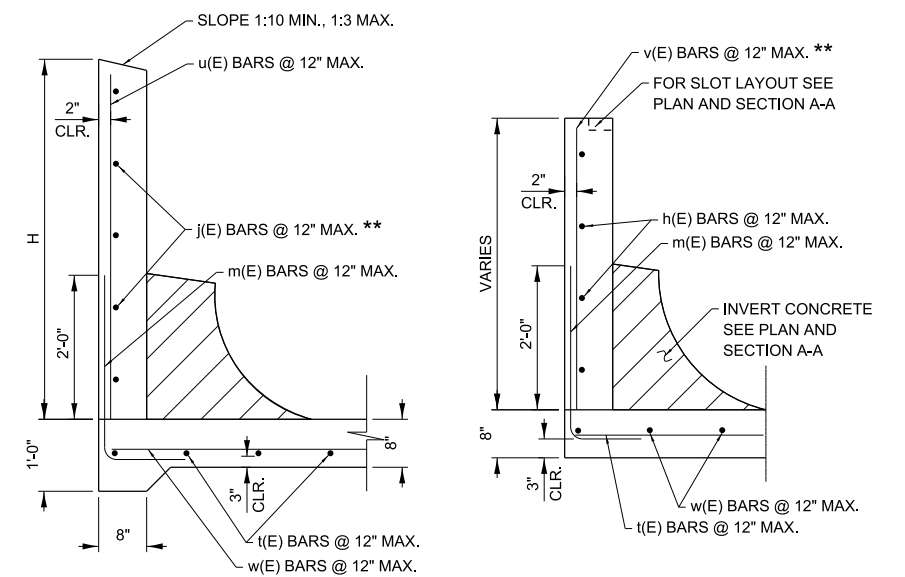

SECTION B-B

SECTION C-C

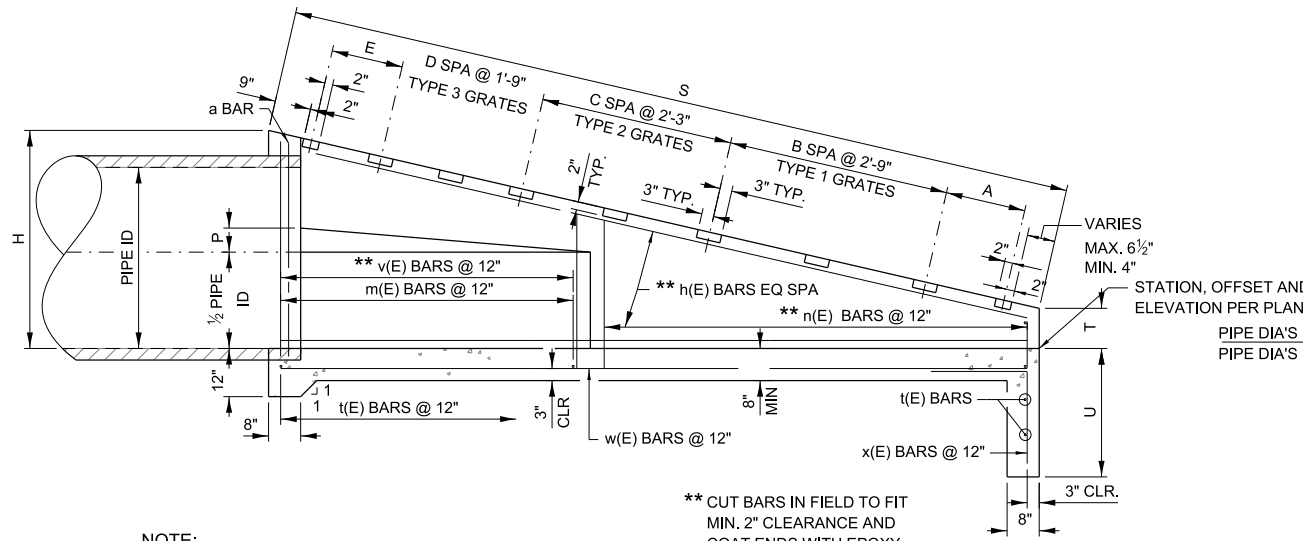

SECTION A-A

NOTE:  
 "v" AND "m" BARS ARE TO BEGIN AT THE PIPE END OF THE SLOPED WINGWALLS.

\*\* CUT BARS IN FIELD TO FIT MIN. 2" CLEARANCE AND COAT ENDS WITH EPOXY.

PIPE DIA'S 18", 24" & 30"  
 PIPE DIA'S 36", 42", 48", 54" & 60"

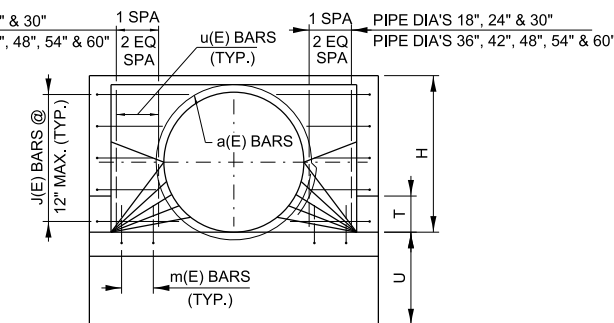

FRONT ELEVATION

- NOTES:
1. HEADWALL TYPE III SHALL BE CONSTRUCTED FLUSH WITH EXISTING OR PROPOSED SLOPE.
  2. CLASS SI CONCRETE SHALL BE USED THROUGHOUT.
  3. ALL REINFORCEMENT BARS SHOWN SHALL BE EPOXY COATED (E).
  4. BAR BENDING DETAILS ARE DIMENSIONED OUT TO OUT OF BARS.
  5. ALL EXPOSED EDGES SHALL HAVE A 3/8" - 45° CHAMFER. CHAMFER ON VERTICAL EDGES SHALL BE CONTINUED A MINIMUM OF ONE FOOT BELOW THE FINISHED GROUND LINE.
  6. COVER FROM THE FACE OF CONCRETE TO FACE OF REINFORCEMENT BAR SHALL BE 3" FOR SURFACES FORMED AGAINST EARTH AND 2" FOR ALL OTHER SURFACES UNLESS OTHERWISE SHOWN.
  7. CARE SHALL BE EXERCISED IN REMOVING ANY LENGTH OF EXISTING PIPE SO THE REMAINING PIPE IS UNDAMAGED AND FULLY FUNCTIONING.
  8. FOR DIMENSIONS AND QUANTITIES FOR ONE HEADWALL, SEE SHEET 2 IN THIS SERIES.
  9. FOR STEEL GRATING DETAILS, SEE SHEET 3 IN THIS SERIES.
  10. FOR ALTERNATE PRECAST CONCRETE DETAILS AND NOTES, SEE SHEET 4 IN THIS SERIES.
  11. ALL SLOPES ARE EXPRESSED AS UNITS OF VERTICAL DISPLACEMENT TO UNITS OF HORIZONTAL DISPLACEMENT (V:H).

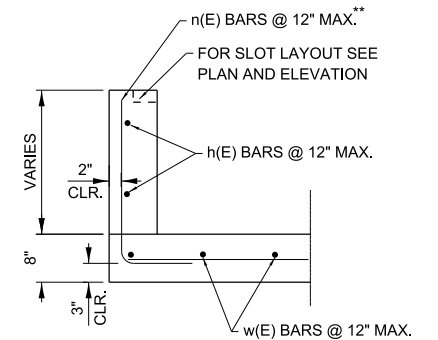

SECTION D-D

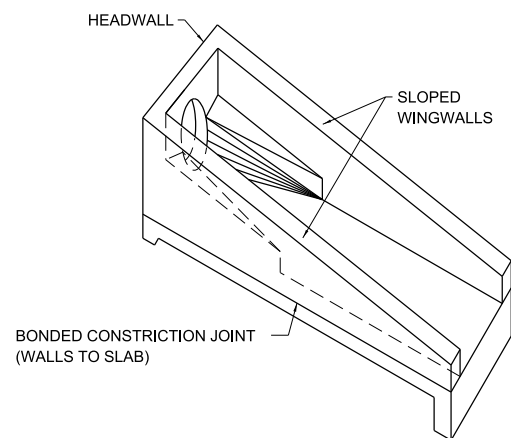

ISOMETRIC VIEW

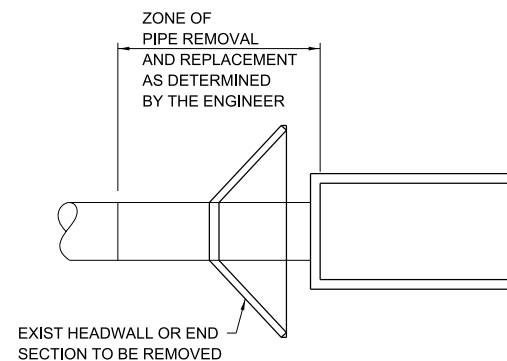

INSTALLATION DETAIL

APPROVED BY: *Paul Kovacs* CHIEF ENGINEERING OFFICER  
 DATE: 03/01/2022

REVISIONS	
DATE	DESCRIPTION
03-01-2022	REVISED BAR NO. 1 THICKNESS AND WEIGHT OF HEADWALL GRATES
03-01-2021	ADJUSTED LENGTH OF "i" BARS FOR THE 1:3 SLOPE HEADWALL
03-01-2019	MINOR EDIT

**Illinois Tollway**

**HEADWALL TYPE III**  
 18"-24"-30"-36"-42"-48"-54"-60"  
 FOR 1:3, 1:4, 1:6, AND 1:10 SLOPES

VERSION: 2022-03  
 STANDARD: B6-09  
 SHEET: 1 OF 4

**DIMENSIONS AND QUANTITIES IN ONE HEADWALL TYPE III 1:3 SLOPE**

PIPE DIA	DIMENSIONS											NO. OF SPACES			CONCRETE CLASS SI CU. YD.	REINF. BARS LB.
	H	L	M	P	S	T	U	V	W	A	E	B	C	D		
36"	3'-10"	11'-0"	3'-3"	4"	11'-7"	2"	2'-8"	6'-0"	7'-4"	2'-2"	1'-8"	0	2	1	3.8	347
42"	4'-5"	12'-9"	3'-10"	6"	13'-5"	2"	3'-2"	6'-6"	7'-10"	2'-2"	1'-8"	0	2	2	4.6	444
48"	5'-0"	14'-6"	4'-4"	6"	15'-3"	2"	3'-2"	7'-0"	8'-4"	1'-8"	1'-8"	0	0	6	5.5	502
54"	5'-6"	16'-0"	4'-10"	8"	16'-10"	2"	3'-6"	7'-6"	8'-10"	2'-2"	1'-8"	0	2	4	6.4	613
60"	6'-0"	17'-6"	5'-3"	8"	18'-5"	2"	3'-6"	8'-0"	9'-4"	2'-8"	1'-8"	2	0	4	7.3	668

**DIMENSIONS AND QUANTITIES IN ONE HEADWALL TYPE III 1:4 SLOPE**

PIPE DIA	DIMENSIONS											NO. OF SPACES			CONCRETE CLASS SI CU. YD.	REINF. BARS LB.
	H	L	M	P	S	T	U	V	W	A	E	B	C	D		
36"	3'-10"	14'-8"	4'-5"	4"	15'-2"	2"	2'-8"	6'-0"	7'-4"	2'-8"	2'-8"	3	0	0	4.7	415
42"	4'-5"	17'-0"	5'-1"	6"	17'-6"	2"	3'-2"	6'-6"	7'-10"	2'-8"	2'-2"	0	5	0	5.8	546
48"	5'-0"	19'-4"	5'-10"	6"	19'-11"	2"	3'-2"	7'-0"	8'-4"	2'-8"	2'-2"	0	6	0	6.9	625
54"	5'-6"	21'-4"	6'-5"	8"	22'-0"	2"	3'-6"	7'-6"	8'-10"	2'-8"	2'-2"	0	7	0	8.0	788
60"	6'-0"	23'-4"	7'-0"	8"	24'-1"	2"	3'-6"	8'-0"	9'-4"	1'-8"	1'-8"	0	0	11	9.1	837

**DIMENSIONS AND QUANTITIES IN ONE HEADWALL TYPE III 1:6 SLOPE**

PIPE DIA	DIMENSIONS											NO. OF SPACES			CONCRETE CLASS SI CU. YD.	REINF. BARS LB.
	H	L	M	P	S	T	U	V	W	A	E	B	C	D		
36"	3'-10"	22'-0"	6'-8"	4"	22'-4"	2"	2'-8"	6'-0"	7'-4"	1'-8"	1'-8"	0	0	10	7.5	573
42"	4'-5"	25'-6"	7'-8"	6"	25'-10"	2"	3'-2"	6'-6"	7'-10"	1'-8"	1'-8"	0	0	12	9.5	746
48"	5'-0"	29'-0"	8'-9"	6"	29'-5"	2"	3'-2"	7'-0"	8'-4"	1'-8"	1'-8"	0	0	14	11.7	863
54"	5'-6"	32'-0"	9'-8"	8"	32'-5"	2"	3'-6"	7'-6"	8'-10"	2'-2"	1'-8"	0	5	9	13.9	1047
60"	6'-0"	35'-0"	10'-6"	8"	35'-6"	2"	3'-6"	8'-0"	9'-4"	2'-2"	1'-8"	0	1	16	16.3	1177

**DIMENSIONS AND QUANTITIES IN ONE HEADWALL TYPE III 1:10 SLOPE**

PIPE DIA	DIMENSIONS											NO. OF SPACES			CONCRETE CLASS SI CU. YD.	REINF. BARS LB.
	H	L	M	P	S	T	U	V	W	A	E	B	C	D		
18"	2'-3"	20'-10"	6'-3"	2"	20'-11 1/2"	2"	2'-8"	3'-0"	4'-4"	2'-8"	2'-2"	2	4	0	4.1	368
24"	2'-9"	25'-10"	7'-9"	3"	25'-11 1/2"	2"	2'-8"	4'-0"	5'-4"	1'-8"	1'-8"	0	0	12	6.1	490
30"	3'-4"	31'-8"	9'-6"	4"	31'-10"	2"	2'-8"	5'-0"	6'-4"	2'-8"	2'-2"	6	4	0	8.8	705
36"	3'-10"	36'-8"	11'-0"	4"	36'-10 1/2"	2"	2'-8"	6'-0"	7'-4"	2'-8"	2'-2"	7	5	0	11.9	944
42"	4'-5"	42'-6"	12'-9"	6"	42'-8 1/2"	2"	3'-2"	6'-6"	7'-10"	2'-8"	2'-8"	13	0	0	15.2	1178
48"	5'-0"	48'-4"	14'-6"	6"	48'-7 1/2"	2"	3'-2"	7'-0"	8'-4"	2'-2"	2'-2"	0	19	0	18.8	1457
54"	5'-6"	53'-4"	16'-0"	8"	53'-7 1/2"	2"	3'-6"	7'-6"	8'-10"	2'-8"	2'-8"	17	0	0	22.4	1687
60"	6'-0"	58'-4"	17'-6"	8"	58'-7 1/2"	2"	3'-6"	8'-0"	9'-4"	2'-8"	2'-2"	19	0	0	26.2	1964

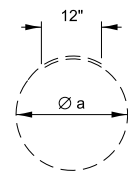

TYPE 1

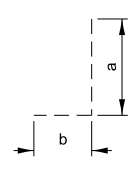

TYPE 2

**REINFORCEMENT BARS SCHEDULE FOR ONE HEADWALL**

**TYPE III 1:10 SLOPE**

PIPE DIA	NO 4 REINFORCEMENT BARS					
	MARK(E)	TYPE	NO REQ'D	LENGTH	a	b
18"	a18	1	1	8'-7"	2'-5"	-
	n18	2	32	2'-7"	1'-10"	9"
	m18	2	18	3'-2"	2'-5"	9"
	j18	2	6	4'-0"	2'-0"	2'-0"
	h18	STR.	6	20'-8"	-	-
	x18	2	5	4'-3"	2'-3"	2'-0"
	t18	STR.	23	4'-0"	-	-
	u18	STR.	4	2'-1"	-	-
	v18	STR.	14	2'-1"	-	-
	w18	STR.	5	20'-6"	-	-
24"	a24	1	1	10'-5"	3'-0"	-
	n24	2	38	2'-11"	2'-2"	9"
	m24	2	20	3'-2"	2'-5"	9"
	j24	2	6	4'-0"	2'-0"	2'-0"
	h24	STR.	6	25'-8"	-	-
	x24	2	6	4'-3"	2'-3"	2'-0"
	t24	STR.	28	5'-0"	-	-
	u24	STR.	4	2'-7"	-	-
	v24	STR.	16	2'-7"	-	-
	w24	STR.	6	25'-6"	-	-
30"	a30	1	1	12'-3"	3'-7"	-
	n30	2	46	3'-4"	2'-7"	9"
	m30	2	24	3'-2"	2'-5"	9"
	j30	2	8	4'-0"	2'-0"	2'-0"
	h30	STR.	8	31'-6"	-	-
	x30	2	7	4'-3"	2'-3"	2'-0"
	t30	STR.	34	6'-0"	-	-
	u30	STR.	4	3'-2"	-	-
	v30	STR.	20	3'-2"	-	-
	w30	STR.	7	31'-4"	-	-
36"	a36	1	1	13'-10"	4'-1"	-
	n36	2	52	3'-8"	2'-11"	9"
	m36	2	30	3'-2"	2'-5"	9"
	j36	2	10	4'-0"	2'-0"	2'-0"
	h36	STR.	10	36'-6"	-	-
	x36	2	8	4'-3"	2'-3"	2'-0"
	t36	STR.	39	7'-0"	-	-
	u36	STR.	6	3'-8"	-	-
	v36	STR.	24	3'-8"	-	-
	w36	STR.	8	36'-4"	-	-
42"	a42	1	1	15'-11"	4'-9"	-
	n42	2	62	3'-8"	2'-11"	9"
	m42	2	34	3'-2"	2'-5"	9"
	j42	2	10	4'-0"	2'-0"	2'-0"
	h42	STR.	20	22'-2"	-	-
	x42	2	9	4'-7"	2'-7"	2'-0"
	t42	STR.	46	7'-6"	-	-
	u42	STR.	6	4'-3"	-	-
	v42	STR.	28	4'-3"	-	-
	w42	STR.	18	22'-1"	-	-
48"	a48	1	1	17'-9"	5'-4"	-
	n48	2	70	4'-6"	3'-9"	9"
	m48	2	36	3'-2"	2'-5"	9"
	j48	2	12	4'-0"	2'-0"	2'-0"
	h48	STR.	24	25'-2"	-	-
	x48	2	9	4'-7"	2'-7"	2'-0"
	t48	STR.	52	8'-0"	-	-
	u48	STR.	6	4'-10"	-	-
	v48	STR.	30	4'-10"	-	-
	w48	STR.	18	25'-0"	-	-
54"	a54	1	1	19'-7"	5'-11"	-
	n54	2	76	4'-10"	4'-1"	9"
	m54	2	40	3'-2"	2'-5"	9"
	j54	2	12	4'-0"	2'-0"	2'-0"
	h54	STR.	24	27'-8"	-	-
	x54	2	10	5'-1"	3'-1"	2'-0"
	t54	STR.	57	8'-6"	-	-
	u54	STR.	6	5'-4"	-	-
	v54	STR.	34	5'-4"	-	-
	w54	STR.	20	27'-6"	-	-
60"	a60	1	1	21'-2"	6'-5"	-
	n60	2	82	5'-3"	4'-6"	9"
	m60	2	42	3'-2"	2'-5"	9"
	j60	2	14	4'-0"	2'-0"	2'-0"
	h60	STR.	28	30'-2"	-	-
	x60	2	10	5'-1"	3'-1"	2'-0"
	t60	STR.	62	9'-0"	-	-
	u60	STR.	6	5'-10"	-	-
	v60	STR.	36	5'-10"	-	-
	w60	STR.	20	30'-0"	-	-

**REINFORCEMENT BARS SCHEDULE FOR ONE HEADWALL**

**TYPE III 1:6 SLOPE**

PIPE DIA	NO 4 REINFORCEMENT BARS					
	MARK(E)	TYPE	NO REQ'D	LENGTH	a	b
36"	a36	1	1	13'-10"	4'-1"	-
	n36	2	32	3'-8"	2'-11"	9"
	m36	2	20	3'-2"	2'-5"	9"
	j36	2	8	4'-0"	2'-0"	2'-0"
	h36	STR.	8	22'-0"	-	-
	x36	2	8	4'-3"	2'-0"	2'-0"
	t36	STR.	25	7'-0"	-	-
	u36	STR.	6	3'-7"	-	-
	v36	STR.	14	3'-7"	-	-
	w36	STR.	8	21'-8"	-	-
42"	a42	1	1	15'-11"	4'-9"	-
	n42	2	38	4'-2"	3'-5"	9"
	m42	2	22	3'-2"	2'-5"	9"
	j42	2	10	4'-0"	2'-0"	2'-0"
	h42	STR.	10	25'-6"	-	-
	x42	2	9	4'-7"	2'-7"	2'-0"
	t42	STR.	29	7'-6"	-	-
	u42	STR.	6	4'-2"	-	-
	v42	STR.	16	4'-2"	-	-
	w42	STR.	9	25'-2"	-	-
48"	a48	1	1	17'-9"	5'-4"	-
	n48	2	42	4'-6"	3'-9"	9"
	m48	2	24	3'-2"	2'-5"	9"
	j48	2	10	4'-0"	2'-0"	2'-0"
	h48	STR.	10	29'-1"	-	-
	x48	2	9	4'-7"	2'-7"	2'-0"
	t48	STR.	33	8'-0"	-	-
	u48	STR.	6	4'-9"	-	-
	v48	STR.	18	4'-9"	-	-
	w48	STR.	9	28'-8"	-	-
54"	a54	1	1	19'-7"	5'-11"	-
	n54	2	46	4'-10"	4'-1"	9"
	m54	2	26	3'-2"	2'-5"	9"
	j54	2	12	4'-0"	2'-0"	2'-0"
	h54	STR.	12	32'-1"	-	-
	x54	2	10	5'-1"	3'-1"	2'-0"
	t54	STR.	36	8'-6"	-	-
	u54	STR.	6	5'-3"	-	-
	v54	STR.	20	5'-3"	-	-
	w54	STR.	10	31'-8"	-	-
60"	a60	1	1	21'-2"	6'-5"	-
	n60	2	50	5'-3"	4'-6"	9"
	m60	2	28	3'-2"	2'-5"	9"
	j60	2	12	4'-0"	2'-0"	2'-0"
	h60	STR.	12	35'-2"	-	-
	x60	2	10	5'-1"	3'-1"	2'-0"
	t60	STR.	40	9'-0"	-	-
	u60	STR.	6	5'-9"	-	-
	v60	STR.	22	5'-9"	-	-
	w60	STR.	10	34'-8"	-	-

**REINFORCEMENT BARS SCHEDULE FOR ONE HEADWALL**

**TYPE III 1:4 SLOPE**

PIPE DIA	NO 4 REINFORCEMENT BARS					
	MARK(E)	TYPE	NO REQ'D	LENGTH	a	b
36"	a36	1	1	13'-10"	4'-1"	-
	n36	2	22	3'-8"	2'-11"	9"
	m36	2	16	3'-2"	2'-5"	9"
	j36	2	8	4'-0"	2'-0"	2'-0"
	h36	STR.	8	14'-10"	-	-
	x36	2	8	4'-3"	2'-3"	2'-0"
	t36	STR.	17	7'-0"	-	-
	u36	STR.	6	3'-7"	-	-
	v36	STR.	10	3'-7"	-	-
	w36	STR.	8	14'-4"	-	-
42"	a42	1	1	15'-11"	4'-9"	-
	n42	2	26	4'-2"	3'-5"	9"
	m42	2	18	3'-2"	2'-5"	9"
	j42	2	10	4'-0"	2'-0"	2'-0"
	h42	STR.	10	17'-2"	-	-
	x42	2	9	4'-7"	2'-7"	2'-0"
	t42	STR.	21	7'-6"	-	-
	u42	STR.	6	4'-2"	-	-
	v42	STR.	12	4'-2"	-	-
	w42	STR.	9	16'-8"	-	-
48"	a48	1	1	17'-9"	5'-4"	-
	n48	2	28	4'-6"	3'-9"	9"
	m48	2	20	3'-2"	2'-5"	9"
	j48	2	10	4'-0"	2'-0"	2'-0"
	h48	STR.	10	19'-		

**GRATE DIMENSIONS AND QUANTITIES IN ONE  
HEADWALL TYPE III END ENTRANCE 1:3 SLOPE**

INSIDE PIPE DIAMETER	GRATES		BARS FOR ONE GRATE				HEADWALL GRATES (POUND)	
	NUMBER REQUIRED	TYPE REQ'D	BAR NO 1		BAR NO 2		EACH GRATE	TOTAL
			BARS REQ'D	LENGTH	BARS REQ'D	LENGTH		
36"	0	1	2	6'-7"	11	2'-4"	133	601
	3	2	2	6'-7"	11	1'-10"	124	
	2	3	2	6'-7"	11	1'-4"	115	
42"	0	1	2	7'-1"	12	2'-4"	144	772
	3	2	2	7'-1"	12	1'-10"	134	
	3	3	2	7'-1"	12	1'-4"	124	
48"	0	1	2	7'-7"	13	2'-4"	155	1062
	0	2	2	7'-7"	13	1'-10"	144	
	8	3	2	7'-7"	13	1'-4"	133	
54"	0	1	2	8'-1"	14	2'-4"	166	1170
	3	2	2	8'-1"	14	1'-10"	154	
	5	3	2	8'-1"	14	1'-4"	142	
60"	3	1	2	8'-7"	15	2'-4"	176	1283
	0	2	2	8'-7"	15	1'-10"	164	
	5	3	2	8'-7"	15	1'-4"	151	

**GRATE DIMENSIONS AND QUANTITIES IN ONE  
HEADWALL TYPE III END ENTRANCE 1:4 SLOPE**

INSIDE PIPE DIAMETER	GRATES		BARS FOR ONE GRATE				HEADWALL GRATES (POUND)	
	NUMBER REQUIRED	TYPE REQ'D	BAR NO 1		BAR NO 2		EACH GRATE	TOTAL
			BARS REQ'D	LENGTH	BARS REQ'D	LENGTH		
36"	5	1	2	6'-7"	11	2'-4"	133	666
	0	2	2	6'-7"	11	1'-10"	124	
	0	3	2	6'-7"	11	1'-4"	115	
42"	1	1	2	7'-1"	12	2'-4"	144	947
	6	2	2	7'-1"	12	1'-10"	134	
	0	3	2	7'-1"	12	1'-4"	124	
48"	1	1	2	7'-7"	13	2'-4"	155	1161
	7	2	2	7'-7"	13	1'-10"	144	
	0	3	2	7'-7"	13	1'-4"	133	
54"	1	1	2	8'-1"	14	2'-4"	166	1395
	8	2	2	8'-1"	14	1'-10"	154	
	0	3	2	8'-1"	14	1'-4"	142	
60"	0	1	2	8'-7"	15	2'-4"	176	1961
	0	2	2	8'-7"	15	1'-10"	164	
	13	3	2	8'-7"	15	1'-4"	151	

**GRATE DIMENSIONS AND QUANTITIES IN ONE HEADWALL TYPE III END  
ENTRANCE 1:10 SLOPE**

INSIDE PIPE DIAMETER	GRATES		BARS FOR ONE GRATE				HEADWALL GRATES (POUND)	
	NUMBER REQUIRED	TYPE REQ'D	BAR NO 1		BAR NO 2		EACH GRATE	TOTAL
			BARS REQ'D	LENGTH	BARS REQ'D	LENGTH		
18"	3	1	2	3'-7"	5	2'-4"	69	528
	5	2	2	3'-7"	5	1'-10"	64	
	0	3	2	3'-7"	5	1'-4"	60	
24"	0	1	2	4'-7"	7	2'-4"	90	1096
	0	2	2	4'-7"	7	1'-10"	84	
	14	3	2	4'-7"	7	1'-4"	78	
30"	7	1	2	5'-7"	9	2'-4"	112	1302
	5	2	2	5'-7"	9	1'-10"	104	
	0	3	2	5'-7"	9	1'-4"	96	
36"	8	1	2	6'-7"	11	2'-4"	133	1810
	6	2	2	6'-7"	11	1'-10"	124	
	0	3	2	6'-7"	11	1'-4"	115	
42"	15	1	2	7'-1"	12	2'-4"	144	2161
	0	2	2	7'-1"	12	1'-10"	134	
	0	3	2	7'-1"	12	1'-4"	124	
48"	0	1	2	7'-7"	13	2'-4"	155	3019
	21	2	2	7'-7"	13	1'-10"	144	
	0	3	2	7'-7"	13	1'-4"	133	
54"	19	1	2	8'-1"	14	2'-4"	166	3146
	0	2	2	8'-1"	14	1'-10"	154	
	0	3	2	8'-1"	14	1'-4"	142	
60"	20	1	2	8'-7"	15	2'-4"	176	3691
	1	2	2	8'-7"	15	1'-10"	164	
	0	3	2	8'-7"	15	1'-4"	151	

**GRATE DIMENSIONS AND QUANTITIES IN  
ONE HEADWALL TYPE III END ENTRANCE 1:6 SLOPE**

INSIDE PIPE DIAMETER	GRATES		BARS FOR ONE GRATE				HEADWALL GRATES (POUND)	
	NUMBER REQUIRED	TYPE REQ'D	BAR NO 1		BAR NO 2		EACH GRATE	TOTAL
			BARS REQ'D	LENGTH	BARS REQ'D	LENGTH		
36"	0	1	2	6'-7"	11	2'-4"	133	1375
	0	2	2	6'-7"	11	1'-10"	124	
	12	3	2	6'-7"	11	1'-4"	115	
42"	0	1	2	7'-1"	12	2'-4"	144	1731
	0	2	2	7'-1"	12	1'-10"	134	
	14	3	2	7'-1"	12	1'-4"	124	
48"	0	1	2	7'-7"	13	2'-4"	155	2123
	0	2	2	7'-7"	13	1'-10"	144	
	16	3	2	7'-7"	13	1'-4"	133	
54"	0	1	2	8'-1"	14	2'-4"	166	2340
	6	2	2	8'-1"	14	1'-10"	154	
	10	3	2	8'-1"	14	1'-4"	142	
60"	0	1	2	8'-7"	15	2'-4"	176	2892
	2	2	2	8'-7"	15	1'-10"	164	
	17	3	2	8'-7"	15	1'-4"	151	

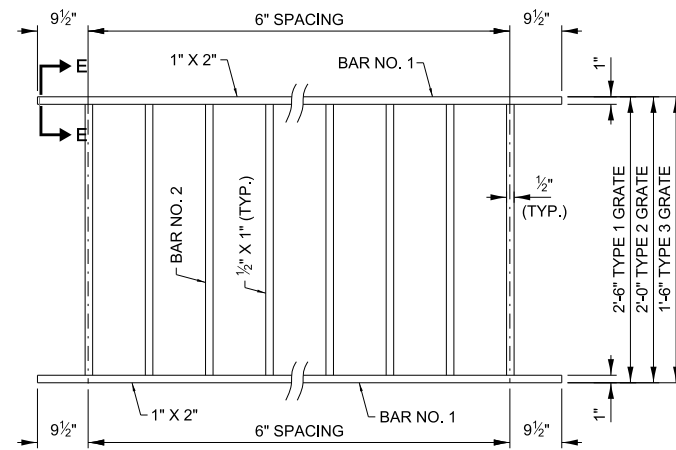

**TYPICAL GRATE**

**NOTES:**

- ALL STRUCTURAL STEEL SHALL BE AASHTO M270, GRADE 36 OR 50.
- GALVANIZING SHALL BE IN ACCORDANCE WITH THE STANDARD SPECIFICATIONS.
- FOR PLACEMENT OF GRATES, SEE SHEET 1 IN THIS SERIES.
- ALL TABLE DIMENSIONS AND QUANTITIES ARE FOR SINGLE HEADWALL, TYPE III.
- ALL SLOPES ARE EXPRESSED AS UNITS OF VERTICAL DISPLACEMENT TO UNITS OF HORIZONTAL DISPLACEMENT (V:H).
- GRATING IS DESIGNED FOR A TRANSVERSING LOAD OF 1,800 POUNDS AT YIELD.

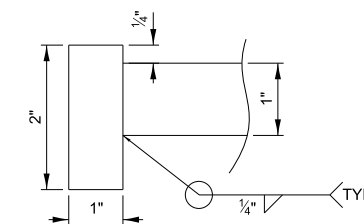

**SECTION E-E**



**HEADWALL TYPE III  
18"-24"-30"-36"-42"-48"-54"-60"  
FOR 1:3, 1:4, 1:6, AND  
1:10 SLOPES**

APPROVED BY:

DATE:

*Paul Kovacs*  
CHIEF ENGINEERING OFFICER

03/01/2022

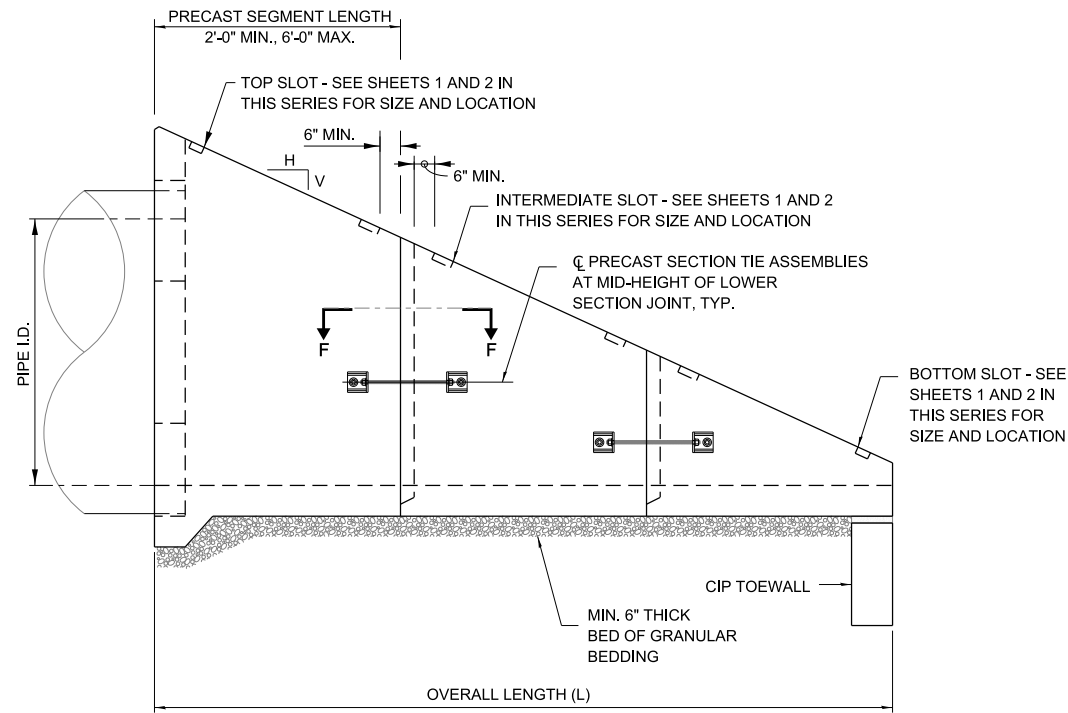

ELEVATION

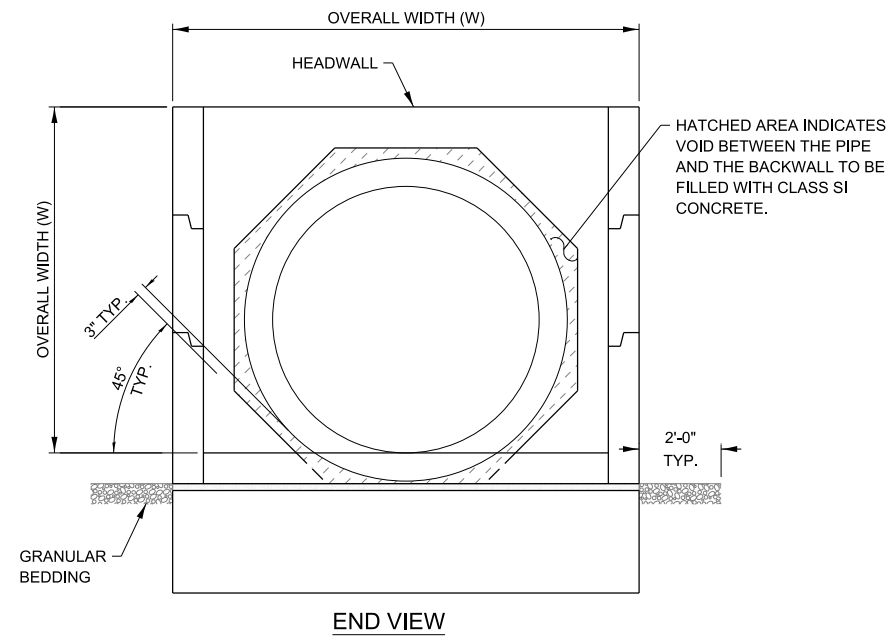

GENERAL NOTES:

1. THE NUMBER OF SEGMENTS SHOWN IN ELEVATION IS FOR EXAMPLE ONLY. THE LENGTH AND NUMBER OF PRECAST SECTIONS REQUIRED TO CONSTRUCT THE END SECTION SHALL BE DETERMINED BY THE CONTRACTOR.
2. CONTRACTOR SHALL RETAIN THE SERVICES OF AN ILLINOIS LICENSED STRUCTURAL ENGINEER FOR PROPORTION, DESIGN AND DETAIL PRECAST SECTIONS FOR INSTALLATION AND FOR SERVICE. SEE CAST-IN-PLACE DIMENSIONS AND REINFORCING DETAILS FOR MINIMUM REQUIREMENTS. INCREASE MEMBER SIZES AND REINFORCING AS NECESSARY TO SATISFY HANDLING AND INSTALLATION STRESSES IN PRECAST SECTIONS.
3. CLASS "SI" CONCRETE SHALL BE USED THROUGHOUT.
4. REINFORCEMENT BARS (GRADE 60) SHALL BE EPOXY COATED. SEE CAST-IN-PLACE DETAILS FOR BENDING DIAGRAMS. SEE NOTES ON SHEET 1 IN THIS SERIES FOR REINFORCING COVER REQUIREMENTS.
5. ALL EXPOSED EDGES SHALL BE CHAMFERED. SEE NOTES ON SHEET 1 IN THIS SERIES.
6. SEE ROADWAY PLANS FOR SLOPE (V:H) AND PIPE INSIDE DIAMETER.
7. HOLES IN THE WALLS FOR THE PRECAST TIE ASSEMBLY MAY BE DRILLED USING CORE BITS IN LIEU OF FORMED HOLES. AVOID DAMAGE TO REINFORCING FROM DRILLING HOLES.
8. FOR STEEL GRATING DETAILS, SEE SHEET 3 IN THIS SERIES.
9. ALL SLOPE RATIOS ARE EXPRESSED AS UNITS OF VERTICAL DISPLACEMENT TO UNITS OF HORIZONTAL DISPLACEMENT (V:H).
10. TIE ASSEMBLIES, CONSISTING OF ANCHOR RODS, TIE PLATES, RESTRAINT ANGLES, RESTRAINT RODS AND ALL NUTS AND WASHERS SHALL CONFORM WITH AASHTO M270 GR36, OR GR50 AND SHALL BE HOT DIPPED GALVANIZED IN ACCORDANCE WITH AASHTO M 111 AFTER FABRICATION.

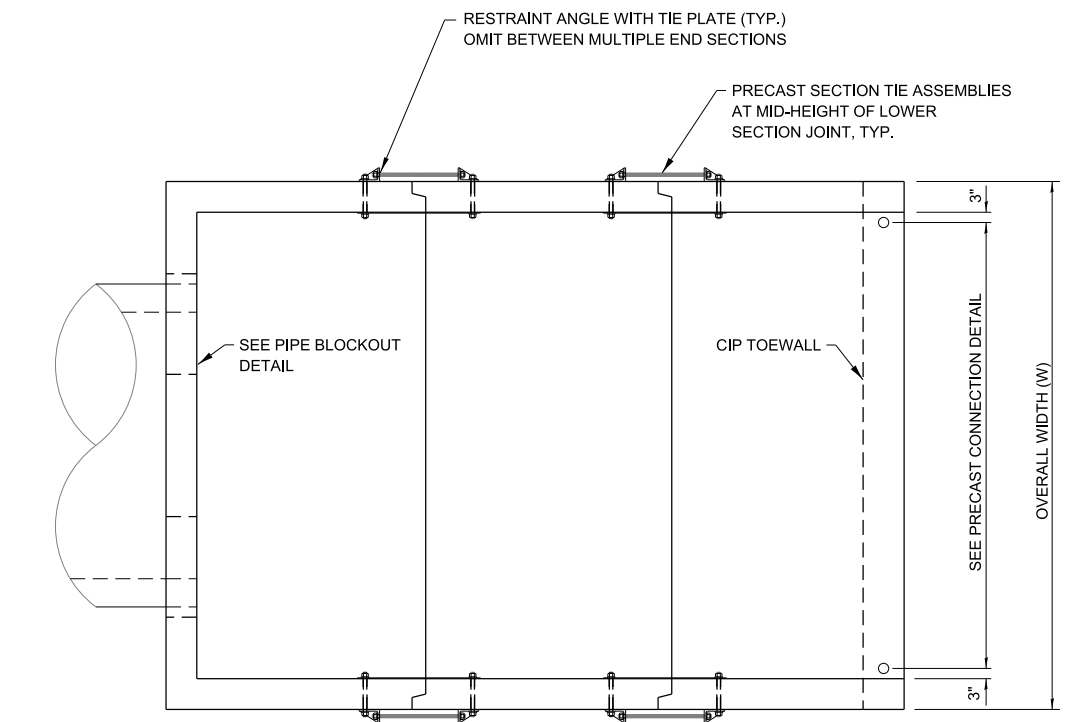

PLAN

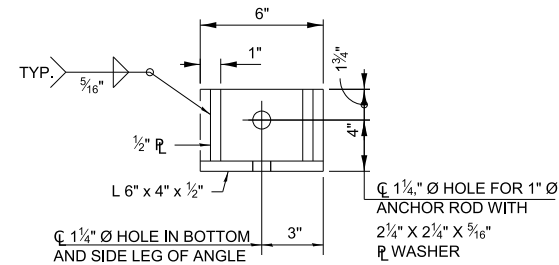

RESTRAINT ANGLE DETAIL

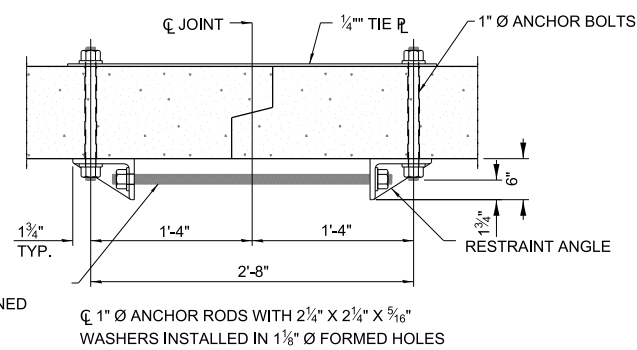
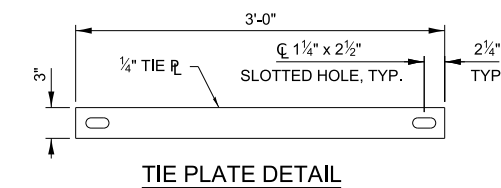

HEADWALL TYPE III ALTERNATE PRECAST CONCRETE DETAILS

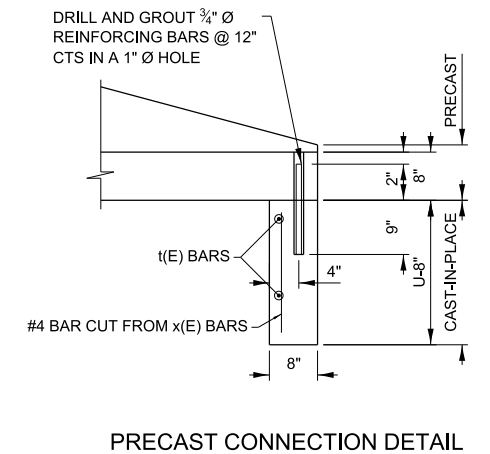

APPROVED BY: *Paul Kovacs* CHIEF ENGINEERING OFFICER  
DATE: 03/01/2022

**Illinois Tollway**

HEADWALL TYPE III  
18"-24"-30"-36"-42"-48"-54"-60"  
FOR 1:3, 1:4, 1:6, AND 1:10 SLOPES

VERSION: 2022-03 STANDARD: B6-09 SHEET: 4 OF 4

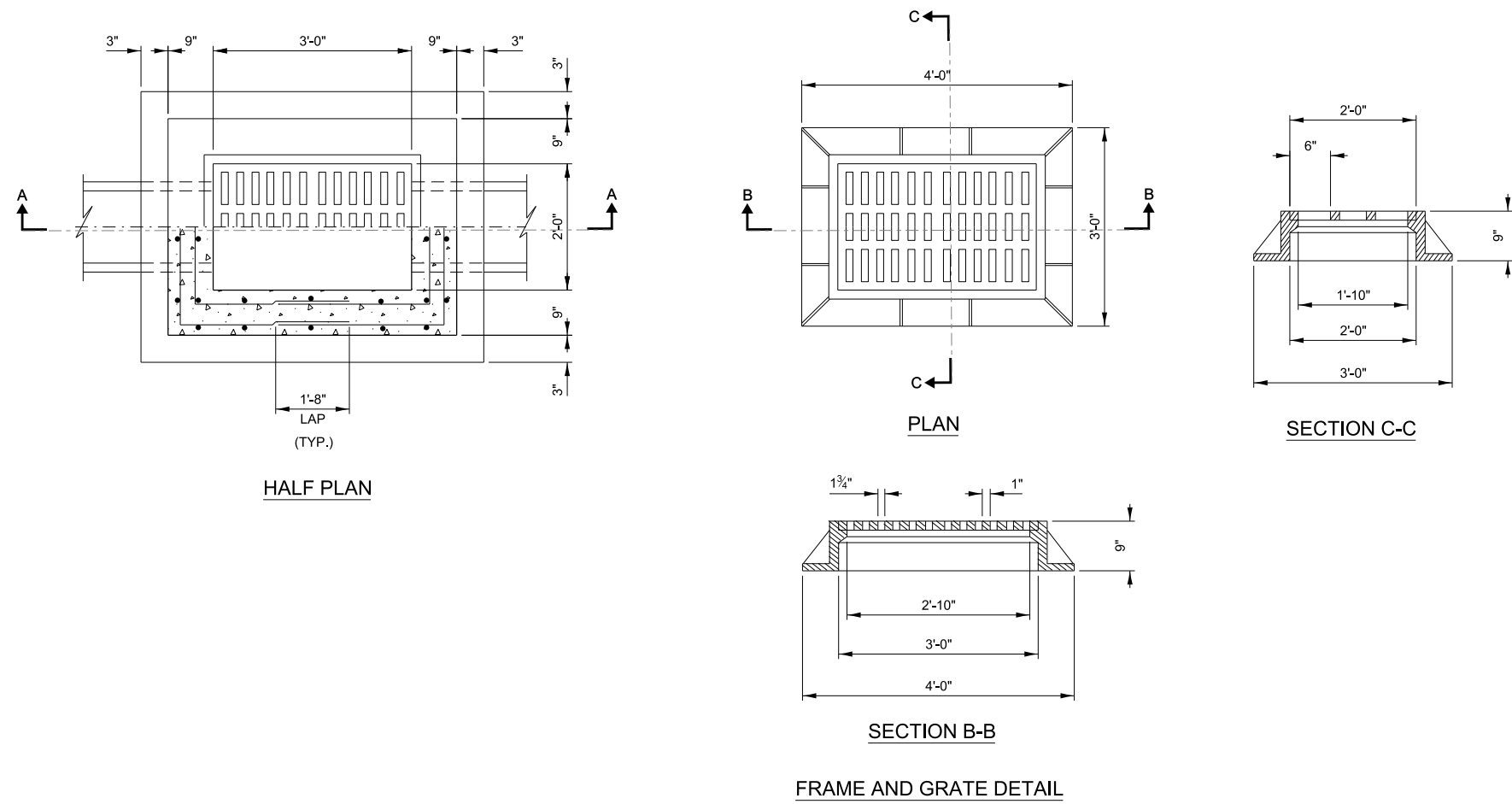

HALF PLAN

PLAN

SECTION C-C

SECTION B-B

FRAME AND GRATE DETAIL

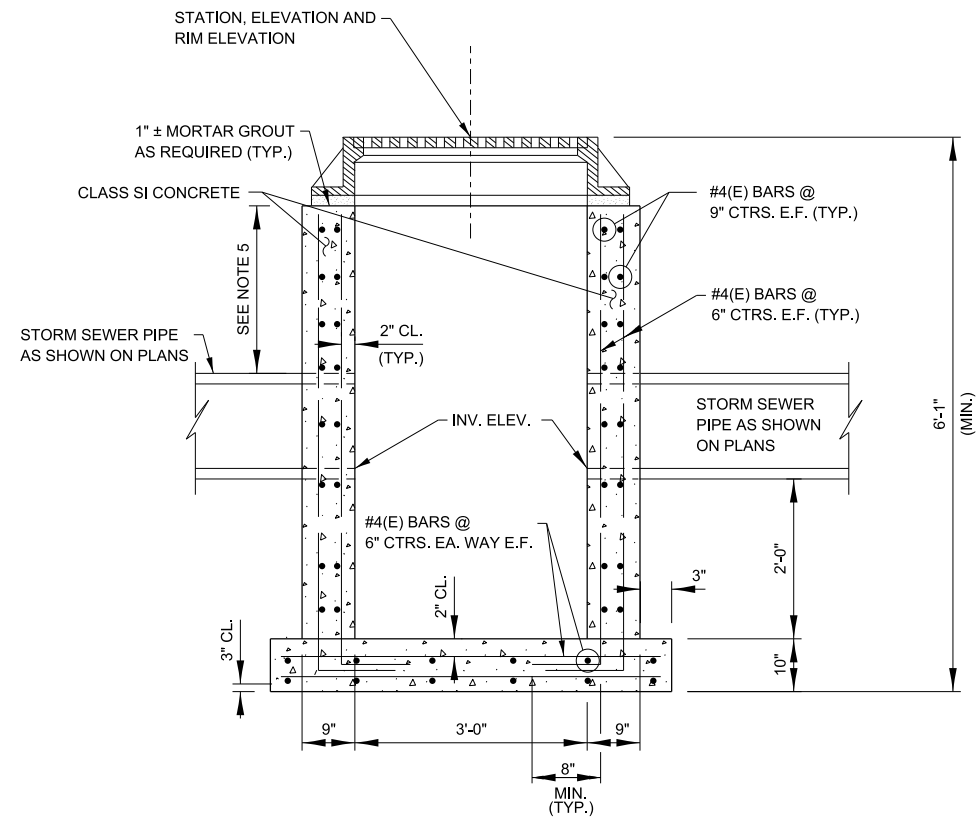

SECTION A-A

CATCH BASIN TYPE B

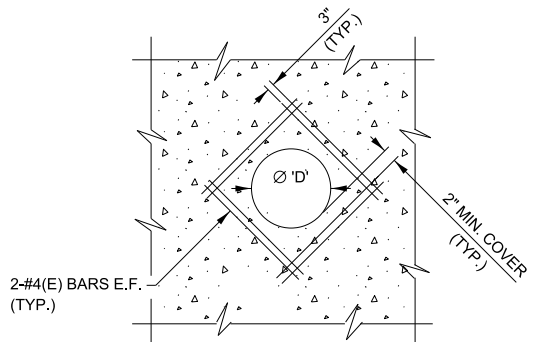

TYPICAL REINFORCEMENT AROUND STORM SEWER PIPE

NOTES:

- FOR MATERIALS AND CONSTRUCTION REQUIREMENTS OF THE CATCH BASIN, REFER TO THE STANDARD SPECIFICATIONS.
- FRAME AND GRATE FOR CATCH BASIN TYPE B SHALL BE NEENAH FOUNDRY COMPANY TYPE R-3455C, EAST JORDAN IRON WORKS V5360-1 OR APPROVED EQUAL.
- REINFORCEMENT BARS DESIGNATED (E) SHALL BE EPOXY COATED.
- THE CONTRACTOR SHALL CLEARLY MARK EACH CATCH BASIN WITH "ILLINOIS TOLLWAY", CONTRACT NUMBER, STRUCTURE NUMBER, PRODUCER NAME AND DATE OF MANUFACTURE. THIS INFORMATION SHALL BE MARKED ON THE OUTSIDE FACE OF THE STRUCTURE IN A VISIBLE SURFACE AS DESIGNATED BY THE ENGINEER. THE MARKING SHALL BE PAINTED/STAMPED IN THE STRUCTURE WITH WATERPROOF PAINT/INK OR RECESSED IN THE STRUCTURE BY 1/2". THE LETTERS SHALL BE CAPITALS, NOT LESS THAN 2 IN. AND NOT MORE THAN 3 IN. IN HEIGHT.
- A MINIMUM OF 9" OF MONOLITHIC REINFORCED CONCRETE SHALL BE MAINTAINED ABOVE PIPE PENETRATION HOLES >15".

APPROVED BY: *Paul Kovacs*  
 CHIEF ENGINEERING OFFICER  
 DATE: 03/01/2022

REVISIONS	
DATE	DESCRIPTION
03-01-2022	ADDED NOTES FOR MARKINGS AND MINIMUM 9" ABOVE PIPE PENETRATION HOLES
03-01-2020	REVISED TYPICAL REINFORCEMENT AROUND PIPE
03-11-2015	SLOPE DRAIN CHANGE TO BASE SHEET

**CATCH BASIN, TYPE B**

VERSION: 2022-03      STANDARD: B7-05      SHEET: 1 OF 1

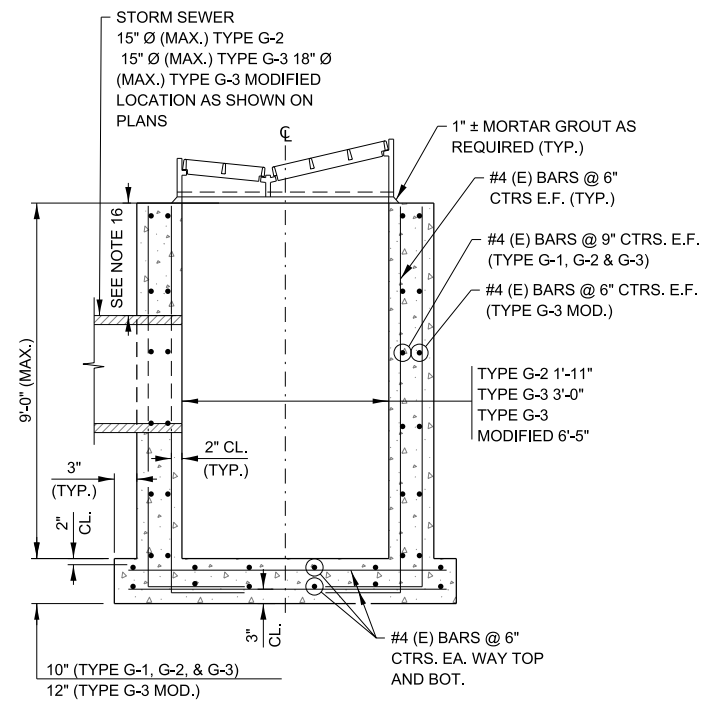

SECTION A-A

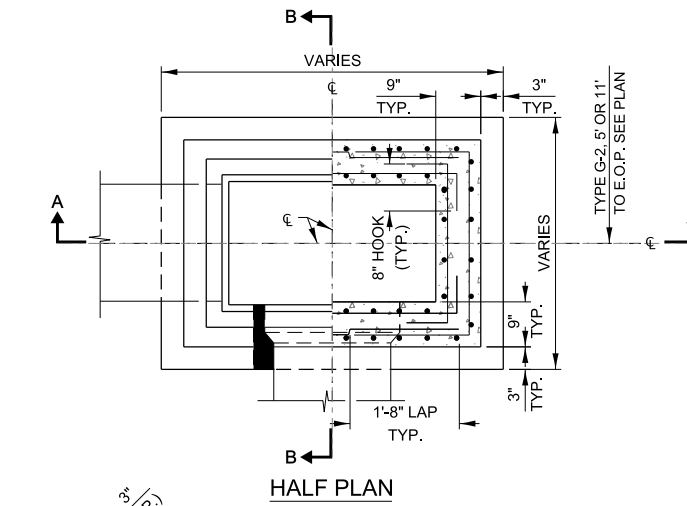

HALF PLAN

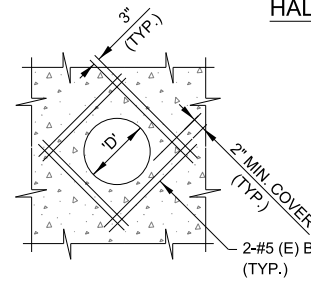

TYPICAL REINFORCEMENT AROUND STORM SEWER PIPE

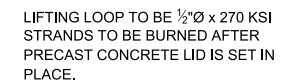

LIFTING LOOP DETAIL

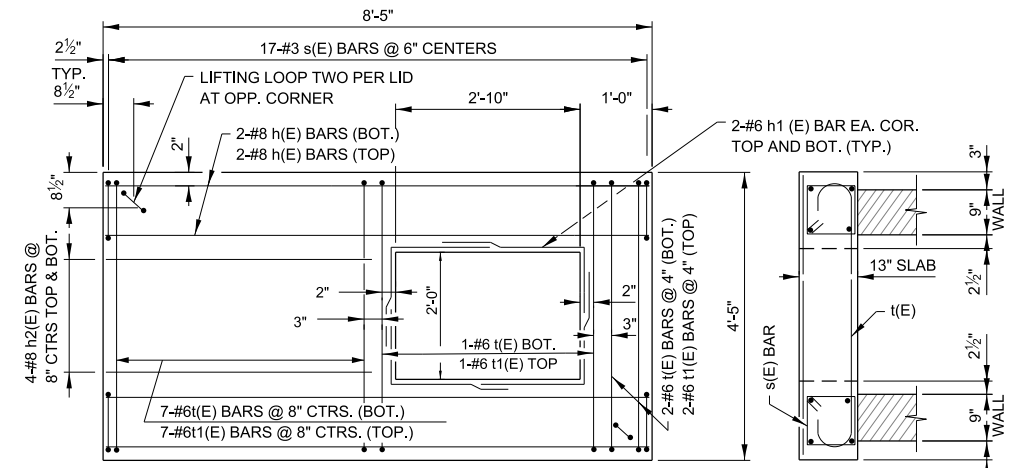

REINFORCED CONCRETE LID TYPE G-3 FRAME AND GRATE

CATCH BASIN, TYPE G-3, MODIFIED

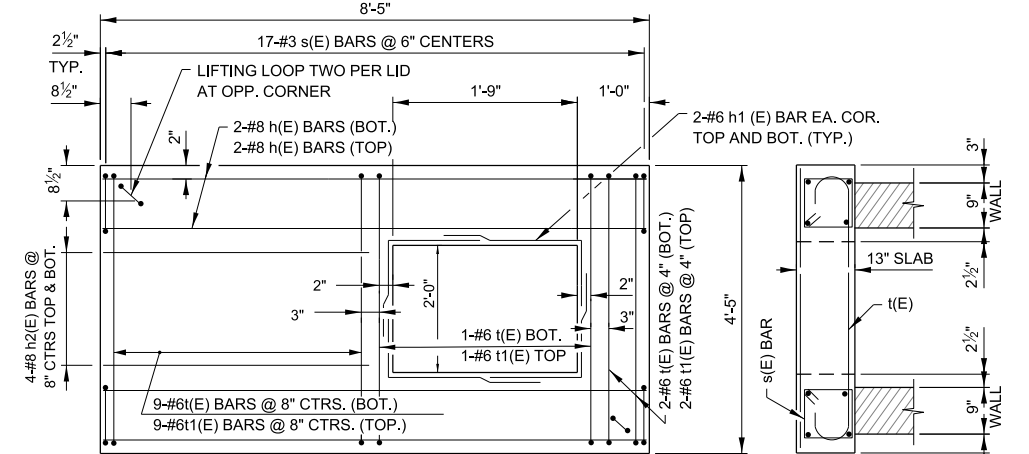

REINFORCED CONCRETE LID TYPE 20A FRAME AND GRATE

CATCH BASIN, TYPE G-3, MODIFIED

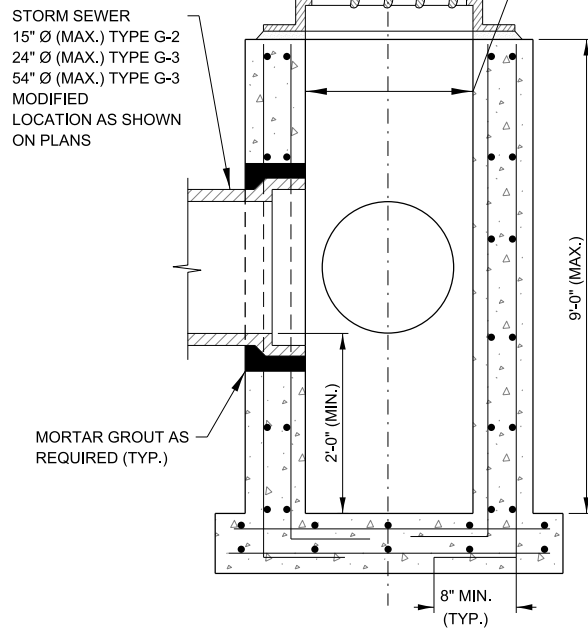
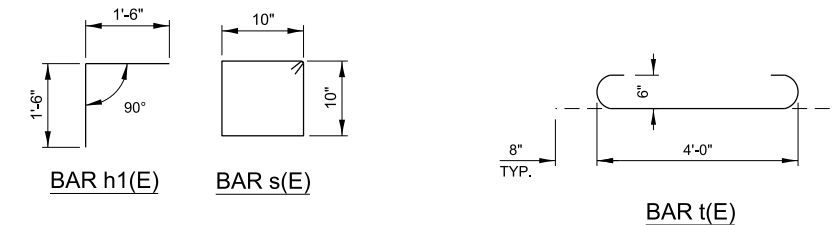

SECTION B-B CATCH BASIN TYPE "G" SERIES

NOTES:

1. PRECAST CONCRETE UNITS WILL BE ACCEPTABLE PROVIDED THEY MEET ALL THE REQUIREMENTS AS SHOWN ON THIS DRAWING. BASE EXTENSION OF 3" NOT REQUIRED FOR PRECAST UNITS. FABRICATION DRAWINGS SHOWING PIPE OPENINGS, REINFORCEMENT AND OTHER PERTINENT DIMENSIONS WILL BE REQUIRED FOR EACH UNIT, FOR APPROVAL BY THE ENGINEER PRIOR TO FABRICATION.
2. CATCH BASIN, TYPE G-2 SHALL BE USED ALONG RAMPS WHERE GUTTER TYPE G-2 IS PROVIDED.
3. CATCH BASIN, TYPE G-3 SHALL BE USED WHERE GUTTER TYPE G-3 IS PROVIDED.
4. CATCH BASIN, TYPE G-3 MODIFIED SHALL BE USED IN PAVEMENT SECTIONS AND ON THE LOW SIDE OF SUPERELEVATED PAVEMENT.
5. CATCH BASIN, TYPE G-3 MODIFIED SHALL BE PROVIDED WITH A REINFORCED CONCRETE SLAB TOP AS DETAILED ON THIS DRAWING. THE 9'-0" MAXIMUM HEIGHT INCLUDES THE CONCRETE SLAB TOP.
6. TYPE G-2 FRAME AND GRATE SHALL BE NEENAH R-3508-A2, EAST JORDAN IRON WORKS 7300 OR APPROVED EQUAL.
7. TYPE G-3 FRAME AND GRATE SHALL BE NEENAH INLET FOR ROLL TYPE CURB R-3501-U OR EAST JORDAN IRON WORKS 7545 OR APPROVED EQUAL.
8. TYPE G-3, MODIFIED FRAME AND GRATE SHALL BE NEENAH INLET FOR ROLL TYPE CURB SPECIAL R-3501-U1, EAST JORDAN IRON WORKS 7546 OR APPROVED EQUAL.
9. TYPE G-2, MODIFIED FRAME AND GRATE FOR ROLL TYPE CURB R-3508-B2 OR APPROVED EQUAL.
10. MORTAR OR SEALER SHALL BE USED WHEN A PRECAST REINFORCED CONCRETE LID IS USED.
11. REINFORCEMENT BARS DESIGNATED (E) SHALL BE EPOXY COATED.
12. E.O.P. = EDGE OF PAVEMENT.
13. ALL CONCRETE SHALL BE CLASS SI CONCRETE.
14. FRAME AND GRATE RIM ELEVATION AND OFFSET MEASURED AT THE EDGE OF SHOULDER.
15. THE CONTRACTOR SHALL CLEARLY MARK EACH CATCH BASIN WITH "ILLINOIS TOLLWAY", CONTRACT NUMBER, STRUCTURE NUMBER, PRODUCER NAME AND DATE OF MANUFACTURE. THIS INFORMATION SHALL BE MARKED ON THE OUTSIDE FACE OF THE STRUCTURE IN A VISIBLE SURFACE AS DESIGNATED BY THE ENGINEER. THE MARKING SHALL BE PAINTED/STAMPED IN THE STRUCTURE WITH WATERPROOF PAINT/INK OR RECESSED IN THE STRUCTURE BY 1/2". THE LETTERS SHALL BE CAPITALS, NOT LESS THAN 2 IN. AND NOT MORE THAN 3 IN. IN HEIGHT.
16. A MINIMUM OF 9" OF MONOLITHIC REINFORCED CONCRETE SHALL BE MAINTAINED ABOVE PIPE PENETRATION HOLES.

NOTE:  
POSITION OF OPENING VARIES FROM 3'-2" TO 5'-4" MEASURED FROM BACK OF GUTTER LINE.

APPROVED BY: *Manar Nashif* DATE: 03/01/2026  
CHIEF ENGINEERING OFFICER

REVISIONS	
DATE	DESCRIPTION
03-01-2026	REVISED NOTE 5 (SHEET 1)
03-01-2024	REVISED NOTE 16 (SHEET 1) NOTE 11 (SHEETS 2 AND 3).
03-01-2022	ADDED NOTES FOR MARKINGS AND MINIMUM 9" ABOVE PIPE PENETRATION HOLES

**CATCH BASINS TYPE G AND TYPE G-3 MODIFIED, FRAMES AND GRATES**

VERSION: 2026-03 STANDARD: B8-10 SHEET: 1 OF 4

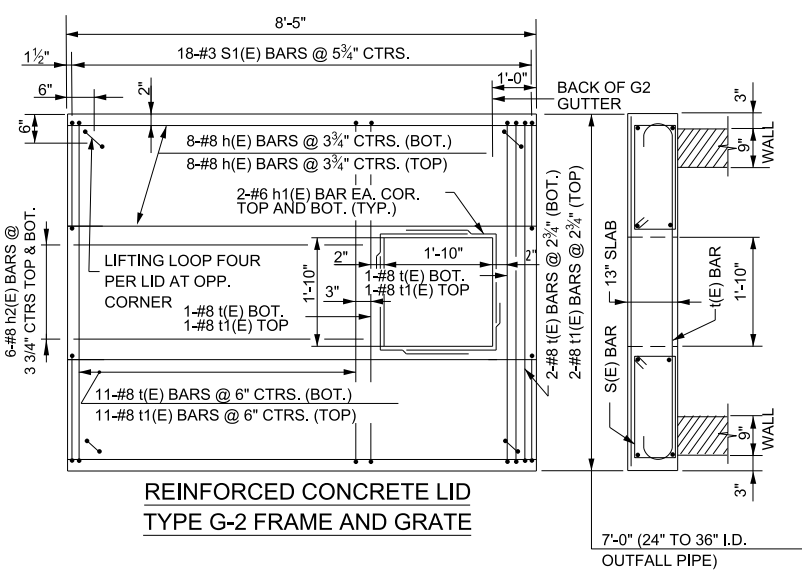
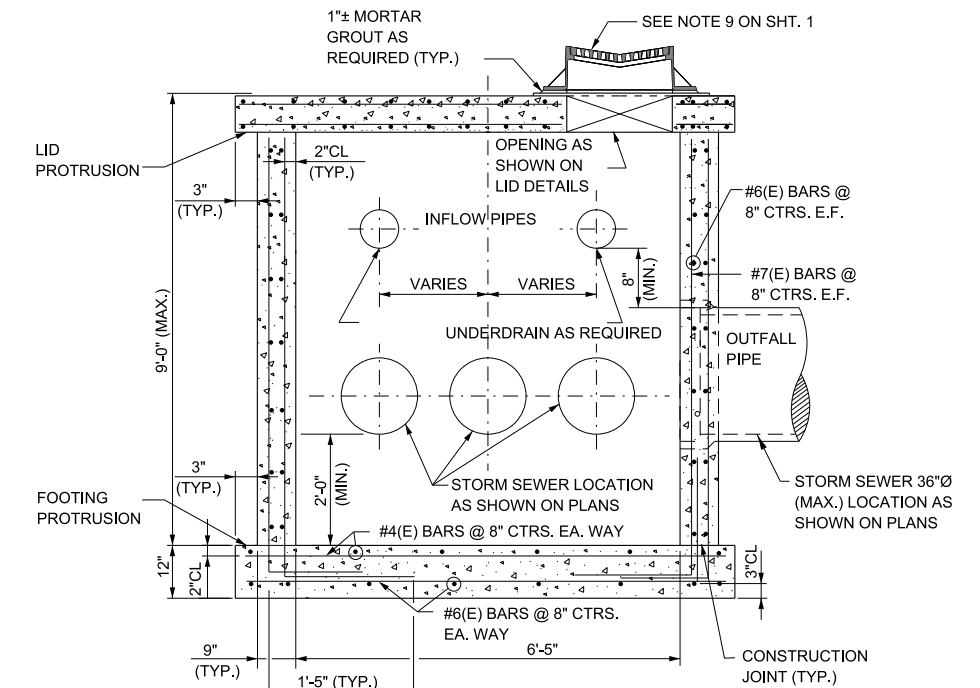
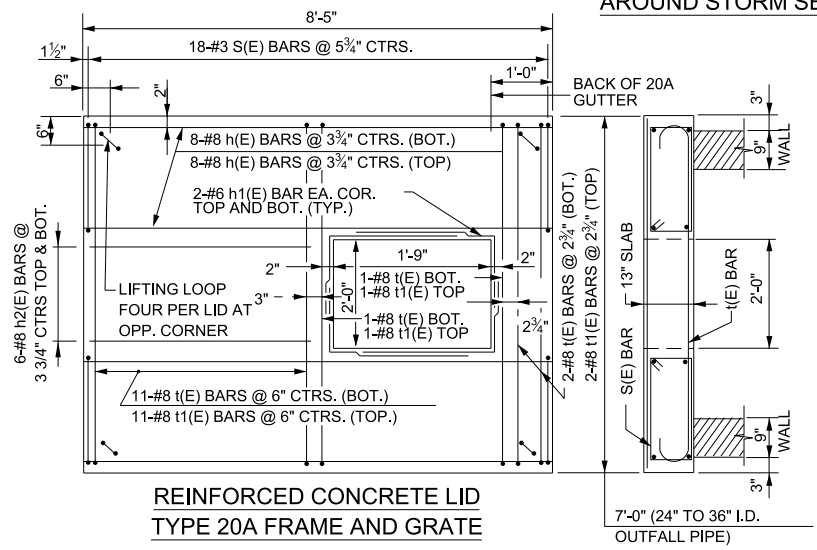
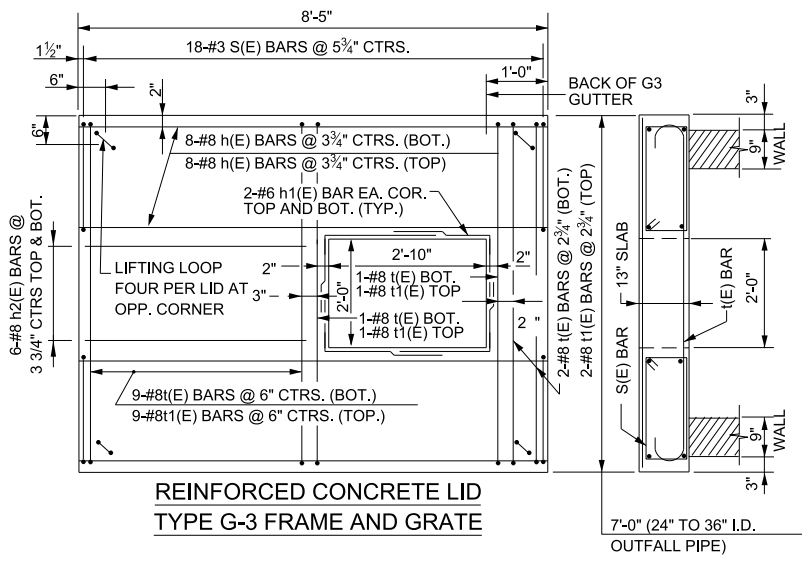
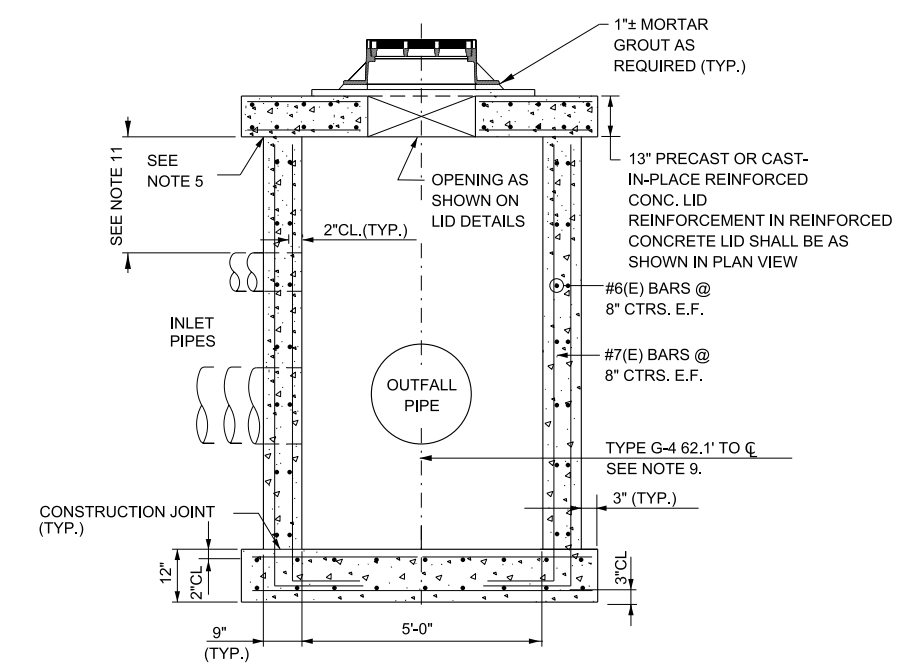
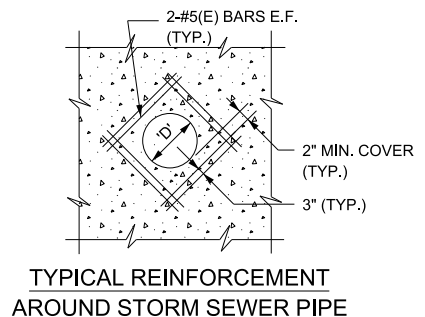
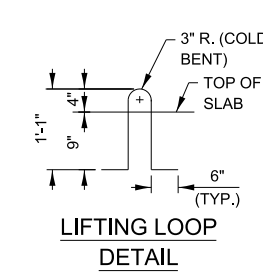
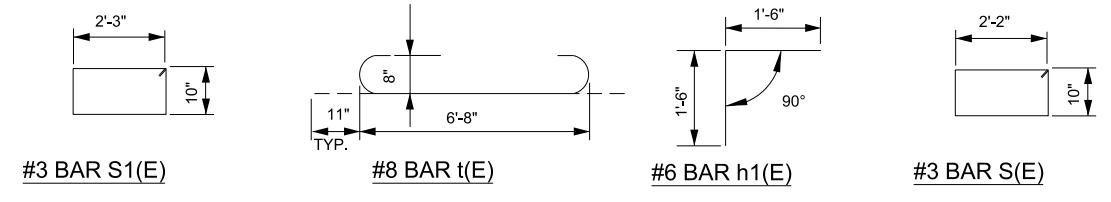
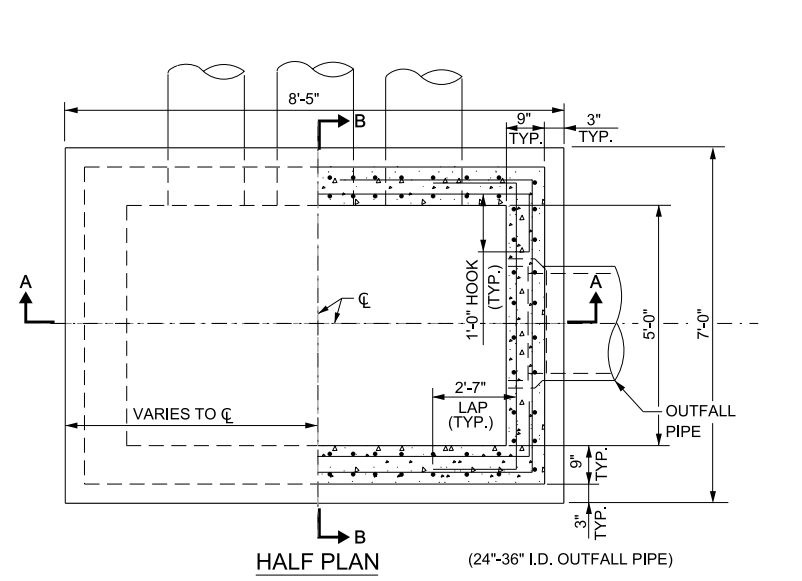

**NOTES:**

- SEE SHEET 1 OF THIS SERIES FOR ADDITIONAL NOTES.
- CATCH BASINS TYPE G-4 SHALL BE USED IN TANGENT SECTIONS AND ON THE LOW SIDE OF SUPERELEVATED PAVEMENT.
- CATCH BASINS TYPE G-4 SHALL BE PROVIDED WITH A REINFORCED CONCRETE SLAB TOP AS DETAILED ON THIS DRAWING.
- CATCH BASINS TYPE G-4 SHALL BE USED WHEN GUTTER, TYPE G-3 IS PROVIDED.
- MORTAR OR SEALER SHALL BE USED WHEN A PRECAST REINFORCED CONCRETE LID IS USED.
- FRAME AND GRATE RIM ELEVATION AND OFFSET MEASURED AT THE EDGE OF SHOULDER.
- 36"Ø MAX. OUTFALL PIPE FOR TYPE G-4 CATCH BASIN.
- ALL CONCRETE SHALL BE CLASS SI CONCRETE.
- DISTANCE FROM  $\bar{C}$  OUTFALL PIPE TO  $\bar{C}$  ROADWAY TO BE VERIFIED BY ENGINEER.
- THE CONTRACTOR SHALL CLEARLY MARK EACH CATCH BASIN WITH "ILLINOIS TOLLWAY", CONTRACT NUMBER, STRUCTURE NUMBER, PRODUCER NAME AND DATE OF MANUFACTURE. THIS INFORMATION SHALL BE MARKED ON THE OUTSIDE FACE OF THE STRUCTURE IN A VISIBLE SURFACE AS DESIGNATED BY THE ENGINEER. THE MARKING SHALL BE PAINTED/STAMPED IN THE STRUCTURE WITH WATERPROOF PAINT/INK OR RECESSED IN THE STRUCTURE BY 1/2". THE LETTERS SHALL BE CAPITALS, NOT LESS THAN 2 IN. AND NOT MORE THAN 3 IN. IN HEIGHT.
- A MINIMUM OF 9" OF MONOLITHIC REINFORCED CONCRETE SHALL BE MAINTAINED ABOVE PIPE PENETRATION HOLES.

APPROVED BY: *Manar Nashif* CHIEF ENGINEERING OFFICER  
 DATE: 03/01/2026

**CATCH BASINS TYPE G AND TYPE G-3 MODIFIED, FRAMES AND GRATES**

VERSION: 2026-03      STANDARD: B8-10      SHEET: 2 OF 4

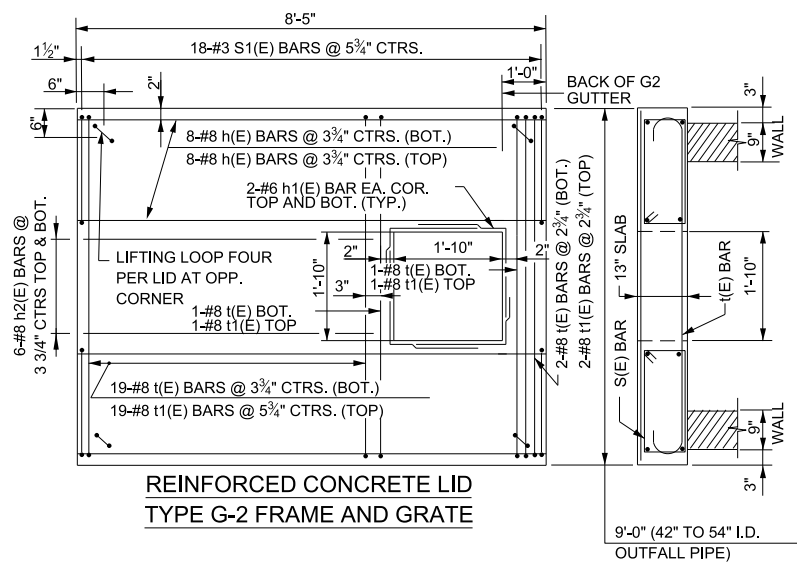
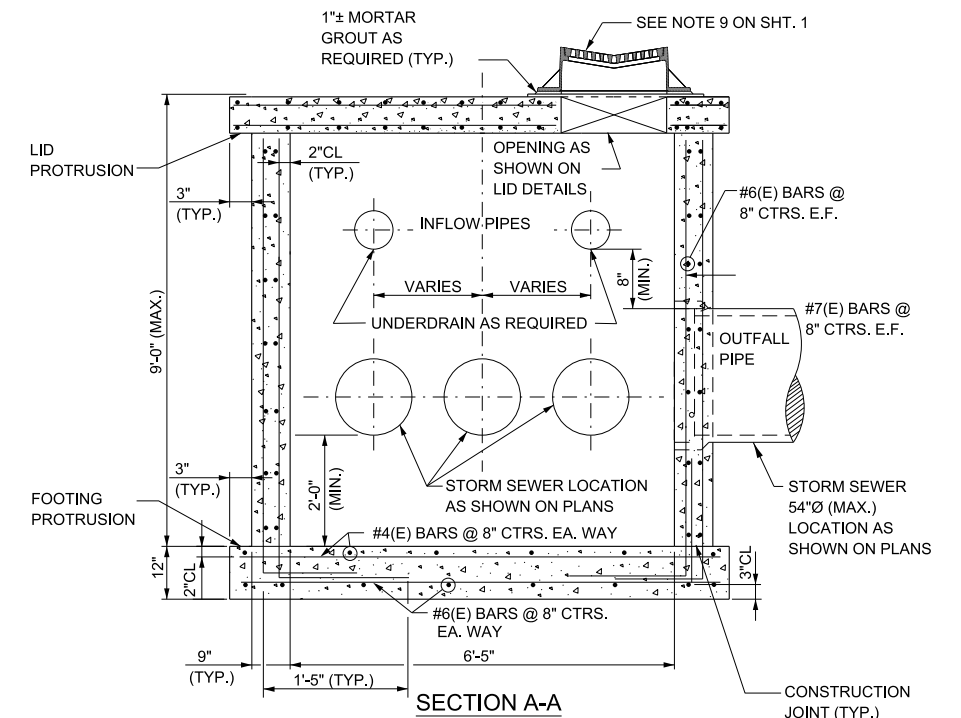
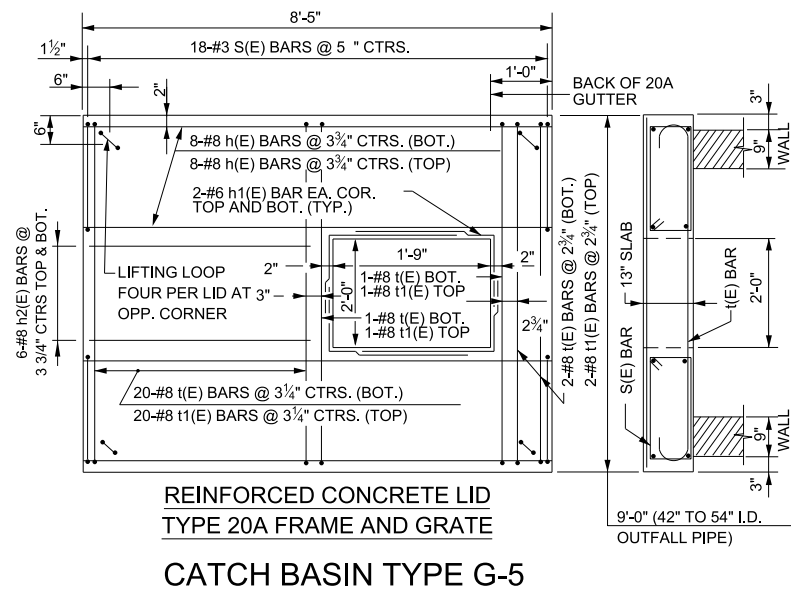
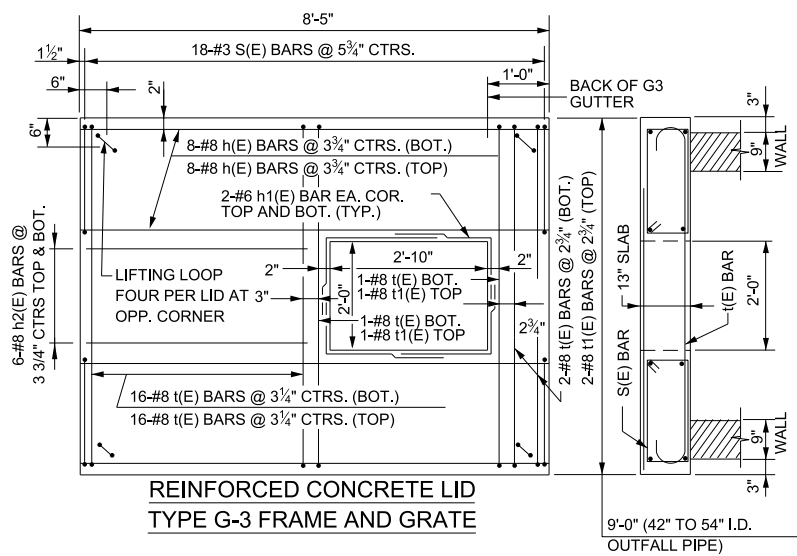
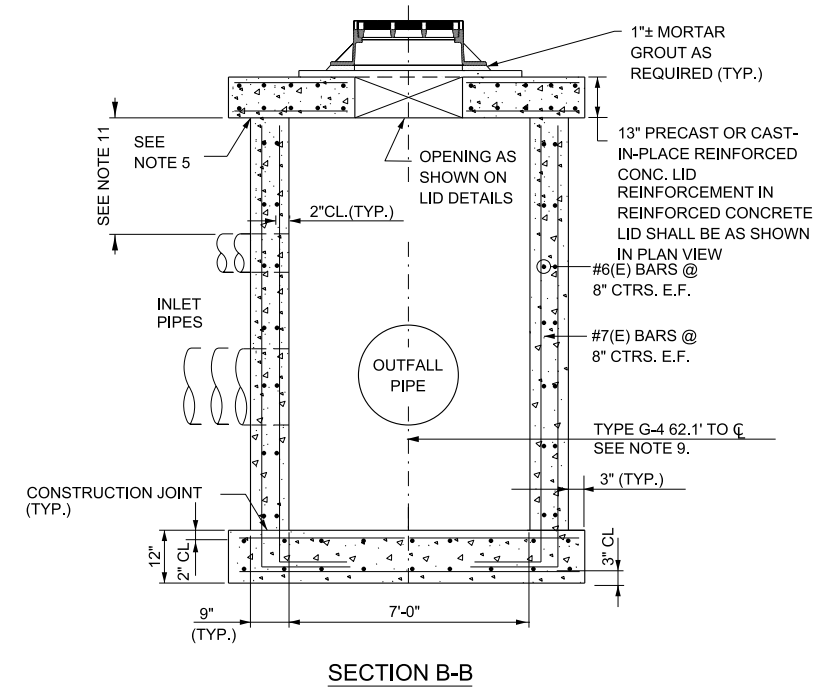
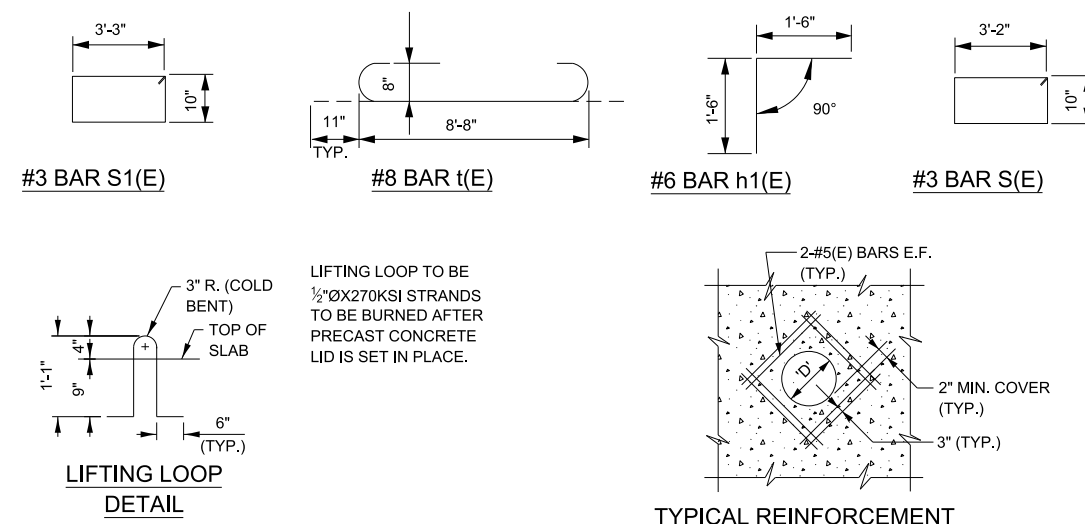
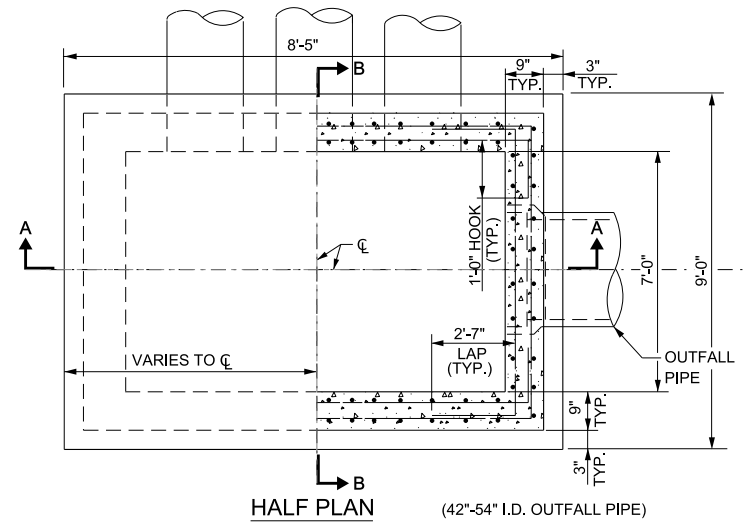

**NOTES:**

- SEE SHEET 1 OF THIS SERIES FOR ADDITIONAL NOTES.
- CATCH BASINS TYPE G-5 SHALL BE USED IN TANGENT SECTIONS AND ON THE LOW SIDE OF SUPERELEVATED PAVEMENT.
- CATCH BASINS TYPE G-5 SHALL BE PROVIDED WITH A REINFORCED CONCRETE SLAB TOP AS DETAILED ON THIS DRAWING.
- CATCH BASINS TYPE G-5 SHALL BE USED WHEN GUTTER, TYPE G-3 IS PROVIDED.
- MORTAR OR SEALER SHALL BE USED WHEN A PRECAST REINFORCED CONCRETE LID IS USED.
- FRAME AND GRATE RIM ELEVATION AND OFFSET MEASURED AT THE EDGE OF SHOULDER.
- 54"Ø MAX. OUTFALL PIPE FOR TYPE G-5 CATCH BASIN.
- ALL CONCRETE SHALL BE CLASS SI CONCRETE.
- DISTANCE FROM  $\phi$  OUTFALL PIPE TO  $\sim$  ROADWAY TO BE VERIFIED BY ENGINEER.
- THE CONTRACTOR SHALL CLEARLY MARK EACH CATCH BASIN WITH "ILLINOIS TOLLWAY", CONTRACT NUMBER, STRUCTURE NUMBER, PRODUCER NAME AND DATE OF MANUFACTURE. THIS INFORMATION SHALL BE MARKED ON THE OUTSIDE FACE OF THE STRUCTURE IN A VISIBLE SURFACE AS DESIGNATED BY THE ENGINEER. THE MARKING SHALL BE PAINTED/STAMPED IN THE STRUCTURE WITH WATERPROOF PAINT/INK OR RECESSED IN THE STRUCTURE BY 1/2". THE LETTERS SHALL BE CAPITALS, NOT LESS THAN 2 IN. AND NOT MORE THAN 3 IN. IN HEIGHT.
- A MINIMUM OF 9" OF MONOLITHIC REINFORCED CONCRETE SHALL BE MAINTAINED ABOVE PIPE PENETRATION HOLES.

APPROVED BY: *Manar Nashif* CHIEF ENGINEERING OFFICER  
 DATE: 03/01/2026

**CATCH BASINS TYPE G AND TYPE G-3 MODIFIED, FRAMES AND GRATES**

VERSION: 2026-03      STANDARD: B8-10      SHEET: 3 OF 4

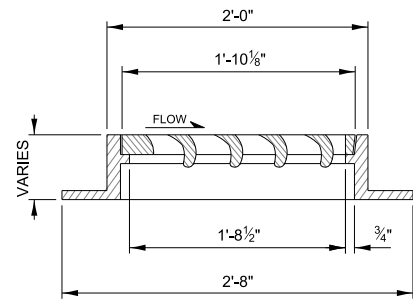

SECTION T-T

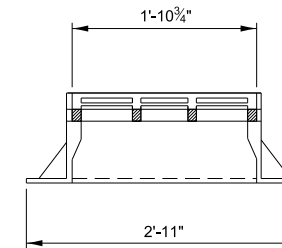

SECTION Y-Y

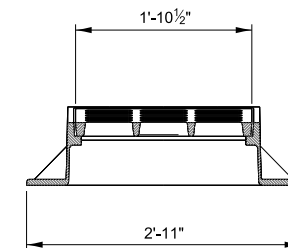

SECTION S-S

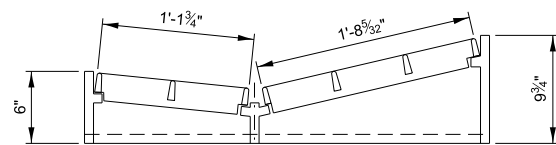

SECTION U-U

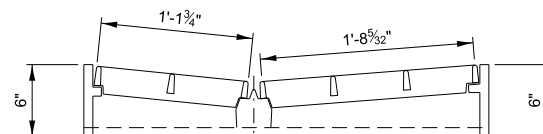

SECTION W-W

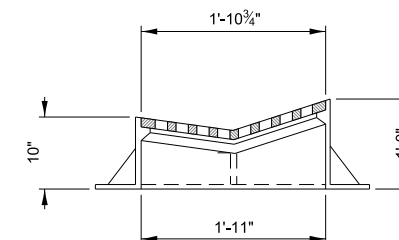

SECTION Z-Z

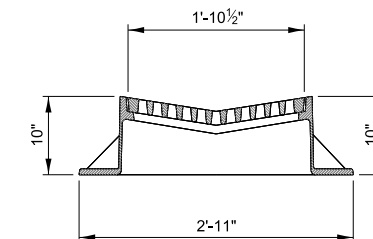

SECTION V-V

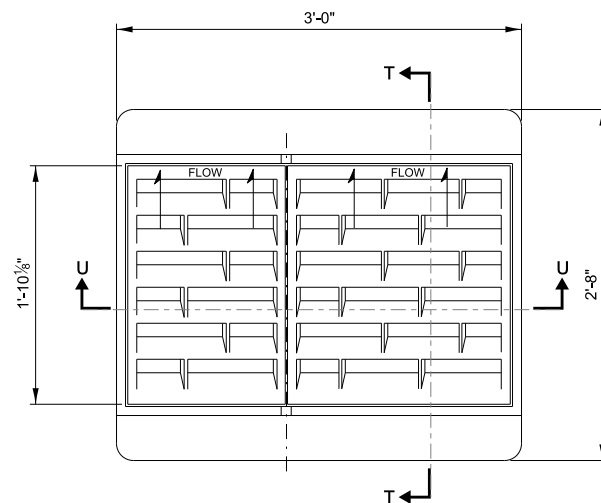

TYPE G-3 FRAME & GRATE

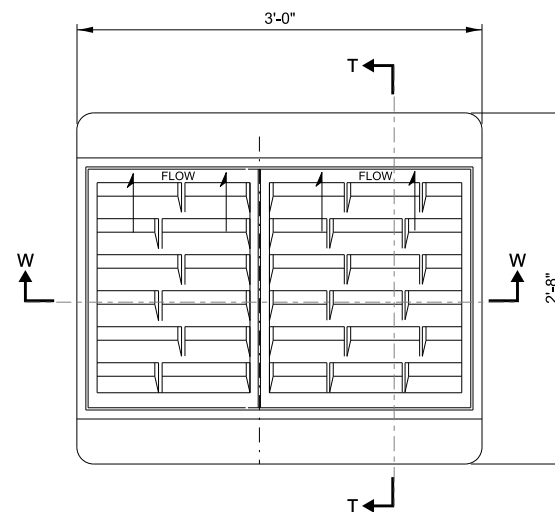

TYPE G-3, MODIFIED  
FRAME & GRATE

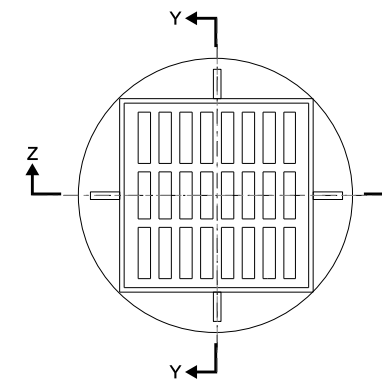

TYPE G-2 FRAME & GRATE

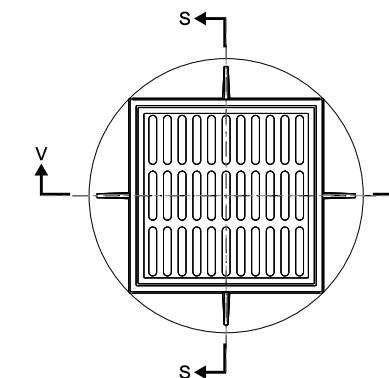

TYPE G-2 MODIFIED  
FRAME & GRATE

NOTE:

SEE SHEET 1 OF THIS SERIES FOR NOTES.

APPROVED BY: *Manar Nashif*  
CHIEF ENGINEERING OFFICER  
DATE: 03/01/2026



CATCH BASINS TYPE G AND  
TYPE G-3 MODIFIED, FRAMES  
AND GRATES

VERSION: 2026-03 STANDARD: B8-10 SHEET: 4 OF 4

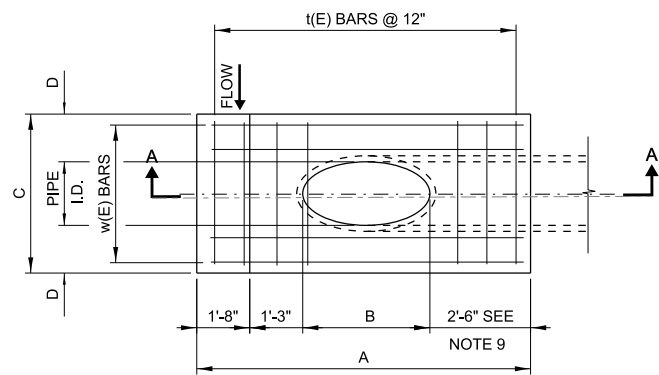

PLAN I

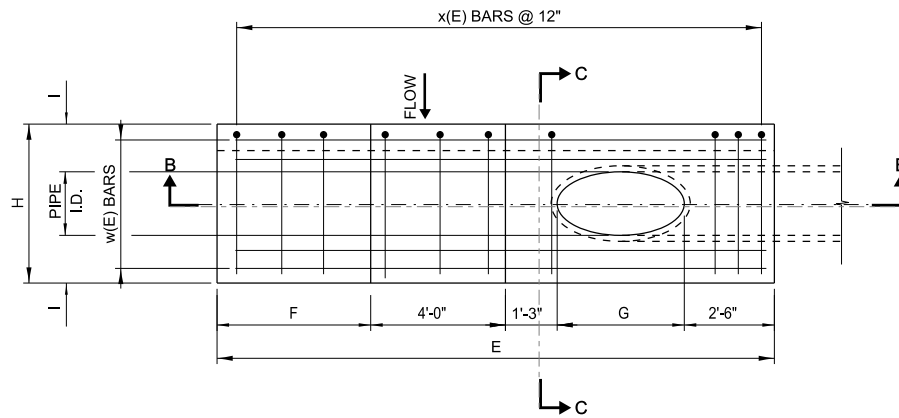

PLAN II

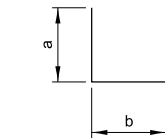

x(E) BARS

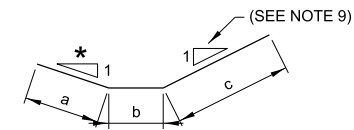

w(E) BARS

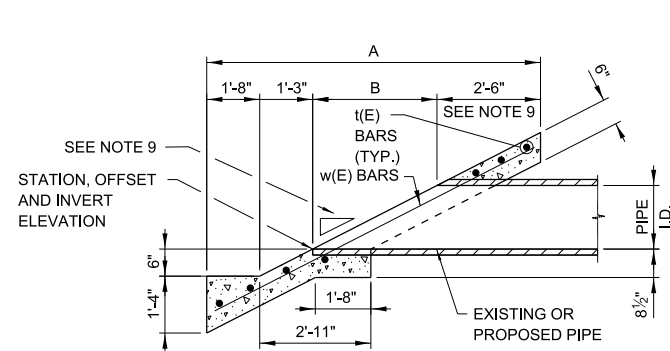

SECTION A-A

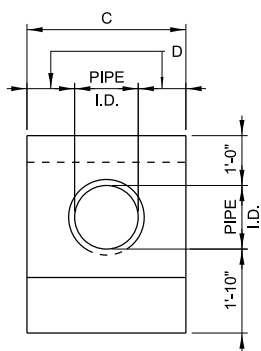

ELEVATION

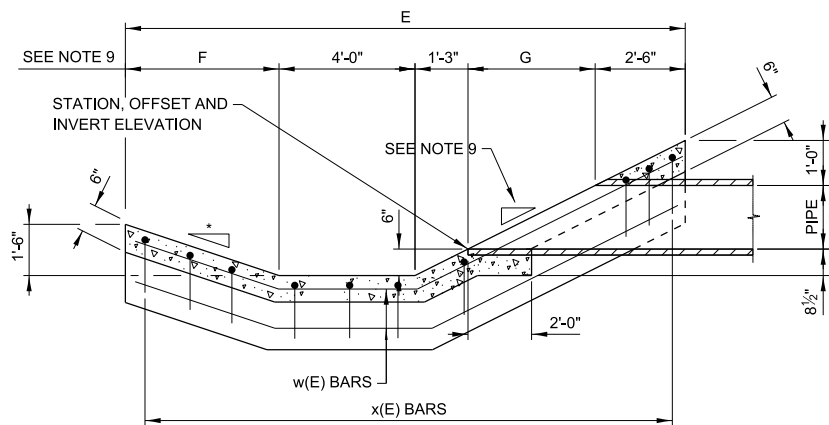

SECTION B-B

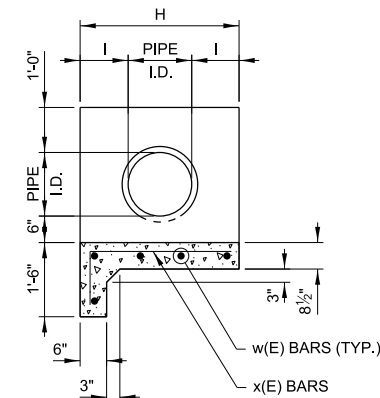

SECTION C-C

\* MATCH EXISTING OR PROPOSED SLOPE, SEE NOTE 9

NOTES:

- SLOPED HEADWALL TYPES I AND II SHALL BE CONSTRUCTED FLUSH WITH EXISTING OR PROPOSED SLOPE.
- CLASS SI CONCRETE SHALL BE USED THROUGHOUT.
- ALL REINFORCEMENT BARS SHOWN SHALL BE EPOXY COATED (E).
- BAR BENDING DETAILS ARE DIMENSIONED OUT TO OUT OF BARS.
- ALL EXPOSED EDGES SHALL HAVE A 3/4" CHAMFER. CHAMFER ON VERTICAL EDGES SHALL BE CONTINUED A MINIMUM OF ONE FOOT BELOW THE FINISHED GROUND LINE.
- COVER FROM THE FACE OF CONCRETE TO FACE OF REINFORCEMENT BARS SHALL BE 3" FOR SURFACES FORMED AGAINST EARTH AND 2" FOR ALL OTHER SURFACES UNLESS OTHERWISE SHOWN.
- CARE SHALL BE EXERCISED IN REMOVING ANY LENGTH OF EXISTING PIPE SO THE REMAINING PIPE IS UNDATED AND FULLY FUNCTIONING.
- ALL SLOPES ARE EXPRESSED AS UNITS OF VERTICAL DISPLACEMENT TO UNITS OF HORIZONTAL DISPLACEMENT (V:H).
- SLOPED HEADWALLS, TYPES I AND II TO BE USED ONLY FOR SLOPES STEEPER THAN 1:3. DIMENSIONS AND QUANTITIES SHOWN ARE BASED ON A 1:2.5 SLOPE (EXISTING AND PROPOSED).
- I.D. DENOTES INSIDE DIAMETER OF PIPE. O.D. DENOTES OUTSIDE DIAMETER OF PIPE.

TABLES FOR DIMENSIONS, REINFORCEMENT AND QUANTITIES FOR ONE SLOPED HEADWALL TYPE I

PIPE I.D.	A	B	C	D
6"	6'-8"	1'-3"	2'-6"	1'-0"
12"	7'-11"	2'-6"	3'-0"	1'-0"
15"	8'-7"	3'-2"	3'-9"	1'-3"
18"	9'-2"	3'-9"	4'-6"	1'-6"

PIPE I.D.	REINFORCEMENT BARS		
	MARK(E)	NO. & SIZE	LENGTH
6"	t6	7-#4	2'-2"
	w6	4-#4	6'-8"
12"	t12	7-#4	2'-8"
	w12	4-#4	8'-2"
15"	t15	7-#4	3'-5"
	w15	4-#4	8'-11"
18"	t18	7-#4	4'-2"
	w18	4-#4	9'-6"

DESIGN NO.	INSIDE DIA. OF PIPE	CONC. 1 HDWL. (CU. YD.)	REINF. BARS. 1 HDWL. (POUND)
F-6-2	6"	0.5	29
F-12-2	12"	0.6	35
F-15-2	15"	0.8	40
F-18-2	18"	1.0	45

PIPE I.D.	E	F	G	H	I
12"	14'-0"	3'-9"	2'-6"	3'-0"	1'-0"
15"	14'-8"	3'-9"	3'-2"	3'-9"	1'-3"
18"	15'-3"	3'-9"	3'-9"	4'-6"	1'-6"

TABLES FOR DIMENSIONS, REINFORCEMENT AND QUANTITIES FOR ONE SLOPED HEADWALL TYPE II

PIPE I.D.	REINFORCEMENT BARS					
	MARK(E)	NO. & SIZE	LENGTH	a	b	c
12"	x12	10-#4	3'-6"	2'-6"	1'-0"	---
	w12	5-#4	14'-4"	3'-10"	4'-0"	6'-6"
15"	x15	10-#4	4'-3"	3'-3"	1'-0"	---
	w15	5-#4	15'-1"	3'-10"	4'-0"	7'-3"
18"	x18	10-#4	5'-0"	4'-0"	1'-0"	---
	w18	5-#4	15'-8"	3'-10"	4'-0"	7'-10"

DESIGN NO.	INSIDE DIA. OF PIPE	CONC. 1 HDWL. (CU. YD.)	REINF. BARS. 1 HDWL. (POUND)
E-12-2	12"	1.2	75
E-15-2	15"	1.6	82
E-18-2	18"	1.7	89

SLOPED HEADWALL TYPE I

SLOPED HEADWALL TYPE II

APPROVED BY: *Paul Kovacs* CHIEF ENGINEERING OFFICER  
DATE: 03/31/2017

REVISIONS	
DATE	DESCRIPTION
03-31-2017	REVISED REINFORCEMENT BARS, TABLES
03-11-2015	REVISED REINFORCEMENT BARS, TABLES
03-31-2014	REVISED CONCRETE QUANTITIES REINFORCEMENT STEEL

**SLOPED HEADWALLS TYPE I AND TYPE II**

VERSION: 2017-03      STANDARD: B9-04      SHEET: 1 OF 1

DIMENSIONS AND QUANTITIES FOR ONE SLOPED HEADWALL TYPE III

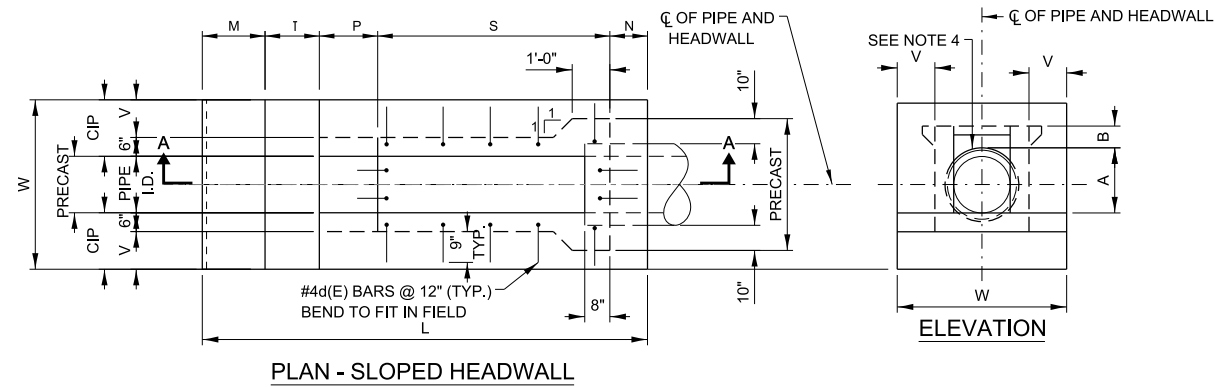

NOTES:  
EACH #4d(E) BAR SHALL BE PLACED SUCH THAT IT WILL PROJECT 9" INTO THE CAST IN PLACE (CIP) CONCRETE AND IT SHALL BE 3" BELOW THE TOP SURFACE. HOOKS IN THE PRECAST SECTION SHALL BE TIPPED TO CLEAR ALL CONCRETE SURFACES A MIN. OF 2".

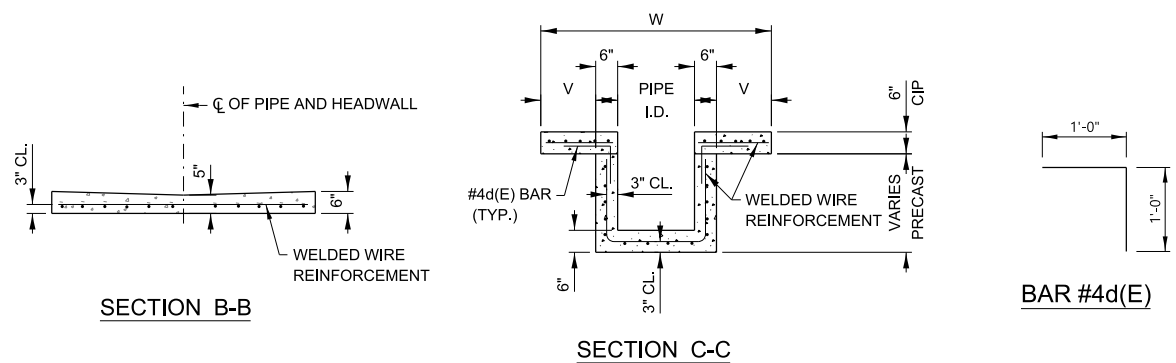
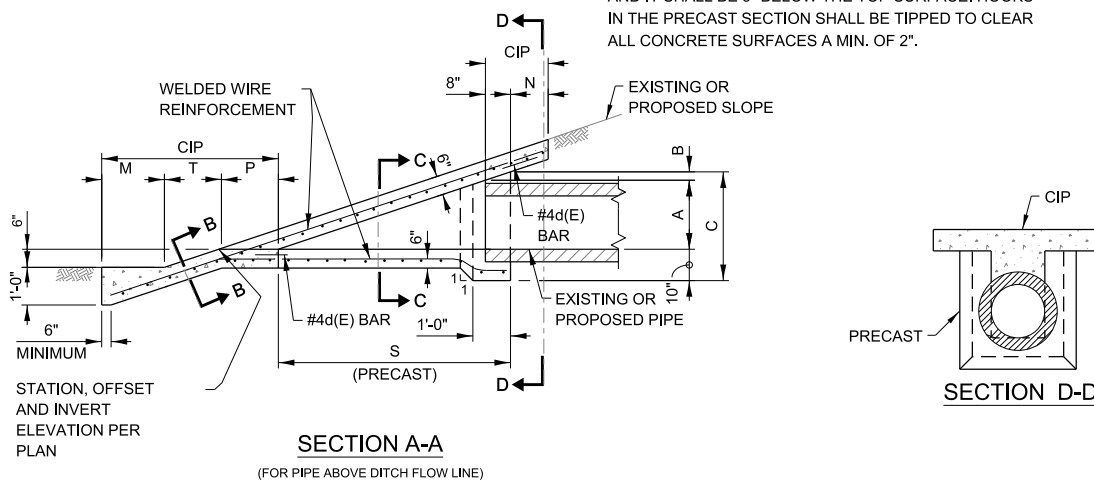

NOTES:

1. THE CAST IN PLACE (CIP) SLOPED HEADWALL SHALL BE CONSTRUCTED FLUSH WITH EXISTING OR PROPOSED SLOPE.
2. CLASS SI CONCRETE SHALL BE USED THROUGHOUT.
3. WELDED WIRE REINFORCEMENT SHALL BE EPOXY COATED 4x4-W4xW4, 58 LBS. PER 100 SQ.FT.
4. ALL REINFORCEMENT BARS SHOWN SHALL BE EPOXY COATED (E).
5. BAR BENDING DETAILS ARE DIMENSIONED OUT TO OUT OF BARS.
6. COVER FROM FACE OF CONCRETE TO FACE OF REINFORCEMENT BAR SHALL BE 3" FOR SURFACES FORMED AGAINST EARTH AND 2" FOR ALL OTHER SURFACES UNLESS OTHERWISE SHOWN.
7. PRECAST UNIT USE IS OPTIONAL. THE ENTIRE STRUCTURE MAY BE CAST IN PLACE.

PIPE I.D.	DIMENSIONS											PRE CAST CONC. CU. YD.	CAST-IN-PLACE CU. YD.	WELDED WIRE REINFORCEMENT SQ. YD.	REINFORCEMENT BARS				
	A	B	C	N	M	T	P	S	L	V	W				MARK(E)	SIZE	NO.	LENGTH	LB.
6"	9"	2 3/4"	1'-9 3/4"	1'-0"	1'-8"	1'-6"	1'-6 3/4"	2'-11 1/4"	8'-8"	1'-0"	3'-6"	0.15	0.72	3.28	d6	#4	12	2'-0"	16
8"	11"	2 3/4"	1'-11 3/4"	1'-0"	1'-8"	1'-6"	1'-6 3/4"	3'-5 1/4"	9'-2"	1'-0"	3'-8"	0.22	0.75	3.89	d8	#4	12	2'-0"	16
12"	1'-3 1/2"	2 3/4"	2'-4 1/4"	1'-0"	1'-8"	1'-6"	1'-6 3/4"	4'-6 3/4"	10'-3 1/2"	1'-0"	4'-0"	0.34	0.92	4.50	d12	#4	14	2'-0"	19
15"	1'-6 1/2"	2 3/4"	2'-7 1/4"	1'-0"	1'-8"	1'-6"	1'-6 3/4"	5'-3 3/4"	11'-1 1/2"	1'-0"	4'-3"	0.45	1.01	5.88	d15	#4	16	2'-0"	21
18"	1'-10"	2 3/4"	2'-10 3/4"	1'-0"	1'-8"	1'-6"	1'-6 3/4"	6'-2 1/4"	11'-11"	1'-0"	4'-6"	0.61	1.13	6.44	d18	#4	18	2'-0"	24
21"	2'-1"	2 3/4"	3'-1 3/4"	1'-0"	1'-9"	1'-6"	1'-6 3/4"	6'-11 1/4"	12'-9"	1'-3"	5'-3"	0.76	1.39	8.34	d21	#4	22	2'-0"	29
24"	2'-4 1/2"	2 3/4"	3'-5 1/4"	1'-0"	2'-0"	1'-6"	1'-6 3/4"	7'-9 3/4"	13'-10 1/2"	1'-6"	6'-0"	0.95	1.72	9.85	d24	#4	24	2'-0"	32
27"	2'-7 1/2"	2 3/4"	3'-8 1/4"	1'-1 1/2"	2'-3"	1'-6"	1'-6 3/4"	8'-6 3/4"	15'-0"	1'-9"	6'-9"	1.14	2.07	13.54	d27	#4	24	2'-0"	32
30"	2'-11"	2 3/4"	3'-11 3/4"	1'-3"	2'-6"	1'-6"	1'-6 3/4"	9'-5 1/4"	16'-3"	2'-0"	7'-6"	1.38	2.46	16.40	d30	#4	26	2'-0"	35

PIPE I.D.	DIMENSIONS											PRE CAST CONC. CU. YD.	CAST-IN-PLACE CU. YD.	WELDED WIRE REINFORCEMENT SQ. YD.	REINFORCEMENT BARS				
	A	B	C	N	M	T	P	S	L	V	W				MARK(E)	SIZE	NO.	LENGTH	LB.
6"	9"	2"	1'-9"	1'-0"	1'-8"	2'-0"	2'-1"	3'-8"	10'-5"	1'-0"	3'-6"	0.17	0.83	4.07	d6	#4	12	2'-0"	16
8"	11"	2"	1'-11"	1'-0"	1'-8"	2'-0"	2'-1"	4'-4"	11'-1"	1'-0"	3'-8"	0.28	0.87	4.97	d8	#4	14	2'-0"	19
12"	1'-3 1/2"	2"	2'-3 1/2"	1'-0"	1'-8"	2'-0"	2'-1"	5'-10"	12'-7"	1'-0"	4'-0"	0.41	1.07	5.50	d12	#4	16	2'-0"	21
15"	1'-6 1/2"	2"	2'-6 1/2"	1'-0"	1'-8"	2'-0"	2'-1"	6'-10"	13'-7"	1'-0"	4'-3"	0.55	1.18	6.63	d15	#4	18	2'-0"	24
18"	1'-10"	2"	2'-10"	1'-0"	1'-8"	2'-0"	2'-1"	8'-0"	14'-9"	1'-0"	4'-6"	0.74	1.32	8.60	d18	#4	22	2'-0"	29
21"	2'-1"	2"	3'-1"	1'-0"	1'-9"	2'-0"	2'-1"	9'-0"	15'-10"	1'-3"	5'-3"	0.93	1.63	11.03	d21	#4	24	2'-0"	32
24"	2'-4 1/2"	2"	3'-4 1/2"	1'-0"	2'-0"	2'-0"	2'-1"	10'-2"	17'-3"	1'-6"	6'-0"	1.18	2.00	13.88	d24	#4	28	2'-0"	37
27"	2'-7 1/2"	2"	3'-7 1/2"	1'-1 1/2"	2'-3"	2'-0"	2'-1"	11'-2"	18'-7 1/2"	1'-9"	6'-9"	1.42	2.41	14.83	d27	#4	30	2'-0"	40
30"	2'-11"	2"	3'-11"	1'-3"	2'-6"	2'-0"	2'-1"	12'-4"	20'-2"	2'-0"	7'-6"	1.71	2.87	20.49	d30	#4	32	2'-0"	43

PIPE I.D.	DIMENSIONS											PRE CAST CONC. CU. YD.	CAST-IN-PLACE CU. YD.	WELDED WIRE REINFORCEMENT SQ. YD.	REINFORCEMENT BARS				
	A	B	C	N	M	T	P	S	L	V	W				MARK(E)	SIZE	NO.	LENGTH	LB.
6"	9"	1 1/2"	1'-8 1/2"	1'-0"	1'-8"	3'-0"	3'-0"	5'-3"	13'-11"	1'-0"	3'-6"	0.23	1.07	5.29	d6	#4	16	2'-0"	21
8"	11"	1 1/2"	1'-10 1/2"	1'-0"	1'-8"	3'-0"	3'-0"	6'-3"	14'-11"	1'-0"	3'-8"	0.43	1.13	7.13	d8	#4	18	2'-0"	24
12"	1'-3 1/2"	1 1/2"	2'-3"	1'-0"	1'-8"	3'-0"	3'-0"	8'-6"	17'-2"	1'-0"	4'-0"	0.57	1.38	8.62	d12	#4	22	2'-0"	29
15"	1'-6 1/2"	1 1/2"	2'-6"	1'-0"	1'-8"	3'-0"	3'-0"	10'-0"	18'-8"	1'-0"	4'-3"	0.77	1.53	10.35	d15	#4	26	2'-0"	35
18"	1'-10"	1 1/2"	2'-9 1/2"	1'-0"	1'-8"	3'-0"	3'-0"	11'-9"	20'-5"	1'-0"	4'-6"	1.04	1.70	12.47	d18	#4	28	2'-0"	37
21"	2'-1"	1 1/2"	3'-0 1/2"	1'-0"	1'-9"	3'-0"	3'-0"	13'-3"	22'-0"	1'-3"	5'-3"	1.31	2.11	15.77	d21	#4	34	2'-0"	45
24"	2'-4 1/2"	1 1/2"	3'-4"	1'-0"	2'-0"	3'-0"	3'-0"	15'-0"	24'-0"	1'-6"	6'-0"	1.66	2.59	17.62	d24	#4	38	2'-0"	51
27"	2'-7 1/2"	1 1/2"	3'-7"	1'-1 1/2"	2'-3"	3'-0"	3'-0"	16'-6"	25'-10 1/2"	1'-9"	6'-9"	1.99	3.11	24.10	d27	#4	40	2'-0"	53
30"	2'-11"	1 1/2"	3'-10 1/2"	1'-3"	2'-6"	3'-0"	3'-0"	18'-3"	28'-0"	2'-0"	7'-6"	2.41	3.70	29.13	d30	#4	44	2'-0"	59

8. AFTER THE PRECAST SLOPED HEADWALL HAS BEEN PLACED, THE SPACE BETWEEN THE HEADWALL AND PIPE SHALL BE COMPLETELY FILLED WITH AN APPROVED NON-SHRINK GROUT WITH A MINIMUM COMPRESSIVE STRENGTH IN ACCORDANCE WITH THE STANDARD SPECIFICATIONS.
9. THE SLOPED HEADWALL DETAILS SHOWN ON THIS DRAWING ARE FOR USE ONLY WITH PIPES HAVING DIAMETER OR SPAN OF 30" OR LESS.
10. ALL SLOPES ARE EXPRESSED AS UNITS OF VERTICAL DISPLACEMENT TO UNITS OF HORIZONTAL DISPLACEMENT (V:H).
11. I.D. DENOTES INSIDE DIAMETER OF PIPE. O.D. DENOTES OUTSIDE DIAMETER OF PIPE.
12. REBAR REINFORCEMENT MAY BE USED AS AN OPTION TO WELDED WIRE REINFORCEMENT. DRAWINGS SHALL BE SUBMITTED FOR APPROVAL BY THE ENGINEER.

APPROVED BY: *Paul Kovacs* CHIEF ENGINEERING OFFICER  
DATE: 03/01/2022

REVISIONS	
DATE	DESCRIPTION
03-01-2022	REVISED WELDED WIRE NOTE
03-01-2021	ADDED 8" SLOPED HEADWALL TYPE III
03-01-2020	REVISED NOTES
03-01-2019	ADDED DOUBLE SLOPED HEADWALL TYPE III
03-31-2017	REVISED TABLE (L)

**Illinois Tollway**

**SLOPED HEADWALLS TYPE III DETAILS**

VERSION: 2022-03      STANDARD: B10-13      SHEET: 1 OF 3

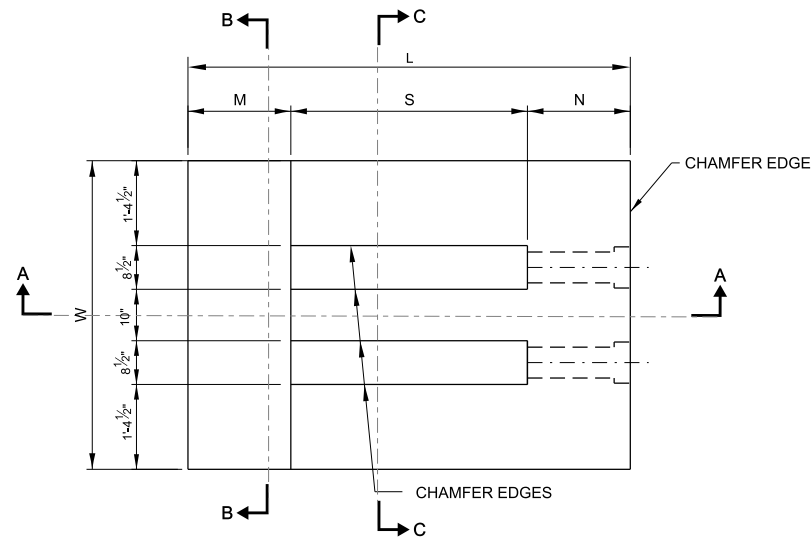

PLAN - DOUBLE SLOPED HEADWALL

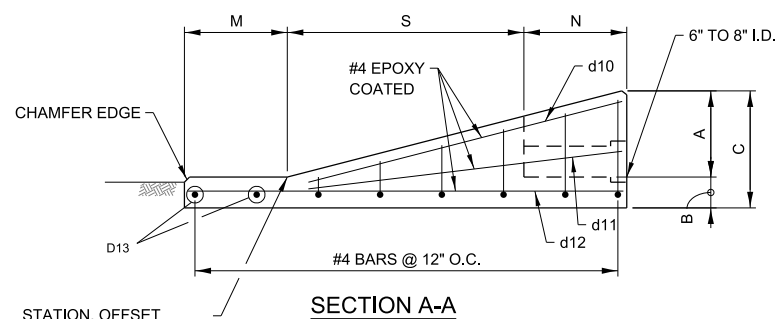

SECTION A-A

STATION, OFFSET AND INVERT ELEVATION PER PLAN

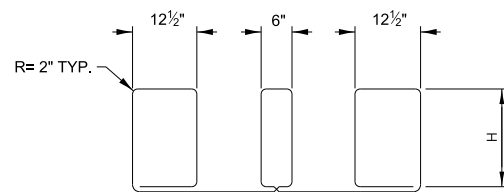

d1 THROUGH d9 BAR BENT

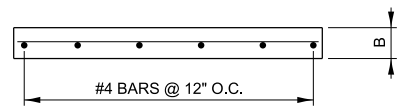

SECTION B-B

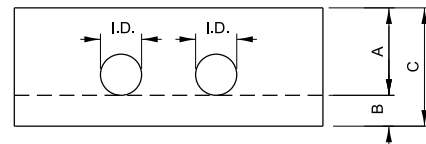

ELEVATION

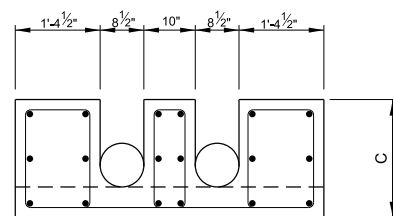

SECTION C-C

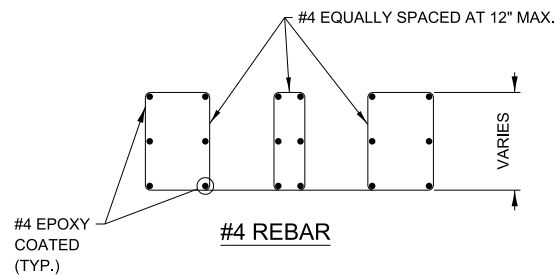

#4 REBAR

NOTES:

1. THE DOUBLE SLOPED HEADWALL SHALL BE CONSTRUCTED FLUSH WITH EXISTING OR PROPOSED SLOPE.
2. CLASS SI CONCRETE SHALL BE USED THROUGHOUT.
3. ALL REINFORCEMENT BARS SHOWN SHALL BE EPOXY COATED (E).
4. BAR BENDING DETAILS ARE DIMENSIONED OUT TO OUT OF BARS.
5. COVER FROM FACE OF CONCRETE TO FACE OF REINFORCEMENT BAR SHALL BE 3" FOR SURFACES FORMED AGAINST EARTH AND 2" FOR ALL OTHER SURFACES UNLESS OTHERWISE SHOWN.
6. PRECAST UNIT USE IS OPTIONAL. THE ENTIRE STRUCTURE MAY BE CAST IN PLACE.
7. AFTER THE PRECAST SLOPED HEADWALL HAS BEEN PLACED, THE SPACE BETWEEN THE HEADWALL AND PIPE SHALL BE COMPLETELY FILLED WITH AN APPROVED NON-SHRINK GROUT WITH A MINIMUM COMPRESSIVE STRENGTH IN ACCORDANCE WITH THE STANDARD SPECIFICATIONS.
8. THE DOUBLE SLOPED HEADWALL DETAILS SHOWN ON THIS DRAWING ARE FOR USE ONLY WITH PIPES HAVING DIAMETER OR SPAN OF 8" OR LESS.
9. ALL SLOPES ARE EXPRESSED AS UNITS OF VERTICAL DISPLACEMENT TO UNITS OF HORIZONTAL DISPLACEMENT (V:H).
10. I.D. DENOTES INSIDE DIAMETER OF PIPE.
11. WELDED WIRE REINFORCEMENT MAY BE USED AS AN OPTION TO REBAR REINFORCEMENT, DRAWINGS SHALL BE SUBMITTED FOR APPROVAL BY THE ENGINEER.

STIRRUP HEIGHT TABLE FOR DOUBLE SLOPED HEADWALL TYPE III

1 TO 3 SLOPE AND C=1'-11"		1 TO 4 SLOPE AND C=1'-11"		1 TO 6 SLOPE AND C=1'-11"	
	STIRRUP HEIGHT, H		STIRRUP HEIGHT, H		STIRRUP HEIGHT, H
d1 E	17'-6"	d1 E	17'-7"	d1 E	17'-8 1/4"
d2 E	14'-4 1/4"	d2 E	15'-3 1/4"	d2 E	15'-10 1/2"
d3 E	11'-3 3/4"	d3 E	12'-6 1/4"	d3 E	14'-1/4"
d4 E	8'-2 1/4"	d4 E	10'-1/2"	d4 E	12'-2 1/4"
d5 E	5'-1 1/2"	d5 E	7'-6"	d5 E	10'-4 1/4"
		d6 E	5'-0"	d6 E	8'-6"
				d7 E	6'-8 1/4"
				d8 E	4'-10"

1 TO 3 SLOPE AND C=2'-1"		1 TO 4 SLOPE AND C=2'-1"		1 TO 6 SLOPE AND C=2'-1"	
	STIRRUP HEIGHT, H		STIRRUP HEIGHT, H		STIRRUP HEIGHT, H
d1 E	19'-6"	d1 E	19'-7"	d1 E	19'-8 1/4"
d2 E	16'-4 1/4"	d2 E	17'-3 1/4"	d2 E	17'-10 1/2"
d3 E	13'-3 3/4"	d3 E	14'-6 1/4"	d3 E	16'-1/4"
d4 E	10'-2 1/4"	d4 E	12'-1/2"	d4 E	14'-2 1/4"
d5 E	7'-1 1/2"	d5 E	9'-6"	d5 E	12'-4 1/4"
d6 E	4'-1/2"	d6 E	7'-0"	d6 E	10'-6"
		d7 E	4'-5 3/4"	d7 E	8'-8 1/4"
				d8 E	6'-10"
				d9 E	5'-0"

APPROVED BY: *Paul Kovacs* CHIEF ENGINEERING OFFICER  
 DATE: 03/01/2022



SLOPED HEADWALLS TYPE III DETAILS

	PIPE I.D.	DIMENSIONS								PRECAST CONCRETE CU YD	MARK	SIZE	NO	LENGTH	LB
		A	B	C	N	S	M	L	W						
1 TO 3 SLOPE	(2) - 6" PIPE	1'-5"	6"	1'-11"	1'-8"	3'-10"	1'-8"	7'-2"	5'-0"	1.29	d1 E	#4	1	17'-4 <sup>3</sup> / <sub>4</sub> "	12
											d2 E	#4	1	15'-10 <sup>3</sup> / <sub>4</sub> "	11
											d3 E	#4	1	14'-3 <sup>1</sup> / <sub>2</sub> "	10
											d4 E	#4	1	12'-9 <sup>3</sup> / <sub>4</sub> "	9
											d5 E	#4	1	11'-2 <sup>1</sup> / <sub>2</sub> "	7
											d10 E	#4	6	4'-8"	19
	(2) - 8" PIPE OR (1) - 6" PIPE & (1) - 8" PIPE	1'-5"	8"	2'-1"	1'-8"	3'-10"	1'-8"	7'-2"	5'-0"	1.51	d11 E	#4	6	3'-10 <sup>3</sup> / <sub>4</sub> "	16
											d12 E	#4	6	6'-10"	27
											d13 E	#4	2	4'-8"	6
											d1 E	#4	1	18'-4 <sup>3</sup> / <sub>4</sub> "	12
											d2 E	#4	1	16'-10 <sup>3</sup> / <sub>4</sub> "	11
											d3 E	#4	1	15'-3 <sup>1</sup> / <sub>2</sub> "	10
											d4 E	#4	1	13'-9 <sup>3</sup> / <sub>4</sub> "	9
d5 E	#4	1	12'-2 <sup>1</sup> / <sub>2</sub> "	8											
d6 E	#4	1	10'-8"	7											
d10 E	#4	6	5'-4"	21											
d11 E	#4	6	4'-6 <sup>1</sup> / <sub>2</sub> "	18											
d12 E	#4	6	6'-10"	27											
d13 E	#4	2	4'-8"	6											

	PIPE I.D.	DIMENSIONS								PRECAST CONCRETE CU YD	MARK	SIZE	NO	LENGTH	LB		
		A	B	C	N	S	M	L	W								
1 TO 6 SLOPE	(2) - 6" PIPE	1'-5"	6"	1'-11"	1'-8"	3'-10"	1'-8"	7'-7"	1'-8"	10'-11"	5'-0"	2.00	d1 E	#4	1	17'-6"	12
													d2 E	#4	1	16'-7"	11
													d3 E	#4	1	15'-8"	10
													d4 E	#4	1	14'-9"	10
													d5 E	#4	1	13'-10"	9
													d6 E	#4	1	12'-10 <sup>3</sup> / <sub>4</sub> "	9
													d7 E	#4	1	12'-0"	8
													d8 E	#4	1	11'-3 <sup>1</sup> / <sub>4</sub> "	7
													d10 E	#4	6	7'-9 <sup>3</sup> / <sub>4</sub> "	31
													d11 E	#4	6	6'-7 <sup>3</sup> / <sub>4</sub> "	27
													d12 E	#4	6	10'-7 <sup>1</sup> / <sub>4</sub> "	42
													d13 E	#4	2	4'-8"	6
	(2) - 8" PIPE OR (1) - 6" PIPE & (1) - 8" PIPE	1'-5"	8"	2'-1"	1'-8"	3'-10"	1'-8"	7'-7"	1'-8"	10'-11"	5'-0"	2.33	d1 E	#4	1	18'-6"	12
													d2 E	#4	1	17'-7"	12
													d3 E	#4	1	16'-8"	11
													d4 E	#4	1	15'-9"	11
													d5 E	#4	1	14'-10"	10
													d6 E	#4	1	13'-10 <sup>3</sup> / <sub>4</sub> "	9
													d7 E	#4	1	13'-0"	9
													d8 E	#4	1	12'-3 <sup>1</sup> / <sub>4</sub> "	8
													d9 E	#4	1	11'-1 <sup>1</sup> / <sub>4</sub> "	7
													d10 E	#4	6	8'-11"	36
													d11 E	#4	6	7'-9"	31
													d12 E	#4	6	10'-7 <sup>1</sup> / <sub>4</sub> "	42
d13 E	#4	2	4'-8"	6													

**DIMENSIONS AND QUANTITIES FOR DOUBLE SLOPED HEADWALL TYPE III**

	PIPE I.D.	DIMENSIONS								PRECAST CONCRETE CU YD	MARK	SIZE	NO	LENGTH	LB
		A	B	C	N	S	M	L	W						
1 TO 4 SLOPE	(2) - 6" PIPE	1'-5"	6"	1'-11"	1'-8"	5'-1"	1'-8"	8'-5"	5'-0"	1.53	d1 E	#4	1	17'-5 <sup>1</sup> / <sub>4</sub> "	12
											d2 E	#4	1	16'-2 <sup>1</sup> / <sub>4</sub> "	11
											d3 E	#4	1	14'-11"	10
											d4 E	#4	1	13'-8"	9
											d5 E	#4	1	12'-4 <sup>3</sup> / <sub>4</sub> "	8
											d6 E	#4	1	11'-1 <sup>3</sup> / <sub>4</sub> "	7
	(2) - 8" PIPE OR (1) - 6" PIPE & (1) - 8" PIPE	1'-5"	8"	2'-1"	1'-8"	5'-1"	1'-8"	8'-5"	5'-0"	1.79	d10 E	#4	6	5'-8 <sup>3</sup> / <sub>4</sub> "	23
											d11 E	#4	6	4'-9 <sup>3</sup> / <sub>4</sub> "	19
											d12 E	#4	6	8'-1 <sup>1</sup> / <sub>4</sub> "	32
											d13 E	#4	2	4'-8"	6
											d1 E	#4	1	18'-5 <sup>1</sup> / <sub>4</sub> "	12
											d2 E	#4	1	17'-2 <sup>1</sup> / <sub>4</sub> "	11
											d3 E	#4	1	15'-11"	11
d4 E	#4	1	14'-8"	10											
d5 E	#4	1	13'-4 <sup>3</sup> / <sub>4</sub> "	9											
d6 E	#4	1	12'-1 <sup>3</sup> / <sub>4</sub> "	8											
d7 E	#4	1	10'-10 <sup>3</sup> / <sub>4</sub> "	7											
d10 E	#4	6	6'-8 <sup>1</sup> / <sub>4</sub> "	26											
d11 E	#4	6	5'-7 <sup>1</sup> / <sub>4</sub> "	22											
d12 E	#4	6	8'-1 <sup>1</sup> / <sub>4</sub> "	32											
d13 E	#4	2	4'-8"	6											

APPROVED BY:  DATE: 03/01/2022  
 CHIEF ENGINEERING OFFICER



**SLOPED HEADWALLS TYPE III DETAILS**

VERSION: 2022-03      STANDARD: B10-13      SHEET: 3 OF 3

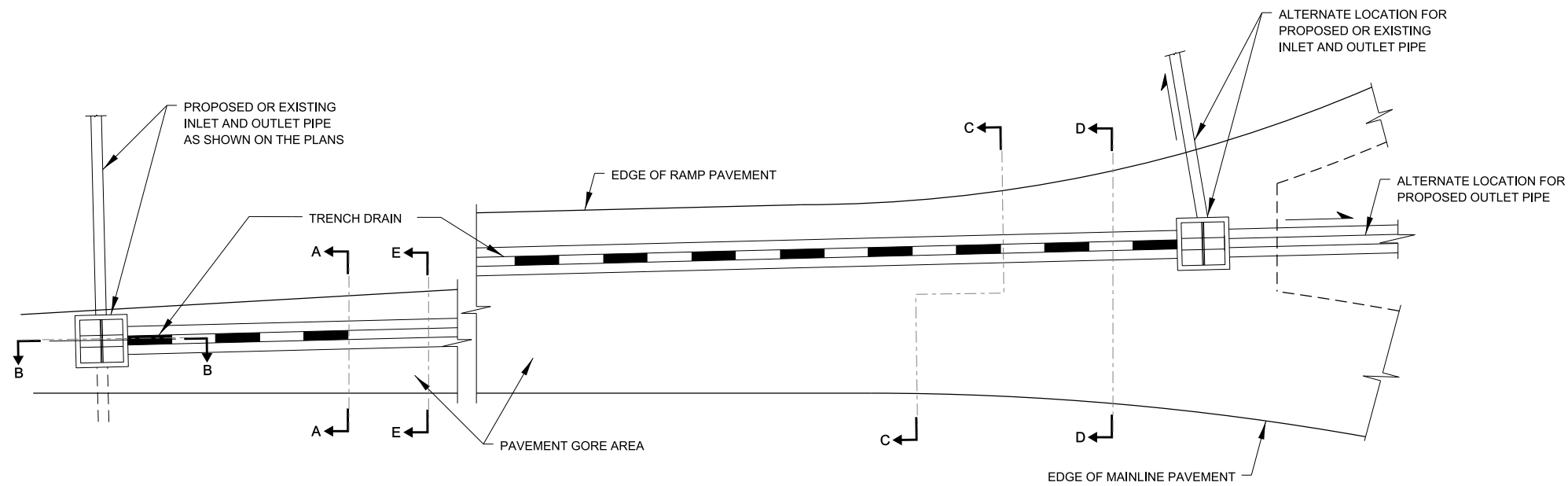

PLAN

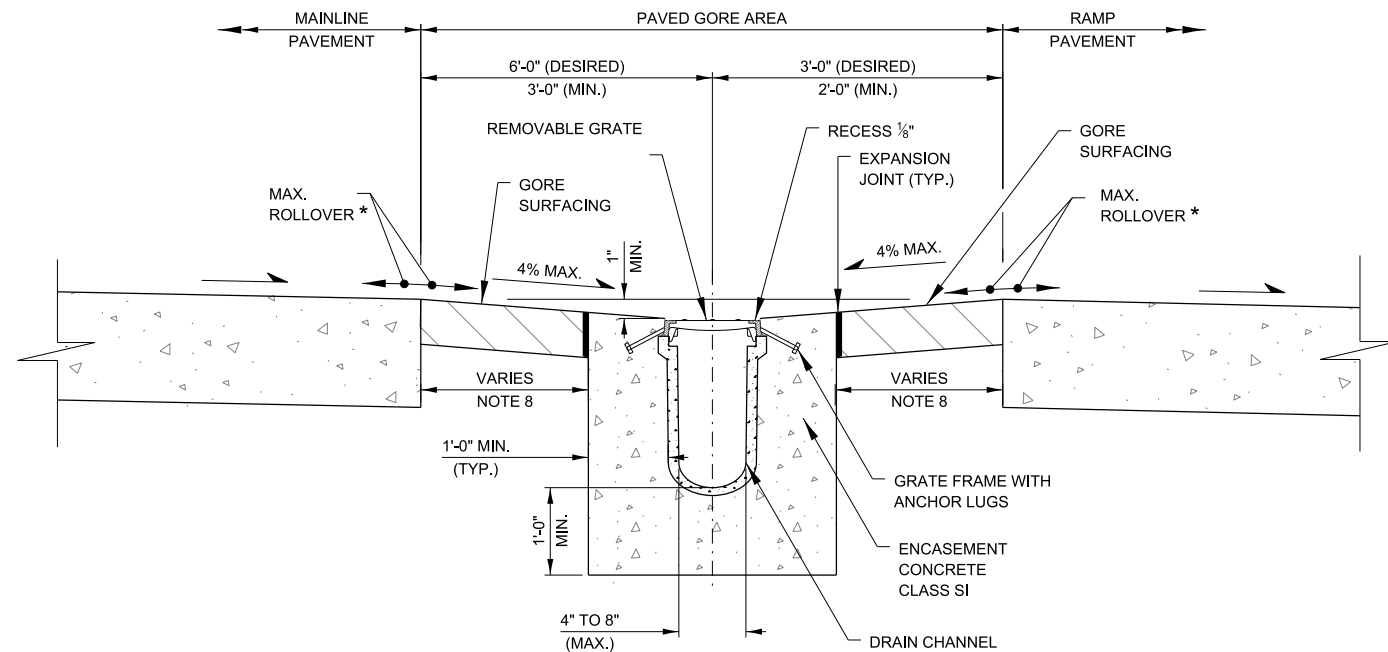

SECTION A-A  
TRENCH DRAIN INSTALLATION

NOTES:

1. OUTLET PIPES AND PREFORMED CHANNEL INVERTS SHALL BE SLOPED AT 0.6% OR STEEPER TOWARD OUTLET REGARDLESS OF THE SURFACE SLOPE.
2. TRENCH DRAIN MAY BE STUBBED DIRECTLY INTO DRAINAGE STRUCTURES OR OUTLET PIPES MAY BE USED TO CONNECT TRENCH DRAIN TO DRAINAGE STRUCTURES.
3. TRENCH EXCAVATION MUST ALLOW FOR A MINIMUM OF 12 INCHES OF CONCRETE TO BE PLACED UNDER AND ALONGSIDE THE TRENCH DRAIN CHANNEL SYSTEM.
4. THE FINISHED LEVEL OF CONCRETE MUST BE APPROXIMATELY 1/8" ABOVE THE TOP OF THE DRAIN CHANNEL.
5. TRENCH DRAINS SHALL BE IN ACCORDANCE WITH THE MANUFACTURERS DETAILS AND SPECIFICATIONS.
6. PROVIDE 1" EXPANSION JOINT WITH PREFORMED JOINT FILLER BETWEEN PAVED SHOULDER AND TRENCH DRAIN ENCASEMENT.
7. ALL SLOPES ARE EXPRESSED AS UNITS OF VERTICAL DISPLACEMENT TO UNITS OF HORIZONTAL PLACEMENT (V:H).
8. WHEN THE CONCRETE ENCASEMENT FOR TRENCH DRAIN IS WITHIN 6' OF THE PAVEMENT, REPLACE THE GORE SURFACING WITH CLASS SI CONCRETE 9" DEPTH; PAY ITEM: PORTLAND CEMENT CONCRETE SHOULDERS (JOINTED) 9".

\* MAXIMUM ROLLOVER AND \*\*MAXIMUM SLOPE FROM EDGE OF SHOULDER VARIES FROM THE PHYSICAL NOSE TO THE GORE NOSE ACCORDING TO THE FOLLOWING:

FOR EXIT RAMPS: \* 5% MAX. ROLLOVER AND \*\* 9% MAX. SLOPE FROM EDGE OF SHOULDER

FOR ENTRANCE RAMPS: \* 7% MAX. ROLLOVER AND \*\* 10% MAX. SLOPE FROM EDGE OF SHOULDER



REVISIONS	
DATE	DESCRIPTION
03-01-2018	UPDATED MAX. ROLLOVER REQS
	REVISION SECTION E-E HATCHING
03-31-2016	REVISED PIPING BEND
03-11-2015	REVISED ROLLOVER, ADDED CATCH
	BASIN, TYPE B
03-31-2014	REVISED NOTES

TRENCH DRAIN DETAIL

VERSION: 2018-03 STANDARD: B12-07 SHEET: 1 OF 2

APPROVED BY:

DATE:

*Paul Kovacs*  
CHIEF ENGINEERING OFFICER

03/01/2018

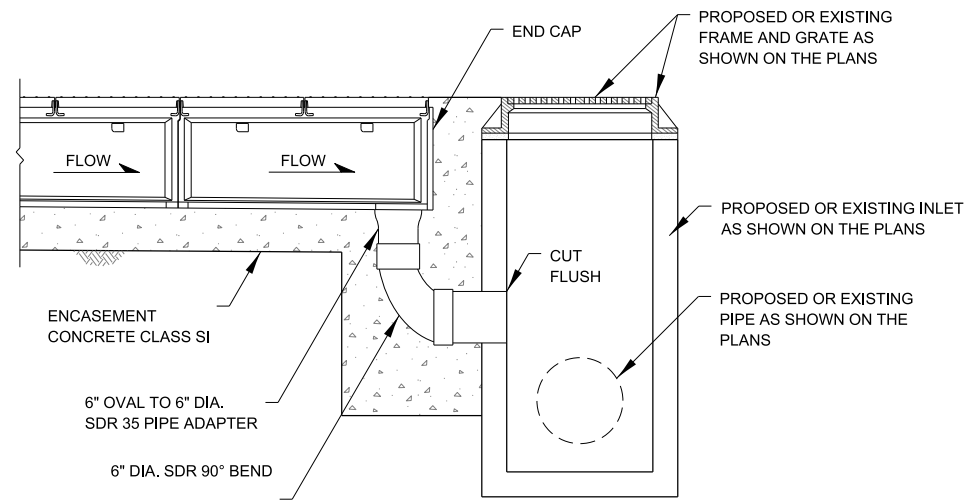

SECTION B-B  
PIPE OUTLET TO DRAINAGE STRUCTURE

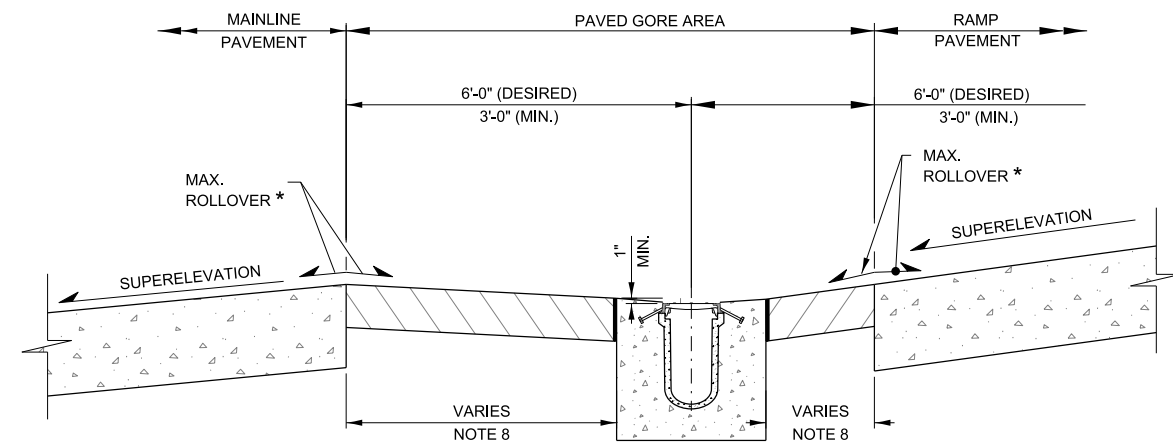

SECTION E-E  
RAMP ON OUTSIDE OF  
SUPERELEVATED MAINLINE SECTION

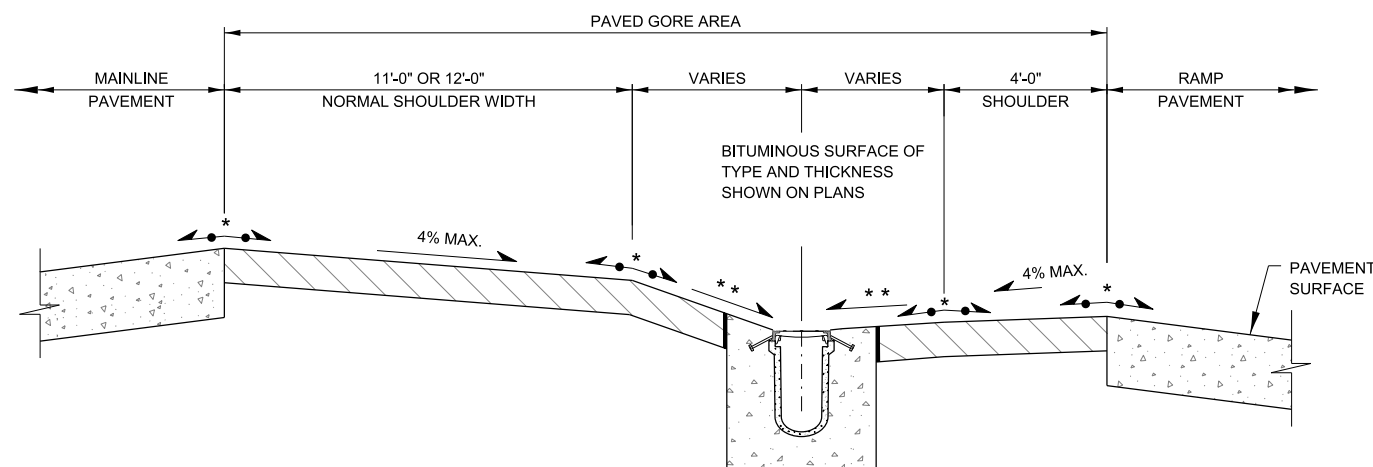

SECTION D-D

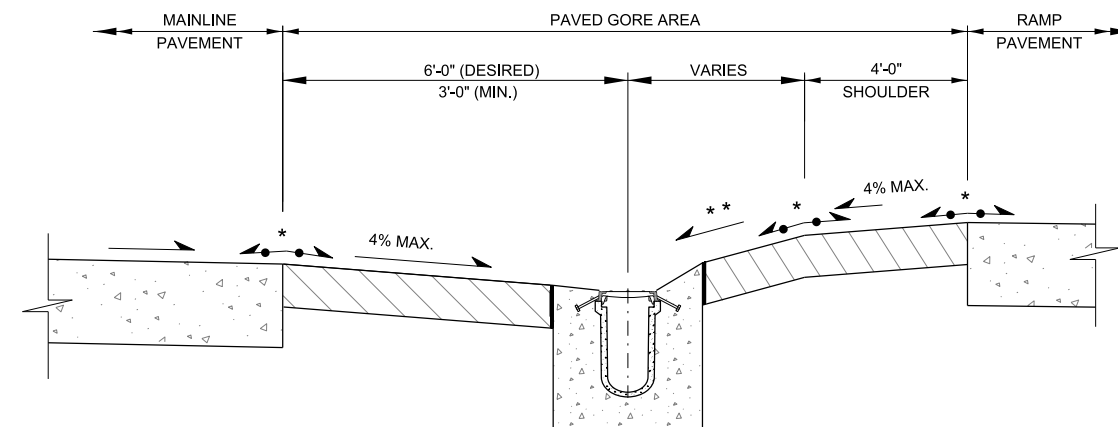

SECTION C-C

NOTE:  
SEE SHEET 1 OF THIS SERIES FOR NOTES.

APPROVED BY: *Paul Kovacs*  
CHIEF ENGINEERING OFFICER  
DATE: 03/01/2018

**Illinois Tollway**

TRENCH DRAIN DETAIL

VERSION: 2018-03	STANDARD: B12-07	SHEET: 2 OF 2
---------------------	---------------------	------------------

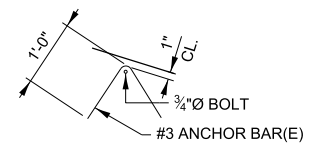

**ANCHOR BARS**  
CONTRACTOR SHALL PROVIDE 2-#3 ANCHOR BARS(E) PER SIDEWALL BOLT.

**DETAIL B**

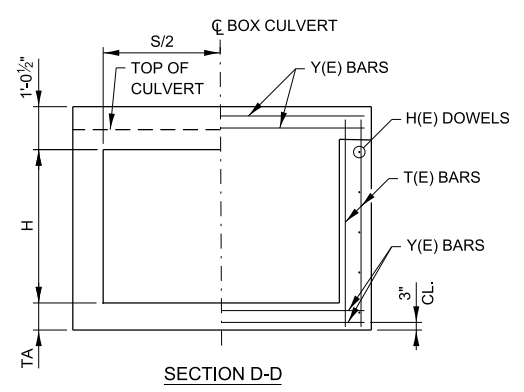

**SECTION D-D**

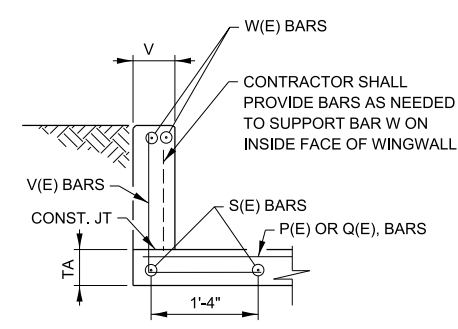

**SECTION A-A**

**NOTE:**  
J & H, DOWEL BARS NOT REQUIRED WITH EXISTING BOX CULVERTS PROVIDING THE REINFORCING FROM THE EXISTING BOX IS EXTENDED INTO THE NEW CONCRETE A MINIMUM OF 1'-3".

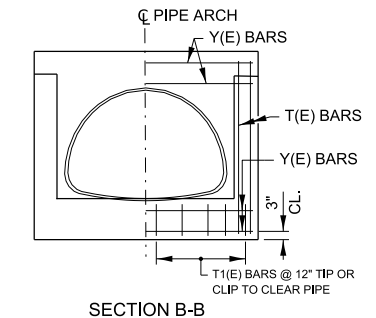

**SECTION B-B**

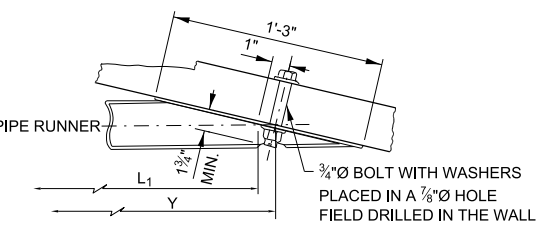

**SECTION AT WING**

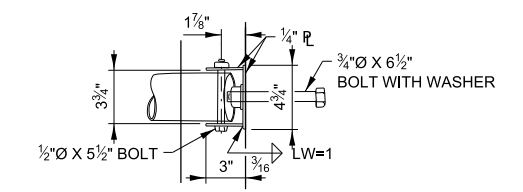

**PLAN AT HEADWALL**

**NOTE:**  
A 3/4" X 9 1/2" BOLT WITH ADDITIONAL R WASHER PLACED IN A 1/8" HOLE DRILLED THROUGH THE HEADWALL OR A 3/4" X 8" THREADED ROD EPOXY GROUTED IN A 1/8" HOLE WITH A MINIMUM EMBEDMENT OF 6 5/8" MAY BE USED IN LIEU OF CAST-IN-PLACE BOLT SHOWN.

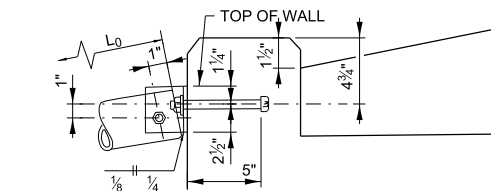

**ELEVATION AT HEADWALL**

**NOTE:**  
V, P1 AND U BARS ARE TO BE FIELD CUT PER CUTTING DIAGRAM. PLACE ONE-HALF THE BARS IN OR NEAR EACH WINGWALL BEGINNING WITH THE SHORTEST V BARS AND P1 BARS AT THE TOEWALL END AND LONGEST U BARS AT THE BOTTOM OF THE WALL.

**NOTE:**  
Q(E) BARS ARE TO BE FIELD CUT PER CUTTING DIAGRAM. PLACE BARS WITH DIMENSIONS C4-C5 BEGINNING AT HEADWALL AND BARS WITH DIMENSIONS C3-C6 BEGINNING AT THE TOEWALL END.

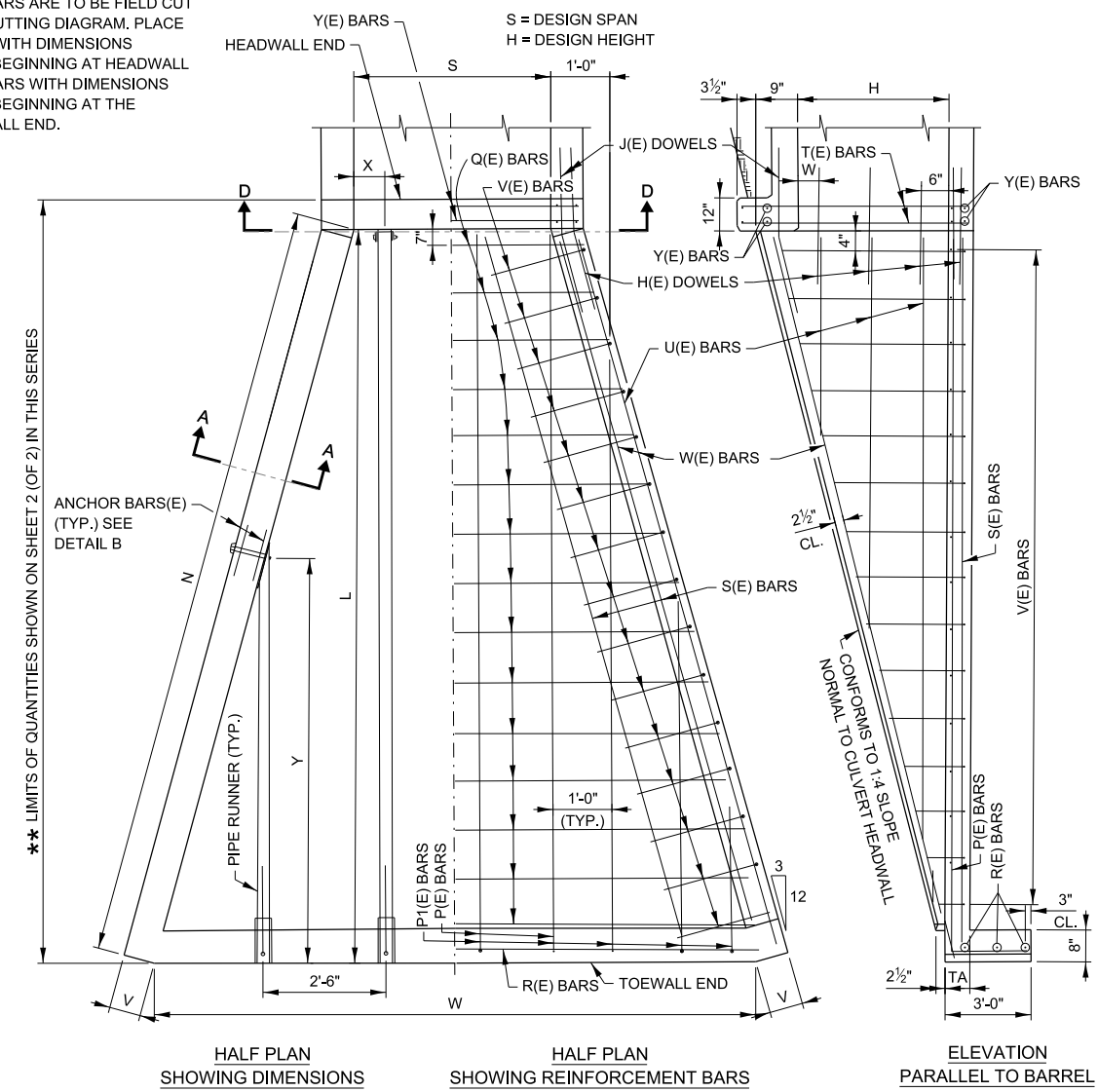

**BOX CULVERT DETAILS**

\*\* DOWEL BARS EXTENDING INTO THE CONCRETE BOX CULVERT ARE INCLUDED IN THE QUANTITIES

\*\* LIMITS OF QUANTITIES SHOWN ON SHEET 2 (OF 2) IN THIS SERIES

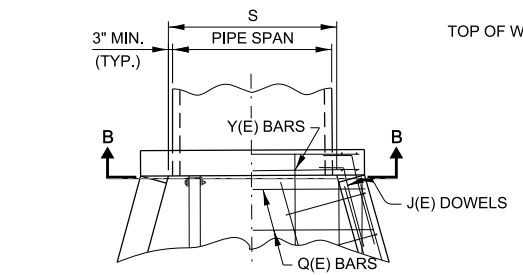

**HALF PLAN SHOWING DIMENSIONS HALF PLAN SHOWING REINFORCEMENT BARS**

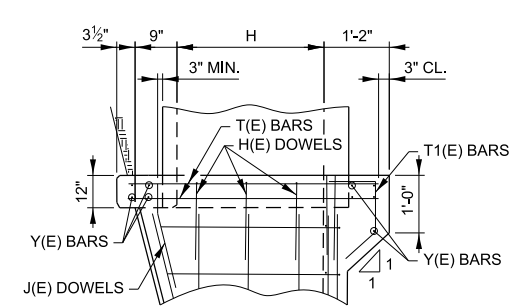

**ELEVATION PIPE ARCH DETAILS**

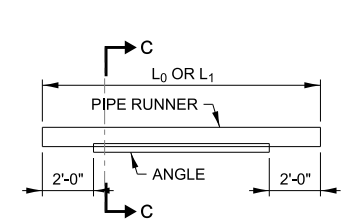

**DETAIL A PIPE RUNNER DETAILS**

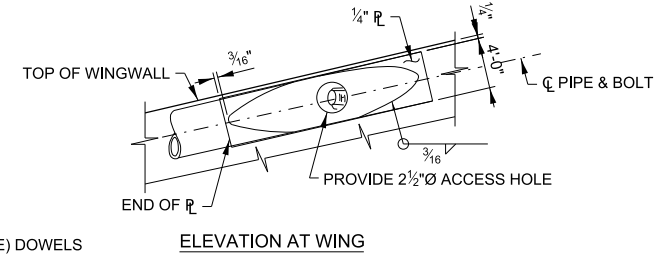

**ELEVATION AT WING**

**NOTE:**  
PIPE O.D. IS THE PIPE RUNNER OUTSIDE DIAMETER.

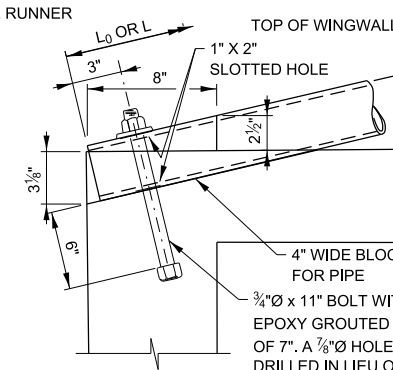

**SECTION THRU TOEWALL**

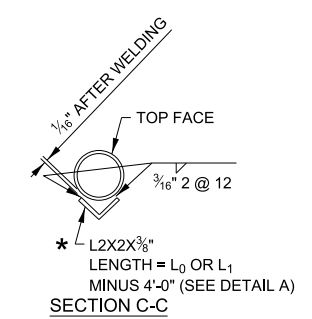

**NOTE:**  
WHERE L0 OR L1 EXCEEDS THE FOLLOWING LENGTH, THE PIPE RUNNER SHALL BE STRENGTHENED OVER THE MIDSPAN AS SHOWN.

PIPE	LENGTH
3"Ø, SCH. 40	12'-8"

**GENERAL NOTES:**

- ALL CONCRETE SHALL BE CLASS SI.
- ALL EXPOSED CONCRETE EDGES SHALL HAVE A 3/4" x 45° CHAMFER. CHAMFER ON VERTICAL EDGES SHALL BE CONTINUED A MINIMUM OF ONE FOOT BELOW FINISHED GROUND LEVEL. COVER FROM THE FACE OF CONCRETE TO THE FACE OF REINFORCEMENT BARS SHALL BE 2", UNLESS OTHERWISE SHOWN.
- CONCRETE QUANTITIES SHOWN ON SHEET 2 (OF 2) IN THIS SERIES ARE FOR REINFORCED CONCRETE BOX CULVERT SECTIONS AND ADDITIONAL CONCRETE REQUIRED IN HEADWALLS FOR PIPE OR ARCH CULVERT SECTIONS SHALL BE ADDED TO THESE QUANTITIES.
- THIS STANDARD MAY BE USED FOR CULVERTS WITH SKEW OF 0° ± 7.5°. AS SHOWN PER CULVERT SKEW ORIENTATION ON THIS SHEET.
- DESIGN: SAFETY PIPE RUNNERS ARE DESIGNED FOR A TRANSVERSING LOAD OF 1,800 POUNDS AT YIELD AS RECOMMENDED BY RESEARCH REPORT 280-1, SAFETY TREATMENT OF ROADSIDE CROSS DRAINAGE STRUCTURES, TEXAS TRANSPORTATION INSTITUTE, MARCH 1981.
- ALL SLOPES ARE EXPRESSED AS UNITS OF VERTICAL DISPLACEMENT TO UNITS OF HORIZONTAL DISPLACEMENT (V:H).
- FOR EROSION PROTECTION SEE STANDARD B19.
- ALL REINFORCEMENT BARS SHOWN SHALL BE EPOXY COATED (E).

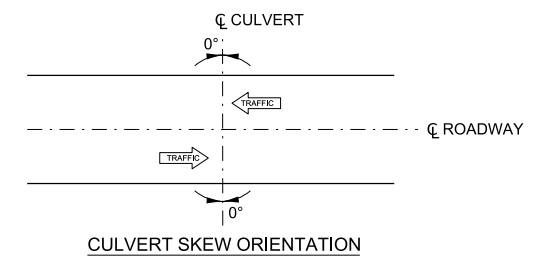

**CULVERT SKEW ORIENTATION**

APPROVED BY: *Paul Kovacs* CHIEF ENGINEERING OFFICER  
DATE: 03/01/2022

REVISIONS	
DATE	DESCRIPTION
03-01-2022	REVISED HEADWALL THICKNESS AND REBAR TABLE
03-11-2015	REVISED NOTES
03-31-2014	TABLE QUANTITIES REVISED
02-07-2012	TABLE QUANTITIES REVISED

**Illinois Tollway**

**END TREATMENT WITH PIPE RUNNERS, FOR SINGLE CULVERTS**  
0° SKEW, 1:4 SLOPE, H ≤ 4'

VERSION: 2022-03	STANDARD: B13-06	SHEET: 1 OF 2
------------------	------------------	---------------

CULVERT SIZE	TABLE OF DIMENSIONS							TOTAL QUANTITIES ONE END			PIPE RUNNERS FOR ONE END - SIZE 3" O.D.			
								CONC.	REINF. BARS	PIPE RUNNER	HEADWALL PIPE		WINGWALL PIPE	
	S x H	L	N	V	W	TA	X	Y	CU. YD.	POUND	FT.	NO.	L <sub>0</sub>	NO.
3 x 2	10'-10"	11'-2"	7"	8'-5"	6"	0'-3"	-	3.2	346	22.16	2	11'-1"	0	-
3 x 3	14'-10"	15'-3 1/2"	7"	10'-5"	6"	1'-6"	10'-10"	5.2	489	37.50	1	15'-2"	2	11'-2"
4 x 2	10'-10"	11'-2"	7"	9'-5"	6"	0'-9"	-	3.4	372	22.16	2	11'-1"	0	-
4 x 3	14'-10"	15'-3 1/2"	7"	11'-5"	6"	2'-0"	12'-10"	6.5	521	41.50	1	15'-2"	2	13'-2"
4 x 4	18'-10"	19'-5"	7"	13'-5"	6"	0'-9"	11'-10"	8.1	727	63.00	2	19'-4"	2	12'-2"
5 x 2	10'-10"	11'-2"	7"	10'-5"	6"	1'-3"	9'-10"	3.7	397	34.16	2	11'-1"	2	6'-0"
5 x 3	14'-10"	15'-3 1/2"	7"	12'-5"	6"	1'-3"	9'-10"	5.9	554	50.50	2	15'-2"	2	10'-1"
5 x 4	18'-10"	19'-5"	7"	14'-5"	6"	1'-3"	13'-10"	8.5	765	67.17	2	19'-4"	2	14'-3"
6 x 3	14'-10"	15'-3 1/2"	7"	13'-5"	6"	1'-9"	11'-10"	6.2	583	54.67	2	15'-2"	2	12'-2"
6 x 4	18'-10"	19'-5"	7"	15'-5"	6"	0'-6"	10'-10"	8.9	800	80.33	3	19'-4"	2	11'-2"
7 x 3	14'-10"	15'-3 1/2"	7"	14'-5"	6 1/2"	2'-3"	13'-10"	6.5	614	58.83	2	15'-2"	2	14'-3"
7 x 4	18'-10"	19'-5"	7"	16'-5"	6 1/2"	1'-0"	12'-10"	9.3	835	84.33	3	19'-4"	2	13'-2"
8 x 4	18'-10"	19'-5"	7"	17'-5"	7"	0'-3"	9'-10"	9.7	871	97.50	4	19'-4"	2	10'-1"

**PIPE ARCH AND ELLIPTICAL PIPE CULVERTS**

FOR PIPE ARCH OR ELLIPTICAL PIPE CULVERTS SELECT APPROPRIATE "S" & "H" FROM SIZES SHOWN. ADD THE FOLLOWING ADDITIONAL BARS:

- (a) 1 ADDITIONAL Y(E) BAR
- (b) #4 - T1(E) BARS @ APPROX. 12" CTS. (NO. = S + 2)

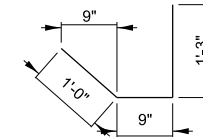

**T1(E) BARS**

THE WEIGHT OF THE ADDITIONAL BARS AND THE ADDITIONAL QUANTITY OF CONCRETE IN THE HEADWALL SHALL BE ADDED TO THE QUANTITIES SHOWN.

CULVERT SIZE	TABLE OF REINFORCING STEEL FOR ONE END																														
	H(E) DOWEL #4 @ 12"		J(E) DOWEL #6		P(E) BARS #4 @ 12"		P1(E) BARS #4 @ 12"			Q(E) BARS #4 @ 12"						R(E) BARS 3-#4	S(E) BARS 4-#4	U(E) BARS #4 @ 12"			V(E) BARS #4 @ 10.5"			4 W(E) BARS		Y(E) BARS 8-#5	T(E) BARS 8-#5 BOX CULVERT	T(E) BARS 8-#5 PIPE ARCH			
	NO.	LENGTH.	NO.	LENGTH.	NO.	LENGTH.	NO.	C <sub>1</sub>	C <sub>2</sub>	LENGTH.	NO.	C <sub>3</sub>	C <sub>4</sub>	C <sub>5</sub>	C <sub>6</sub>	LENGTH.	LENGTH.	LENGTH.	NO.	C <sub>7</sub>	C <sub>8</sub>	LENGTH.	NO.	C <sub>9</sub>	C <sub>10</sub>	LENGTH.	SIZE	LENGTH.	LENGTH.	LENGTH.	LENGTH.
3 x 2	6	2'-6"	4	4'-0"	4	13'-1"	2	8'-4"	4'-4"	17'-10"	5	8'-8"	4'-2"	6'-2"	6'-8"	12'-10"	8'-9"	10'-10"	2	8'-7"	4'-5"	13'-0"	11	2'-9"	6"	6'-3"	#5	10'-4"	3'-8"	3'-2"	3'-8"
3 x 3	8	2'-6"	4	4'-0"	4	17'-1"	3	12'-4"	4'-4"	21'-10"	7	10'-8"	4'-2"	7'-2"	7'-8"	14'-10"	10'-9"	15'-0"	3	12'-8"	4'-5"	17'-1"	16	3'-9"	6"	7'-3"	#5	14'-6"	3'-8"	4'-2"	4'-8"
4 x 2	6	2'-6"	4	4'-0"	5	13'-1"	2	8'-4"	4'-4"	17'-10"	5	9'-8"	5'-2"	7'-2"	7'-8"	14'-10"	9'-9"	15'-0"	2	8'-7"	4'-5"	13'-0"	11	2'-9"	6"	6'-3"	#5	10'-4"	4'-8"	3'-2"	3'-8"
4 x 3	8	2'-6"	4	4'-0"	5	17'-1"	3	12'-4"	4'-4"	21'-10"	7	11'-8"	5'-2"	8'-2"	8'-8"	16'-10"	11'-9"	15'-0"	3	12'-8"	4'-5"	17'-1"	16	3'-9"	6"	7'-3"	#5	14'-6"	4'-8"	4'-2"	4'-8"
4 x 4	10	2'-6"	4	4'-0"	5	21'-1"	4	16'-4"	4'-4"	25'-10"	9	13'-8"	5'-2"	9'-2"	9'-8"	18'-10"	13'-9"	19'-1"	4	16'-9"	4'-5"	21'-2"	21	4'-9"	6"	8'-3"	#6	18'-7"	4'-8"	5'-2"	5'-8"
5 x 2	6	2'-6"	4	4'-0"	6	13'-1"	2	8'-4"	4'-4"	17'-10"	5	10'-8"	6'-2"	8'-2"	8'-8"	16'-10"	10'-9"	10'-10"	2	8'-7"	4'-5"	13'-0"	11	2'-9"	6"	6'-3"	#5	10'-4"	5'-8"	3'-2"	3'-8"
5 x 3	8	2'-6"	4	4'-0"	6	17'-1"	3	12'-4"	4'-4"	21'-10"	7	12'-8"	6'-2"	9'-2"	9'-8"	18'-10"	12'-9"	15'-0"	3	12'-8"	4'-5"	17'-1"	16	3'-9"	6"	7'-3"	#5	14'-6"	5'-8"	4'-2"	4'-8"
5 x 4	10	2'-6"	4	4'-0"	6	21'-1"	4	16'-4"	4'-4"	25'-10"	9	14'-8"	6'-2"	10'-2"	10'-8"	20'-10"	14'-9"	19'-1"	4	16'-9"	4'-5"	21'-2"	21	4'-9"	6"	8'-3"	#6	18'-7"	5'-8"	5'-2"	5'-8"
6 x 3	8	2'-6"	4	4'-0"	7	17'-1"	3	12'-4"	4'-4"	21'-10"	7	13'-8"	7'-2"	10'-2"	10'-8"	20'-10"	13'-9"	15'-0"	3	12'-8"	4'-5"	17'-1"	16	3'-9"	6"	7'-3"	#5	14'-6"	6'-8"	4'-2"	4'-8"
6 x 4	10	2'-6"	4	4'-0"	7	21'-1"	4	16'-4"	4'-4"	25'-10"	9	15'-8"	7'-2"	11'-2"	11'-8"	22'-10"	15'-9"	19'-1"	4	16'-9"	4'-5"	21'-2"	21	4'-9"	6"	8'-3"	#6	18'-7"	6'-8"	5'-2"	5'-8"
7 x 3	8	2'-6"	4	4'-0"	8	17'-1"	3	12'-4"	4'-4"	21'-10"	7	14'-8"	8'-2"	11'-2"	11'-8"	22'-10"	14'-9"	15'-0"	3	12'-8"	4'-5"	17'-1"	16	3'-9"	6"	7'-3"	#5	14'-6"	7'-8"	4'-2"	4'-8"
7 x 4	10	2'-6"	4	4'-0"	8	21'-1"	4	16'-4"	4'-4"	25'-10"	9	16'-8"	8'-2"	12'-2"	12'-8"	24'-10"	16'-9"	19'-1"	4	16'-9"	4'-5"	21'-2"	21	4'-9"	6"	8'-3"	#6	18'-7"	7'-8"	5'-2"	5'-8"
8 x 4	10	2'-6"	4	4'-0"	9	21'-1"	4	16'-4"	4'-4"	25'-10"	9	17'-8"	9'-2"	13'-2"	13'-8"	26'-10"	17'-9"	19'-1"	4	16'-9"	4'-5"	21'-2"	21	4'-9"	6"	8'-3"	#6	18'-7"	8'-8"	5'-3"	5'-8"

**NOTE:**  
REINFORCEMENT BARS BENDING DIMENSIONS ARE OUT TO OUT.

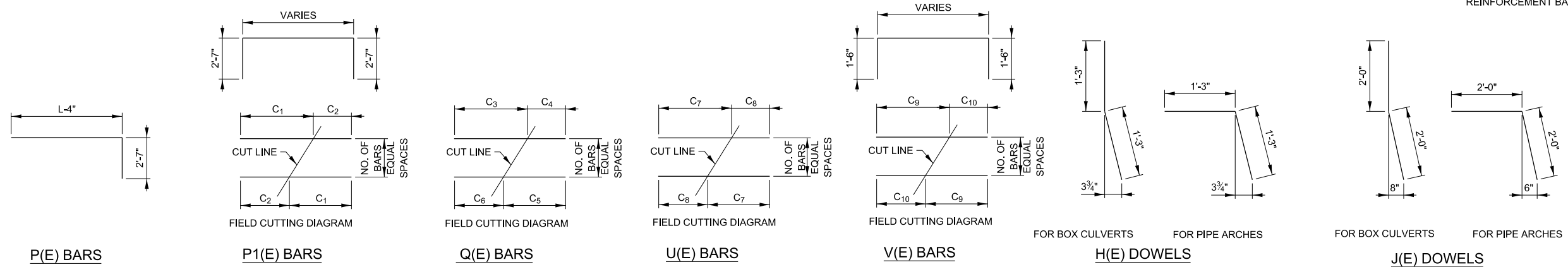

APPROVED BY: *Paul Kovacs*  
CHIEF ENGINEERING OFFICER  
DATE: 03/01/2022

**Illinois Tollway**

**END TREATMENT WITH PIPE RUNNERS, FOR SINGLE CULVERTS**  
0° SKEW, 1:4 SLOPE, H ≤ 4'

VERSION: 2022-03      STANDARD: B13-06      SHEET: 2 OF 2

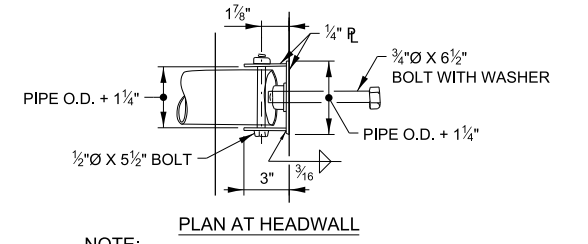
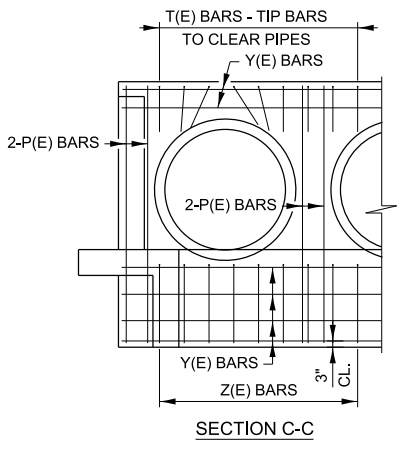
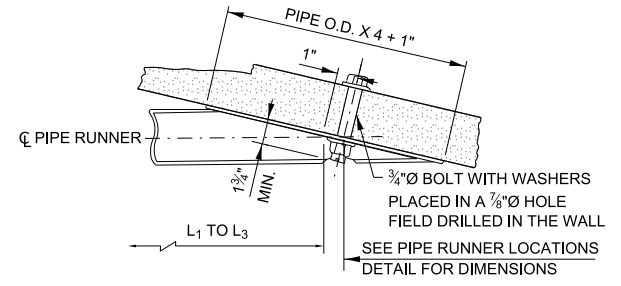
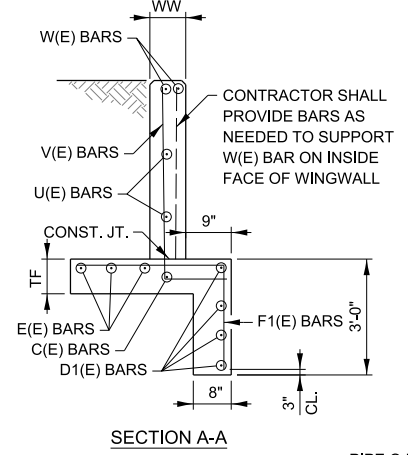
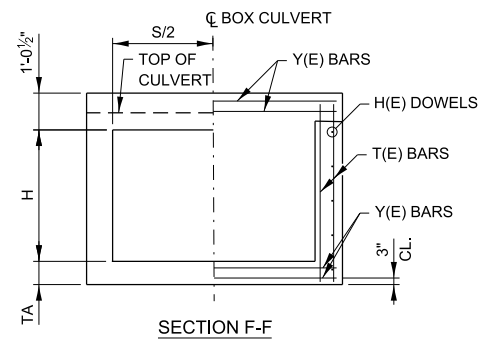
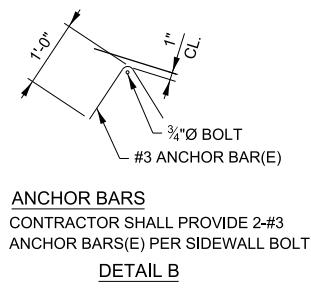

**NOTE:**  
F & V BAR TO BE FIELD CUT PER CUTTING DIAGRAM. PLACE BARS WITH DIMENSIONS C2, C6 BEGINNING AT HEADWALL & BARS WITH DIMENSIONS C1, C5 BEGINNING AT THE TOEWALL END.

**NOTE:**  
J & H, DOWEL BARS NOT REQUIRED WITH EXISTING BOX CULVERTS PROVIDING THE REINFORCING FROM THE EXISTING BOX IS EXTENDED INTO THE NEW CONCRETE A MINIMUM OF 1'-3".

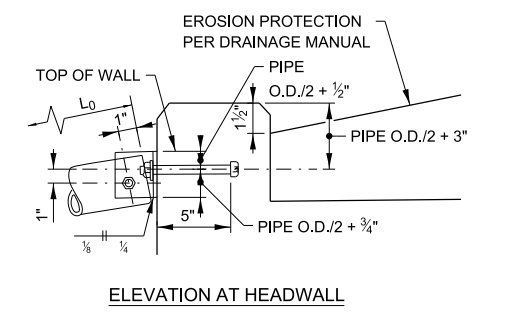
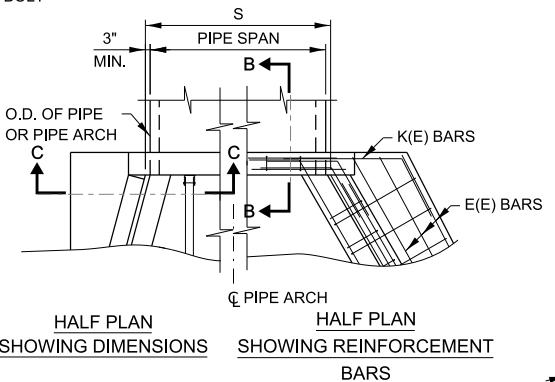
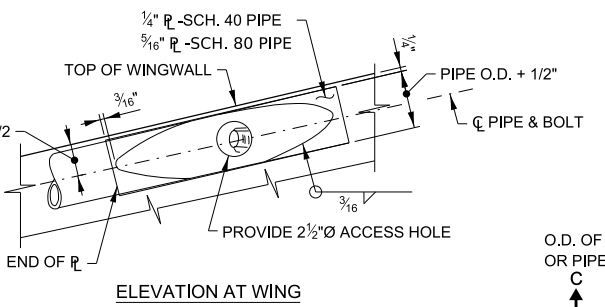

**NOTE:**  
PIPE O.D. IS THE PIPE RUNNER OUTSIDE DIAMETER.

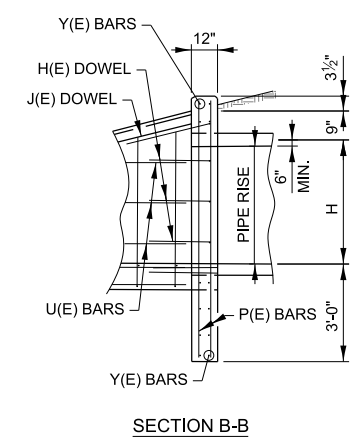
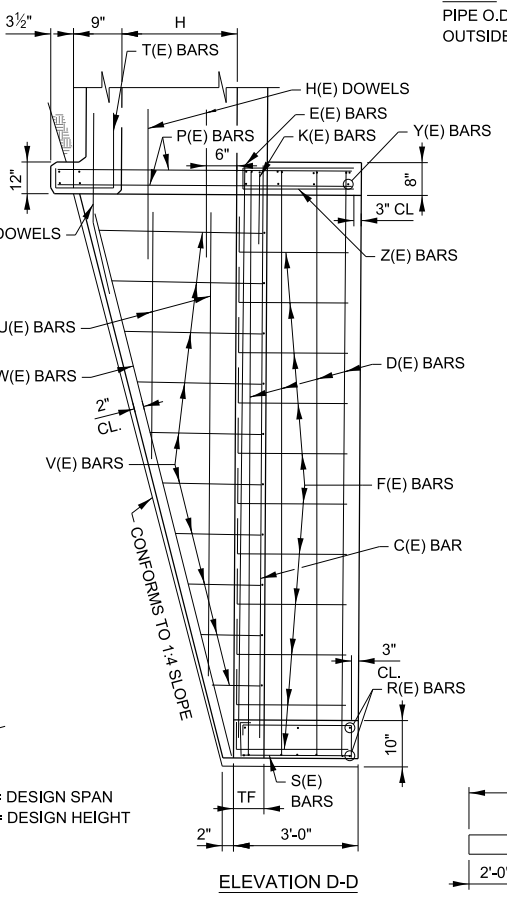
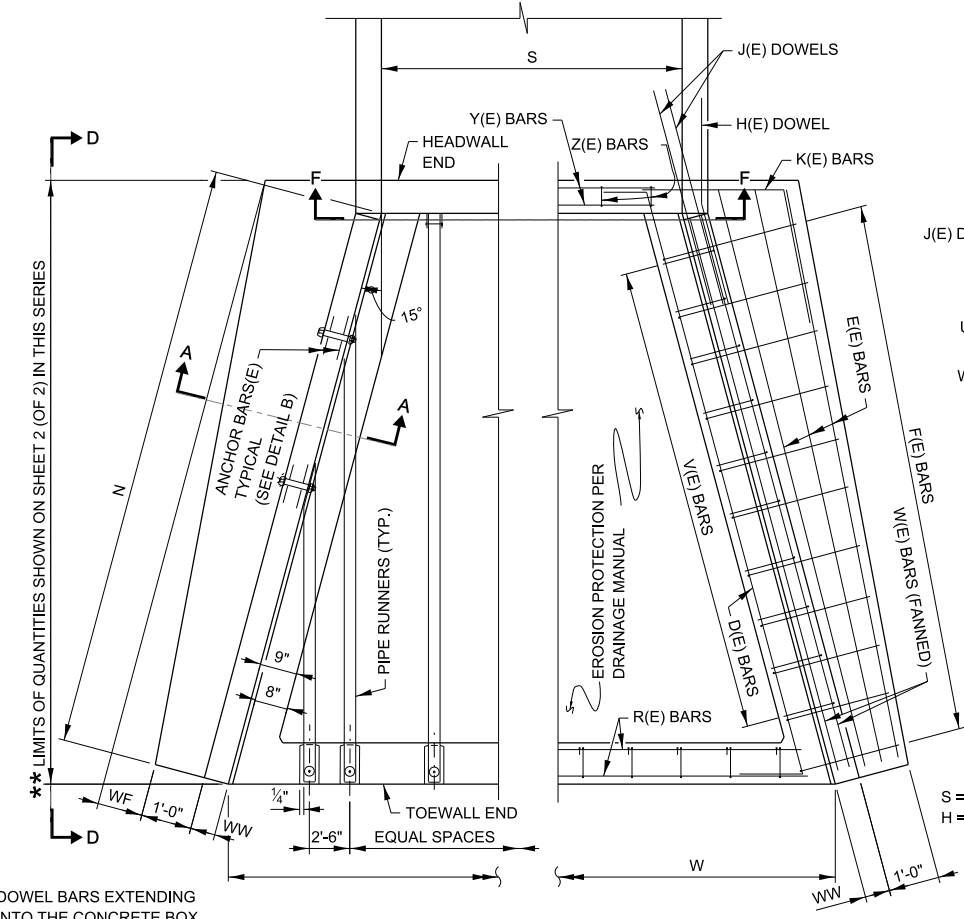

**FOR PIPE AND PIPE-ARCH CULVERTS**

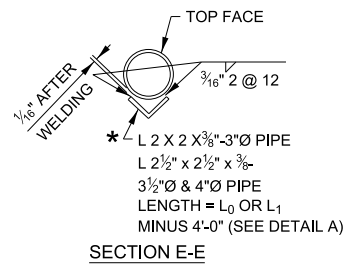
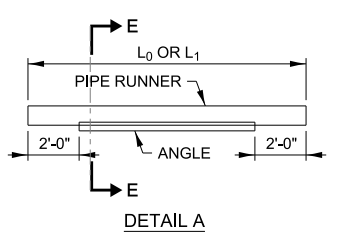

**\* NOTE:**  
WHERE L<sub>0</sub> OR L<sub>1</sub> EXCEEDS THE FOLLOWING LENGTH, THE PIPE RUNNER SHALL BE STRENGTHENED OVER THE MIDSPAN AS SHOWN.

PIPE	LENGTH
3"Ø, SCH. 40	12'-8"
3"Ø, SCH. 40	17'-3"
3"Ø, SCH. 80	22'-1"
4"Ø, SCH. 40	22'-6"
4"Ø, SCH. 80	29'-4"

- GENERAL NOTES:**
- ALL CONCRETE SHALL BE CLASS SI.
  - ALL EXPOSED CONCRETE EDGES SHALL HAVE A 3/4" x 45° CHAMFER. CHAMFER ON VERTICAL EDGES SHALL BE CONTINUED A MINIMUM OF ONE FOOT BELOW FINISHED GROUND LEVEL. COVER FROM THE FACE OF CONCRETE TO THE FACE OF REINFORCEMENT BARS SHALL BE 2", UNLESS OTHERWISE SHOWN.
  - CONCRETE QUANTITIES SHOWN ON SHEET 2 (OF 2) IN THIS SERIES ARE FOR REINFORCED CONCRETE BOX CULVERT SECTIONS AND ADDITIONAL CONCRETE REQUIRED IN HEADWALLS FOR PIPE OR ARCH CULVERT SECTIONS SHALL BE ADDED TO THESE QUANTITIES.
  - THIS STANDARD MAY BE USED FOR CULVERTS WITH SKEW OF 0° ± 7.5°. AS SHOWN PER CULVERT SKEW ORIENTATION ON THIS SHEET.
  - DESIGN: SAFETY PIPE RUNNERS ARE DESIGNED FOR A TRANSVERSING LOAD OF 1,800 POUNDS AT YIELD AS RECOMMENDED BY RESEARCH REPORT 280-1, SAFETY TREATMENT OF ROADSIDE CROSS DRAINAGE STRUCTURES, TEXAS TRANSPORTATION INSTITUTE, MARCH 1981.
  - ALL SLOPES ARE EXPRESSED AS UNITS OF VERTICAL DISPLACEMENT TO UNITS OF HORIZONTAL DISPLACEMENT (V:H).
  - FOR EROSION PROTECTION SEE STANDARD B19.
  - ALL REINFORCEMENT BARS SHALL BE EPOXY COATED (E).

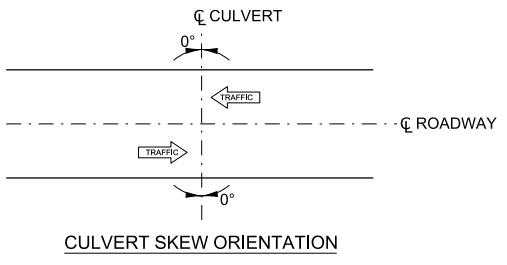

\*\* DOWEL BARS EXTENDING INTO THE CONCRETE BOX CULVERT ARE INCLUDED IN THE QUANTITIES.

APPROVED BY: *Paul Kovacs*  
CHIEF ENGINEERING OFFICER  
DATE: 03/01/2022

REVISIONS	
DATE	DESCRIPTION
03-01-2022	REVISED HEADWALL THICKNESS AND REBAR TABLE
03-11-2015	REVISED NOTES
03-31-2014	TABLE QUANTITIES REVISED
02-07-2012	TABLE QUANTITIES REVISED

**Illinois Tollway**

**END TREATMENT WITH PIPE RUNNERS, FOR SINGLE AND MULTIPLE CULVERTS**  
0° SKEW, 1:4 SLOPE, H ≤ 8'

VERSION: 2022-03  
STANDARD: B14-06  
SHEET: 1 OF 2

TABLE OF DIMENSIONS								TABLE OF REINFORCEMENT BARS FOR ONE END																							
S	H	L	WF	WW	TF	N	C(E) BARS 2 REQ'D.		D(E) BARS 8-#4		E(E) BARS #4 (5)		F(E) BARS			H(E) DOWEL #5 @ 12"		J(E) DOWEL 4-#6		K(E) DOWEL 2-#5		U(E) BARS #4 @ 12"			V(E) BARS #5 @ 6" CTS.				W(E) BARS 4 REQ'D.		
							SIZE	LENGTH	LENGTH	NO.	LENGTH	SIZE	NO.	C <sub>1</sub>	C <sub>2</sub>	LENGTH	NO.	LENGTH	LENGTH	LENGTH	NO.	C <sub>3</sub>	C <sub>4</sub>	LENGTH	NO.	C <sub>5</sub>	C <sub>6</sub>	C <sub>7</sub>	LENGTH	SIZE	LENGTH
9'	3'	14'-4"	3"	7"	7"	14'-10 1/8"	#4	15'-2"	17'-2"	4	16'-8"	#4	15	2'-0"	2'-2"	9'-4"	6	3'-0"	4'-6"	4'-0"	3	12'-8"	4'-5"	17'-1"	28	9"	3'-10"	1'-0"	6'-7"	#5	14'-11"
9'	4'	18'-4"	9"	7"	8"	18'-11 3/4"	#4	19'-4"	21'-4"	4	20'-10"	#4	19	2'-0"	2'-8"	9'-10"	8	3'-0"	4'-6"	4'-6"	4	16'-10"	4'-5"	21'-3"	36	10"	4'-11"	1'-0"	7'-9"	#6	19'-2"
5'	5'	22'-4"	1'-3"	7"	8"	23'-1 1/2"	#4	23'-6"	25'-6"	4	25'-0"	#4	23	2'-0"	3'-2"	10'-4"	10	3'-0"	4'-6"	5'-0"	5	20'-11"	4'-5"	25'-4"	44	10"	5'-11"	1'-0"	8'-9"	#6	23'-5"
6'	6'	26'-4"	1'-9"	7"	8 1/2"	27'-3 3/8"	#4	27'-7"	29'-7"	6	29'-1"	#5	27	2'-0"	3'-8"	10'-10"	12	3'-0"	4'-6"	5'-6"	6	25'-1"	4'-5"	29'-6"	52	10"	6'-11"	1'-0"	9'-9"	#6	27'-8"
7'	7'	30'-4"	2'-3"	7"	9"	31'-4 7/8"	#5	31'-9"	33'-9"	6	33'-3"	#5	31	2'-1"	4'-3"	11'-6"	14	3'-0"	4'-6"	6'-0"	7	29'-2"	4'-5"	33'-7"	60	11"	8'-0"	1'-0"	10'-11"	#6	31'-11"
8'	8'	34'-4"	2'-9"	8 1/2"	9 1/2"	35'-6 1/2"	#5	35'-10"	37'-10"	6	37'-4"	#6	35	2'-2"	4'-10"	12'-2"	16	3'-0"	4'-6"	6'-6"	8	33'-4"	4'-5"	37'-9"	68	11"	9'-0"	1'-1"	12'-1"	#6	36'-2"

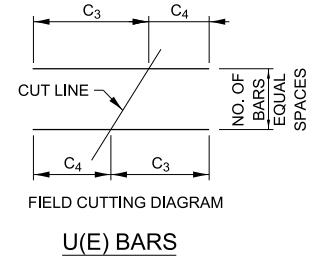

PIPE RUNNERS FOR ONE END								
S	H	SIZE (DIA.)	SCHEDULE	NO. WINGWALL PIPES	L <sub>1</sub>	L <sub>2</sub>	L <sub>3</sub>	LENGTH (FT.)
9'	3'	3"	40	2	9'-11"	-	-	19.84
9'	4'	3"	40	2	14'-0"	-	-	28.00
5'	5'	3 1/2"	40	4	18'-1"	8'-6"	-	53.16
6'	6'	3 1/2"	80	4	22'-3"	12'-7"	-	69.66
7'	7'	4"	40	6	26'-4"	16'-9"	7'-2"	100.50
8'	8'	4"	80	6	30'-6"	20'-10"	11'-7"	125.83

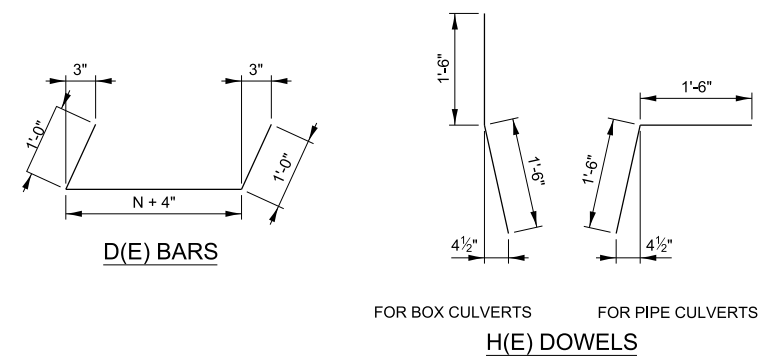

NUMBER OF HDWL PIPE RUNNERS FOR ONE END			
S	No	S	No
10'	4	23'	10
11'	5	24'	10
12'	5	25'	10
13'	6	26'	11
14'	6	27'	11
15'	6	28'	12
16'	7	29'	12
17'	7	30'	12
18'	8	31'	13
19'	8	32'	13
20'	8	33'	14
21'	9	34'	14
22'	9	35'	14

TABLE OF DIMENSIONS			TABLE OF REINFORCEMENT BARS FOR MINIMUM "S"								HEADWALL PIPE RUNNERS FOR MINIMUM "S"				QUANTITIES FOR MIN. "S" (SINGLE PIPE OR CONC. BOX CULVERT)		INCREASE IN QUANTITIES FOR 1' INCREASE IN "S"						
S	H	W (4)	Y(E) BARS 12-#5		Z(E) BARS #4 @ 12"		R(E) BARS 6-#5		S(E) BARS #4 @ 12"		T(E) BARS #4 @ 12"		P(E) BARS 8-#5		SIZE (DIA.)	SCHEDULE	NO.	L <sub>0</sub>	LENGTH (FT.)	CONCRETE CU. YD.	REIN. BARS POUND	CONCRETE CU. YD.	REIN. BARS POUND
			LENGTH	NO.	LENGTH	NO.	LENGTH	NO.	LENGTH	NO.	LENGTH	NO.											
≥9'	3'	16'-8"	9'-10"	9	5'-4"	15'-10"	16	6'-10"	9	3'-0"	6'-8"	3"	40	4	14'-9"	59.00	7.24	863	0.35	13			
≥9'	4'	18'-9"	9'-10"	9	5'-4"	17'-11"	18	6'-10"	9	3'-0"	7'-8"	3"	40	4	18'-10"	75.33	10.44	1078	0.35	13			
≥5'	5'	16'-11"	5'-10"	5	5'-4"	16'-1"	16	6'-10"	5	3'-0"	8'-8"	3 1/2"	40	2	23'-0"	46.00	10.87	1162	0.35	13			
≥6'	6'	20'-1"	6'-10"	6	5'-4"	19'-3"	19	6'-10"	6	3'-0"	9'-8"	3 1/2"	80	3	27'-2"	81.51	14.77	1553	0.35	13			
≥7'	7'	23'-3"	7'-10"	7	5'-4"	22'-5"	22	6'-10"	7	3'-0"	10'-8"	4"	40	3	31'-3"	93.75	19.47	1869	0.35	13			
≥8'	8'	26'-4"	9'-0"	8	5'-4"	25'-6"	25	6'-10"	8	3'-0"	11'-8"	4"	80	4	35'-4"	141.33	25.01	2379	0.35	13			

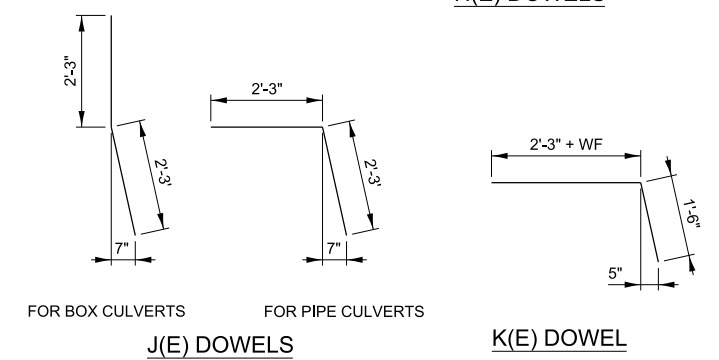

NOTE: REINFORCEMENT BARS BENDING DIMENSIONS ARE OUT TO OUT.

- NOTES FOR TABLE OF DIMENSIONS:
- THE NUMBER OF S, T AND Z BARS SHALL BE INCREASED BY 1 FOR EACH 1 FOOT OF INCREASE IN DIMENSION "S".
  - THE LENGTH OF R AND Y BARS SHALL BE INCREASED BY 1 FOOT FOR EACH 1 FOOT OF INCREASE IN DIMENSION "S".
  - THE NUMBER OF P BARS SHOWN ARE FOR SINGLE SPAN PIPES OR BOX CULVERTS. THIS NUMBER SHALL BE INCREASED BY 4 FOR EACH MULTIPLE OF PIPE OR BOX ADDED.
  - THIS DIMENSION SHALL BE INCREASED BY 1 FOOT FOR EACH 1 FOOT INCREASE IN DIMENSION "S".
  - THE LENGTH OF THIS BAR INCLUDES ONE 1'-6" MINIMUM LAP.

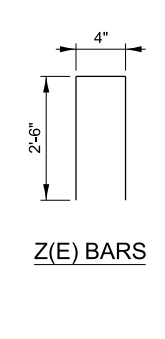
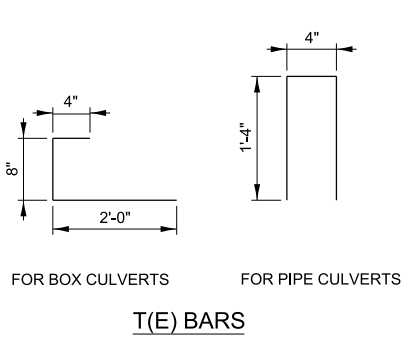
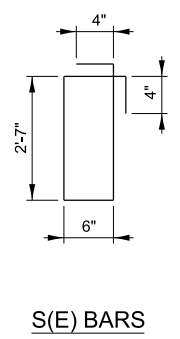
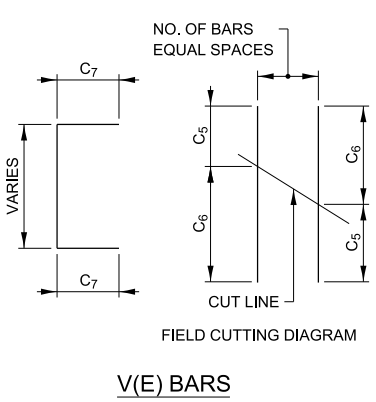
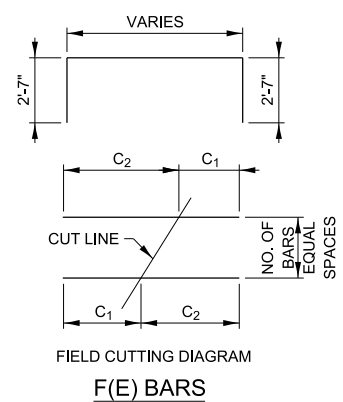

APPROVED BY: *Paul Kovacs*  
CHIEF ENGINEERING OFFICER  
DATE: 03/01/2022

END TREATMENT WITH PIPE RUNNERS, FOR SINGLE AND MULTIPLE CULVERTS  
0° SKEW, 1:4 SLOPE, H ≤ 8'

VERSION: 2022-03 STANDARD: B14-06 SHEET: 2 OF 2

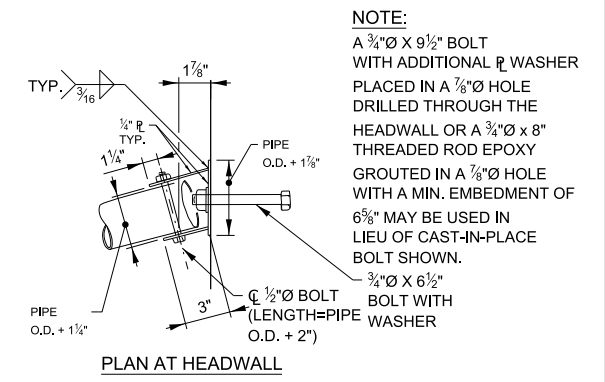
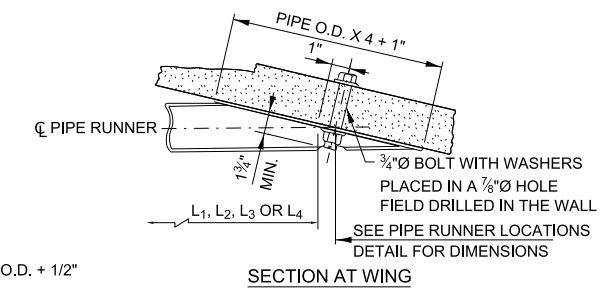
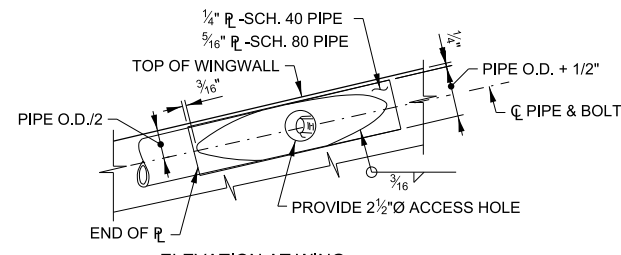
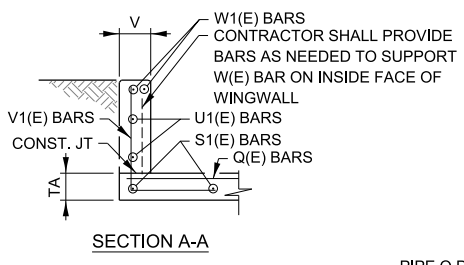
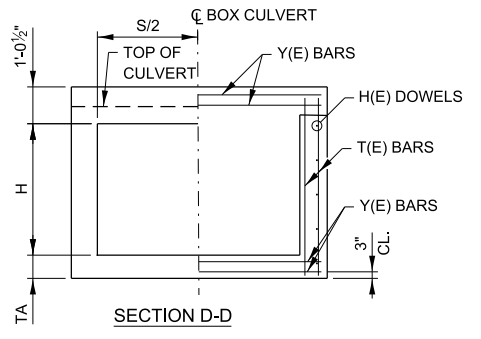
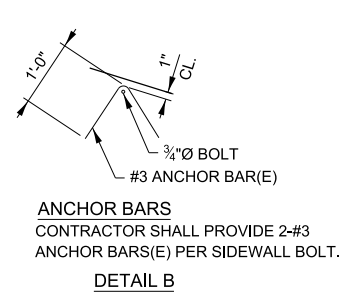

**NOTE:**  
Q, V, AND V1 BARS ARE TO BE FIELD CUT PER CUTTING DIAGRAM. PLACE BARS WITH DIMENSIONS C2-C3, C9-C12 BEGINNING AT HEADWALL AND BARS WITH DIMENSIONS C1-C4, C10-C11 BEGINNING AT THE TOEWALL END.

**NOTE:**  
P1 BARS ARE TO BE FIELD CUT PER CUTTING DIAGRAM PLACE BARS WITH DIMENSIONS C6-C7 BEGINNING AT TOEWALL END OF 30° WING AND BARS WITH DIMENSIONS C5-C8 BEGINNING PARALLEL THE P(E) BARS.

**NOTE:**  
J & H DOWEL BAR NOT REQUIRED WITH EXISTING BOX CULVERTS PROVIDING THE REINFORCING FROM THE EXIST. BOX IS EXTENDED INTO THE NEW CONCRETE A MIN. OF 1'-3".

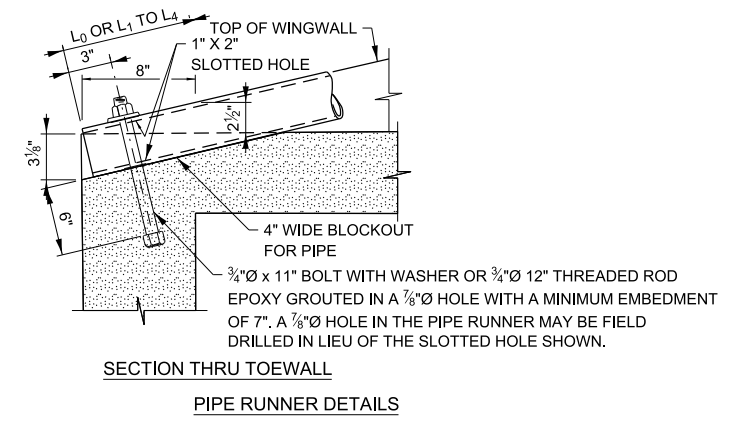
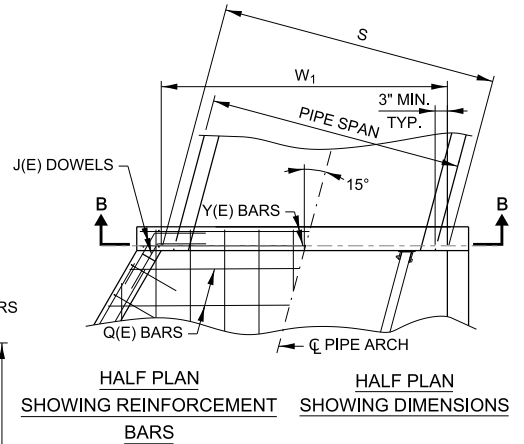
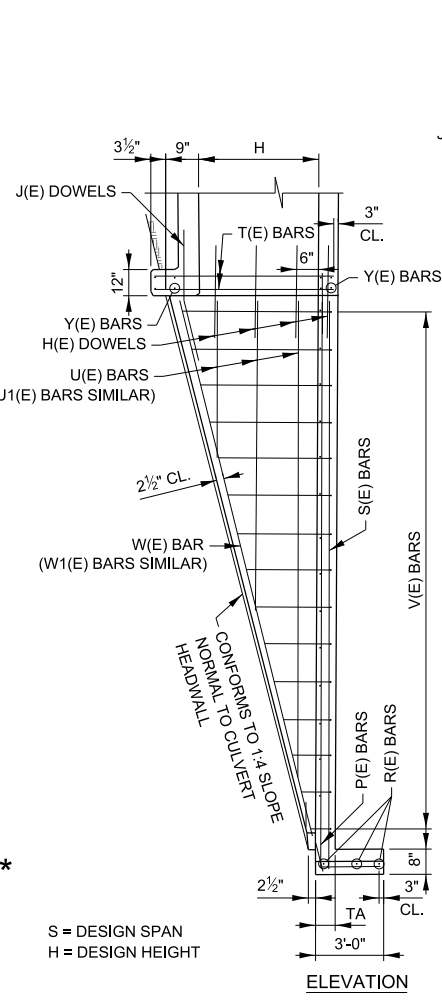
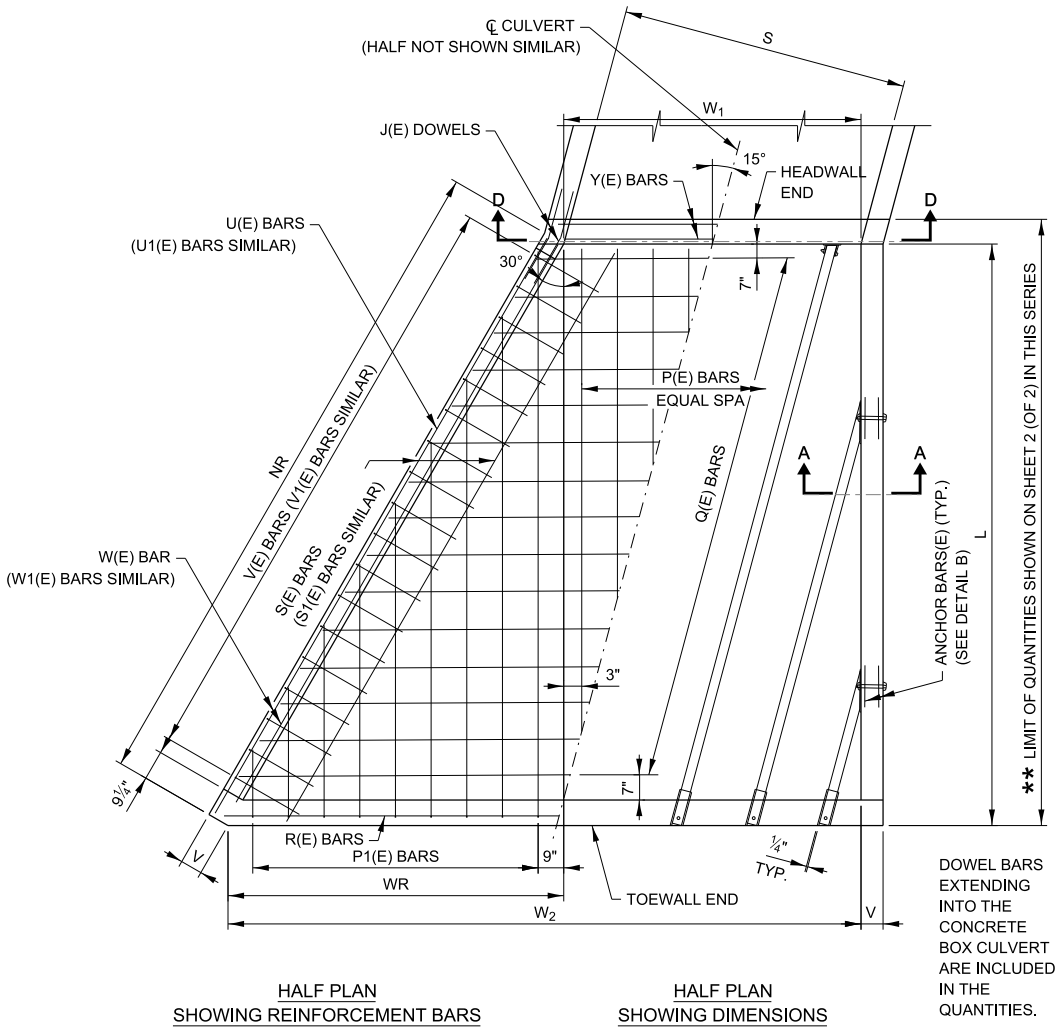
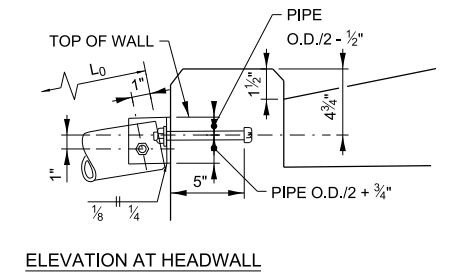
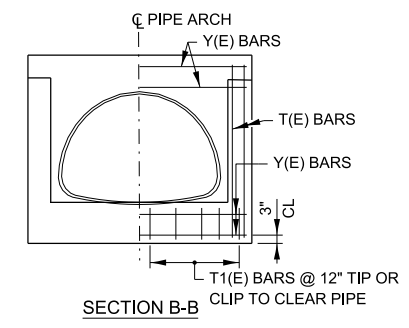

- GENERAL NOTES:**
- ALL CONCRETE SHALL BE CLASS S1.
  - ALL EXPOSED CONCRETE EDGES SHALL HAVE A 3/4" X 45° CHAMFER. CHAMFER ON VERTICAL EDGES SHALL BE CONTINUED A MINIMUM OF ONE FOOT BELOW FINISHED GROUND LEVEL. COVER FROM THE FACE OF CONCRETE TO THE FACE OF REINFORCEMENT BARS SHALL BE 2", UNLESS OTHERWISE SHOWN.
  - CONCRETE QUANTITIES SHOWN ON SHEET 2 (OF 2) IN THIS SERIES ARE FOR REINFORCED CONCRETE BOX CULVERT SECTIONS AND ADDITIONAL CONCRETE REQUIRED IN HEADWALLS FOR PIPE OR ARCH CULVERT SECTIONS SHALL BE ADDED TO THESE QUANTITIES.
  - THIS STANDARD MAY BE USED FOR CULVERTS WITH SKEW OF 15° ± 7.5°. AS SHOWN PER CULVERT SKEW ORIENTATION ON THIS SHEET.
  - DESIGN: SAFETY PIPE RUNNERS ARE DESIGNED FOR A TRANSVERSING LOAD OF 1,800 POUNDS AT YIELD AS RECOMMENDED BY RESEARCH REPORT 280-1, SAFETY TREATMENT OF ROADSIDE CROSS DRAINAGE STRUCTURES, TEXAS TRANSPORTATION INSTITUTE, MARCH 1981.
  - ALL SLOPES ARE EXPRESSED AS UNITS OF VERTICAL DISPLACEMENT TO UNITS OF HORIZONTAL DISPLACEMENT (V:H).
  - FOR EROSION PROTECTION SEE STANDARD B19.
  - ALL REINFORCEMENT BARS SHALL BE EPOXY COATED (E).

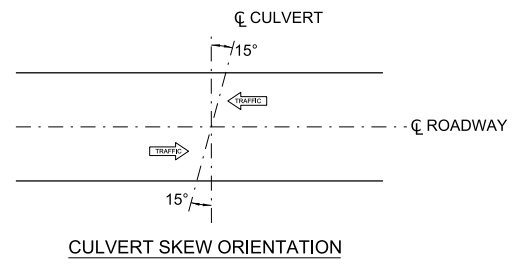
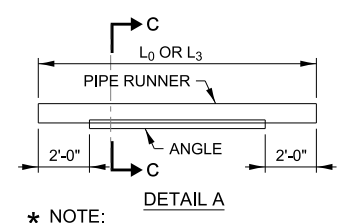

APPROVED BY: *Paul Kovacs*  
CHIEF ENGINEERING OFFICER

DATE: 03/01/2022

REVISIONS	
DATE	DESCRIPTION
03-01-2022	REVISED HEADWALL THICKNESS
03-11-2015	REVISED NOTES
02-07-2012	TABLE QUANTITIES REVISED
03-01-2010	MODIFIED CULVERT SKEW
03-01-2010	DETAIL, REVISED EROSION PROTECTION AND NOTES

**Illinois Tollway**

**END TREATMENT WITH PIPE RUNNERS, FOR SINGLE CULVERTS**

**15° SKEW, 1:4 SLOPE, H ≤ 4**

VERSION: 2022-03      STANDARD: B15-05      SHEET: 1 OF 2





L	H	L	NL	NR	WW	W <sub>1</sub> (4)	W <sub>2</sub> (4)	WR	WF	TF
9'	3'	14'-4"	14'-4"	16'-6 <sup>3</sup> / <sub>4</sub> "	7"	9'-3 <sup>3</sup> / <sub>4</sub> "	17'-7"	8'-3 <sup>1</sup> / <sub>2</sub> "	3"	7"
9'	4'	18'-4"	18'-4"	21'-2"	7"	9'-3 <sup>3</sup> / <sub>4</sub> "	19'-10 <sup>3</sup> / <sub>4</sub> "	10'-7"	9"	8"
5'	5'	22'-4"	22'-4"	25'-9 <sup>1</sup> / <sub>2</sub> "	7"	5'-2"	18'-0 <sup>3</sup> / <sub>4</sub> "	12'-10 <sup>3</sup> / <sub>4</sub> "	1'-3"	8"
6'	6'	26'-4"	26'-4"	30'-4 <sup>1</sup> / <sub>2</sub> "	7"	6'-2 <sup>1</sup> / <sub>2</sub> "	21'-5"	15'-2 <sup>1</sup> / <sub>2</sub> "	1'-9"	8 <sup>1</sup> / <sub>2</sub> "
7'	7'	30'-4"	30'-4"	35'-0 <sup>1</sup> / <sub>4</sub> "	7 <sup>1</sup> / <sub>2</sub> "	7'-3"	24'-9"	17'-6"	2'-3"	9"
8'	8'	34'-4"	34'-4"	39'-7 <sup>3</sup> / <sub>4</sub> "	9 <sup>1</sup> / <sub>2</sub> "	8'-3 <sup>1</sup> / <sub>2</sub> "	28'-1 <sup>1</sup> / <sub>4</sub> "	19'-9 <sup>3</sup> / <sub>4</sub> "	2'-9"	9 <sup>1</sup> / <sub>2</sub> "

H	SIZE (DIA.)	SCHEDULE	WINGWALL PIPES - ONE PER EACH LENGTH SHOWN						HEADWALL PIPE			
			0° WALL			30° WALL			S	NO.	Lo	TOTAL LENGTH
			L <sub>1</sub>	L <sub>2</sub>	L <sub>3</sub>	L <sub>4</sub>	L <sub>5</sub>	L <sub>6</sub>				
3'	3"	40	10'-0"	-	-	10'-8"	-	-	9'	4	15'-1"	81.00
4'	3"	40	14'-3"	-	-	14'-11"	6'-2"	-	9'	4	19'-4"	112.67
5'	3 <sup>1</sup> / <sub>2</sub> "	40	18'-6"	8'-3"	-	19'-2"	10'-5"	-	5'	2	23'-7"	103.50
6'	3 <sup>1</sup> / <sub>2</sub> "	80	22'-9"	12'-6"	-	23'-5"	14'-8"	5'-9"	6'	3	28'-0"	162.08
7'	4"	40	27'-0"	16'-9"	6'-7"	27'-8"	18'-11"	10'-0"	7'	3	32'-3"	203.67
8'	4"	80	31'-3"	21'-0"	10'-10"	31'-11"	23'-2"	14'-3"	8'	4	36'-6"	277.42

NOTE:  
REINFORCEMENT BARS BENDING DIMENSIONS ARE OUT TO OUT.

H	1-C(E) BAR 30° WALL		1-C1(E) BAR 0° WALL		D(E) BAR 4-#4 30° WALL	D1(E) BAR 4-#4 0° WALL	#4-E(E) BARS 30° WALL (6)		#4-E1(E) BARS 0° WALL (6)	
	SIZE	LENGTH	SIZE	LENGTH	LENGTH	LENGTH	NO.	LENGTH	NO.	LENGTH
3'	#4	16'-11"	#4	14'-8"	18'-10"	16'-7"	2	18'-4"	2	16'-2"
4'	#4	21'-7"	#4	18'-8"	23'-6"	20'-7"	2	23'-0"	2	20'-2"
5'	#4	22'-2"	#4	22'-8"	24'-1"	24'-7"	2	27'-7"	2	24'-2"
6'	#4	30'-9"	#4	26'-8"	32'-8"	28'-7"	3	32'-3"	3	28'-2"
7'	#5	35'-5"	#5	30'-8"	37'-4"	32'-7"	3	36'-10"	3	32'-2"
8'	#5	40'-0"	#5	34'-8"	41'-11"	36'-7"	3	41'-6"	3	36'-2"

S	H	TOTAL QUANTITIES ONE END MINIMUM "S"		INCREASE IN QUANTITIES FOR 1' INCREASE IN "S"	
		CONC. CU. YD.	REINF. BARS POUND	CONC. CU. YD.	REINF. BARS POUND
9'	3'	8.4	890	0.20	30
9'	4'	12.7	1120	0.20	30
5'	5'	14.4	1200	0.20	30
6'	6'	20.1	1610	0.20	30
7'	7'	27.0	1930	0.20	30
8'	8'	36.0	2460	0.20	30

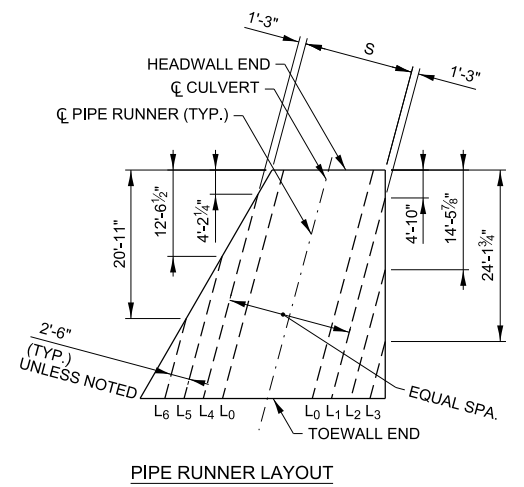

H	F(E) BARS EQUALLY SPACED 30° WALL						F1(E) BARS EQUALLY SPACED 0° WALL						H(E) DOWELS #5 @ 12" 30° WALL		H1(E) DOWELS #5 @ 12" 0° WALL		J(E) DOWELS 4-#6 (5)		1-K(E) BAR 30° WALL		1-K1(E) BAR 0° WALL		2-W(E) BARS 30° WALL		2-W1(E) BARS 0° WALL			
	SIZE	NO.	C <sub>1</sub>	C <sub>2</sub>	C <sub>3</sub>	LENGTH	SIZE	NO.	C <sub>1</sub>	C <sub>2</sub>	C <sub>3</sub>	C <sub>4</sub>	LENGTH	NO.	LENGTH	NO.	LENGTH	LENGTH	SIZE	C <sub>5</sub>	LENGTH	SIZE	C <sub>6</sub>	LENGTH	SIZE	LENGTH	SIZE	LENGTH
3'	#4	7	1'-11"	2'-1"	2'-0"	9'-2"	#4	7	1'-11"	2'-1"	2'-0"	2'-0"	9'-2"	3	3'-0"	3	3'-0"	4'-6"	#5	3'-11"	5'-5"	#5	3'-9"	5'-3"	#5	16'-9"	#5	14'-6"
4'	#4	9	1'-11"	2'-7"	2'-3"	9'-8"	#4	9	1'-11"	2'-7"	2'-3"	2'-3"	9'-8"	4	3'-0"	4	3'-0"	4'-6"	#5	4'-6"	6'-0"	#5	4'-3"	5'-9"	#6	21'-6"	#6	18'-7"
5'	#4	11	1'-11"	3'-1"	2'-6"	10'-2"	#4	11	1'-11"	3'-1"	2'-6"	2'-6"	10'-2"	5	3'-0"	5	3'-0"	4'-6"	#5	5'-1"	6'-7"	#5	4'-9"	6'-3"	#6	26'-3"	#6	22'-9"
6'	#5	13	1'-11"	3'-8"	2'-9"	10'-9"	#5	13	1'-11"	3'-8"	2'-8"	2'-8"	10'-7"	6	3'-0"	6	3'-0"	4'-6"	#5	5'-8"	7'-2"	#5	5'-3"	6'-9"	#6	31'-10"	#6	26'-11"
7'	#5	15	2'-0"	4'-3"	3'-1"	11'-5"	#5	15	2'-0"	4'-1"	3'-0"	3'-1"	11'-3"	7	3'-0"	7	3'-0"	4'-6"	#5	6'-3"	7'-9"	#5	5'-9"	7'-3"	#6	35'-9"	#6	31'-0"
8'	#6	18	2'-1"	4'-10"	3'-5"	12'-1"	#6	17	2'-1"	4'-8"	3'-4"	3'-5"	11'-11"	8	3'-0"	8	3'-0"	4'-6"	#5	6'-10"	8'-4"	#5	6'-3"	7'-9"	#6	40'-6"	#6	35'-2"

H	U(E) BARS - ONE PER EACH LENGTH SHOWN #4 @ 12" 30° WALL						U1(E) BARS - ONE PER EACH LENGTH SHOWN #4 @ 12" 0° WALL						V(E) BARS #5-EQUALLY SPACED 30° WALL						V1(E) BARS #5-EQUALLY SPACED 0° WALL											
	C <sub>7</sub>	C <sub>8</sub>	C <sub>9</sub>	C <sub>10</sub>	C <sub>11</sub>	C <sub>12</sub>	C <sub>13</sub>	C <sub>14</sub>	C <sub>7</sub>	C <sub>8</sub>	C <sub>9</sub>	C <sub>10</sub>	C <sub>11</sub>	C <sub>12</sub>	C <sub>13</sub>	C <sub>14</sub>	NO.	C <sub>15</sub>	C <sub>16</sub>	C <sub>17</sub>	C <sub>18</sub>	C <sub>19</sub>	LENGTH	NO.	C <sub>15</sub>	C <sub>16</sub>	C <sub>17</sub>	C <sub>18</sub>	C <sub>19</sub>	LENGTH
3'	5'-1"	9'-8"	14'-3"	-	-	-	-	-	4'-4"	8'-4"	12'-4"	-	-	-	-	-	30	3'-10"	9"	9"	3'-10"	1'-0"	6'-7"	27	3'-10"	9"	7"	4'-0"	1'-0"	6'-7"
4'	5'-1"	9'-8"	14'-3"	18'-11"	-	-	-	-	4'-4"	8'-4"	12'-4"	16'-4"	-	-	-	-	39	4'-11"	10"	10"	4'-11"	1'-0"	7'-9"	35	4'-11"	10"	8"	5'-1"	1'-0"	7'-9"
5'	5'-1"	9'-8"	14'-3"	18'-11"	23'-6"	-	-	-	4'-4"	8'-4"	12'-4"	16'-4"	20'-4"	-	-	-	48	5'-11"	10"	10"	5'-11"	1'-0"	8'-9"	43	5'-11"	10"	8"	6'-1"	1'-0"	8'-9"
6'	5'-1"	9'-8"	14'-3"	18'-11"	23'-6"	28'-1"	-	-	4'-4"	8'-4"	12'-4"	16'-4"	20'-4"	24'-4"	-	-	57	6'-11"	10"	11"	6'-10"	1'-0"	9'-9"	51	6'-11"	10"	8"	7'-1"	1'-0"	9'-9"
7'	5'-1"	9'-8"	14'-3"	18'-11"	23'-6"	28'-1"	32'-9"	-	4'-4"	8'-4"	12'-4"	16'-4"	20'-4"	24'-4"	28'-4"	-	67	8'-0"	11"	11"	8'-0"	1'-0"	10'-11"	59	8'-0"	11"	9"	8'-2"	1'-0"	10'-11"
8'	5'-1"	9'-8"	14'-3"	18'-11"	23'-6"	28'-1"	32'-9"	37'-4"	4'-4"	8'-4"	12'-4"	16'-4"	20'-4"	24'-4"	28'-4"	32'-4"	76	9'-0"	11"	11"	9'-0"	1'-1"	12'-1"	67	9'-0"	11"	9"	9'-2"	1'-1"	12'-1"

S	H	Y(E) BARS 12-#5 (2)	R(E) BARS 6-#5 (2)	Z(E) BARS #4 @ 12" (1)	S(E) BARS #4 @ 12" (1)	T(E) BARS #4 @ 12" (1)	P(E) BARS 8-#5 (3)			
		LENGTH	LENGTH	NO.	LENGTH	NO.	LENGTH	LENGTH		
≥9'	3'	10'-3"	17'-1"	10	5'-4"	16	6'-10"	10	3'-0"	6'-8"
≥9'	4'	10'-3"	19'-5"	10	5'-4"	18	6'-10"	10	3'-0"	7'-8"
≥5'	5'	6'-1"	17'-7"	6	5'-4"	16	6'-10"	6	3'-0"	8'-8"
≥6'	6'	7'-2"	20'-11"	7	5'-4"	20	6'-10"	7	3'-0"	9'-8"
≥7'	7'	8'-2"	24'-3"	8	5'-4"	23	6'-10"	8	3'-0"	10'-8"
≥8'	8'	9'-4"	27'-8"	9	5'-4"	26	6'-10"	9	3'-0"	11'-8"

S	NO.	S	NO.
10'	4	23'	10
11'	5	24'	10
12'	5	25'	10
13'	6	26'	11
14'	6	27'	11
15'	6	28'	12
16'	7	29'	12
17'	7	30'	12
18'	8	31'	13
19'	8	32'	13
20'	8	33'	14
21'	9	34'	14
22'	9	35'	14

- NOTES FOR TABLES:
- THE NUMBER OF S, T AND Z BARS SHALL BE INCREASED BY 1 FOR EACH 1 FOOT OF INCREASE IN DIMENSION "W<sub>1</sub>".
  - THE LENGTH OF R AND Y BARS SHALL BE INCREASED BY 1'-1<sup>1</sup>/<sub>2</sub>" FOR EACH 1 FOOT OF INCREASE IN DIMENSION "S".
  - THE NUMBER OF P BARS SHOWN ARE FOR SINGLE SPAN PIPES OR BOX CULVERTS. THIS NUMBER SHALL BE INCREASED BY 4 FOR EACH MULTIPLE OF PIPE OR BOX ADDED.
  - THIS DIMENSION SHALL BE INCREASED BY 1'-1<sup>1</sup>/<sub>2</sub>" INCHES FOR EACH 1 FOOT INCREASE IN DIMENSION "S".
  - 2 BARS FOR 30° WALL, 2 BARS FOR 0° WALL.
  - THE LENGTH OF THIS BAR INCLUDES ONE 1'-6" MINIMUM LAP.

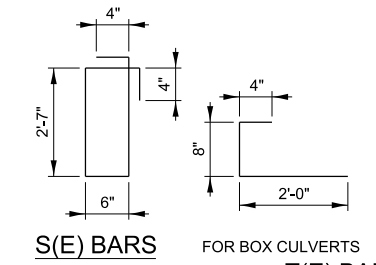
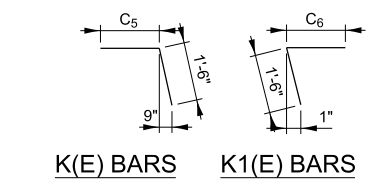
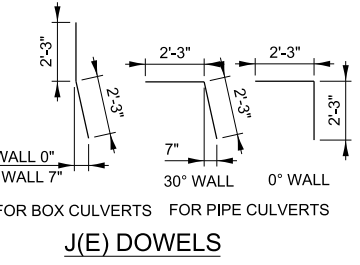
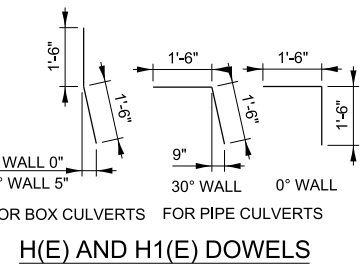
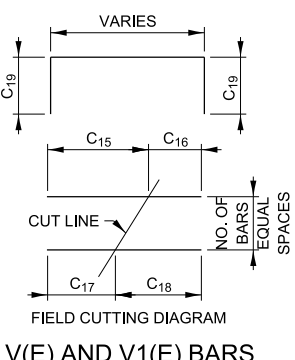
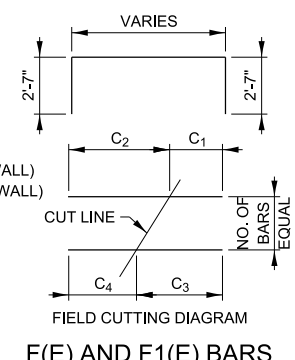
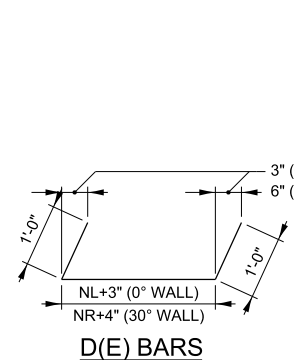

APPROVED BY: *Paul Kovacs*  
CHIEF ENGINEERING OFFICER  
DATE: 03/01/2022

**END TREATMENT WITH PIPE RUNNERS, FOR SINGLE AND MULTIPLE CULVERTS**  
15° SKEW, 1:4 SLOPE, H ≤ 8'

VERSION: 2022-03      STANDARD: B16-06      SHEET: 2 OF 2

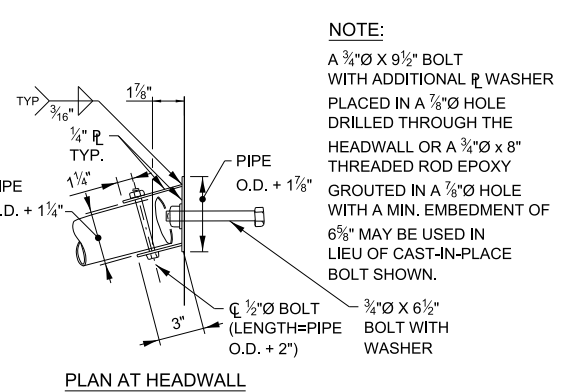
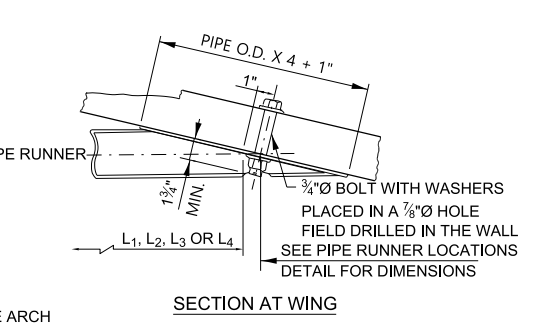
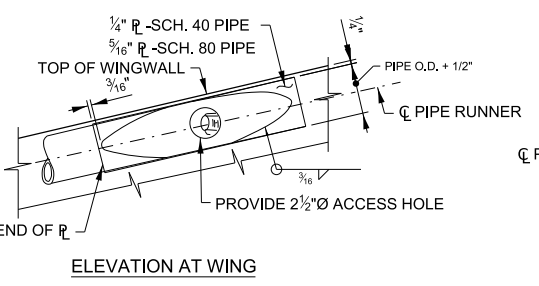
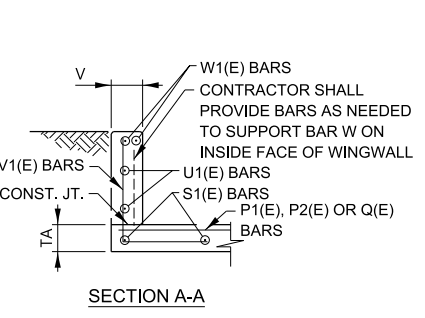
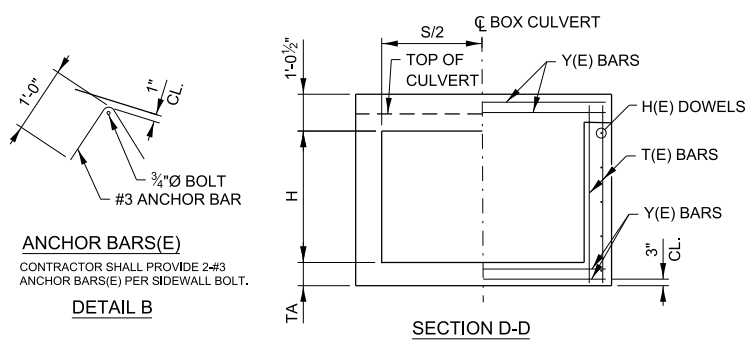

**NOTE:**  
Q(E), V(E), AND V1(E) BARS ARE TO BE FIELD CUT PER CUTTING DIAGRAM. PLACE BARS WITH DIMENSIONS C2-C3, C9-C12 BEGINNING AT HEADWALL AND BARS WITH DIMENSIONS C1-C4, C10-C11 BEGINNING AT THE TOEWALL END.

**NOTE:**  
P1(E) BARS ARE TO BE FIELD CUT PER CUTTING DIAGRAM. PLACE BARS WITH DIMENSIONS C6-C7 BEGINNING AT THE TOEWALL END OF 45° WINGWALL AND BARS WITH DIMENSIONS C5-C8 BEGINNING PARALLEL TO THE P(E) BARS. PLACE P2(E) BARS PARALLEL TO THE P(E) BARS BEGINNING WITH THE SHORTEST BARS AT THE HEADWALL END OF THE 15° WINGWALL.

**NOTE:**  
J(E) & H(E) DOWEL BARS NOT REQUIRED WITH EXISTING BOX CULVERTS PROVIDING THE REINFORCING FROM THE EXIST. BOX IS EXTENDED INTO THE NEW CONCRETE A MIN. OF 1'-3".

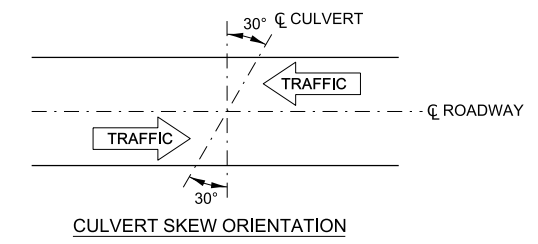
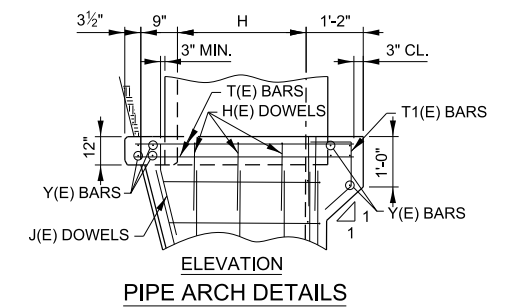
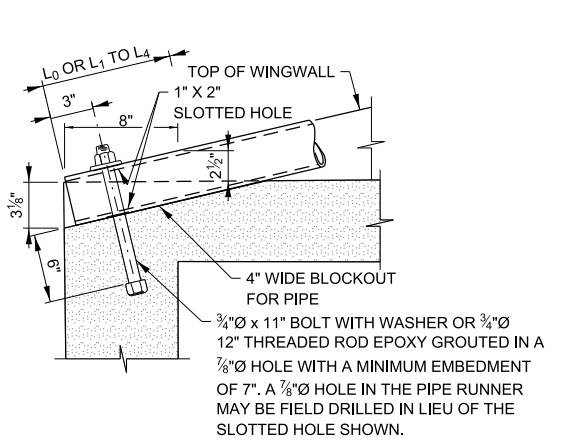
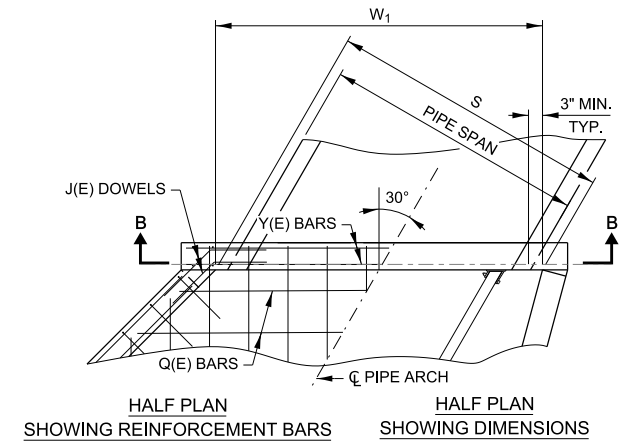
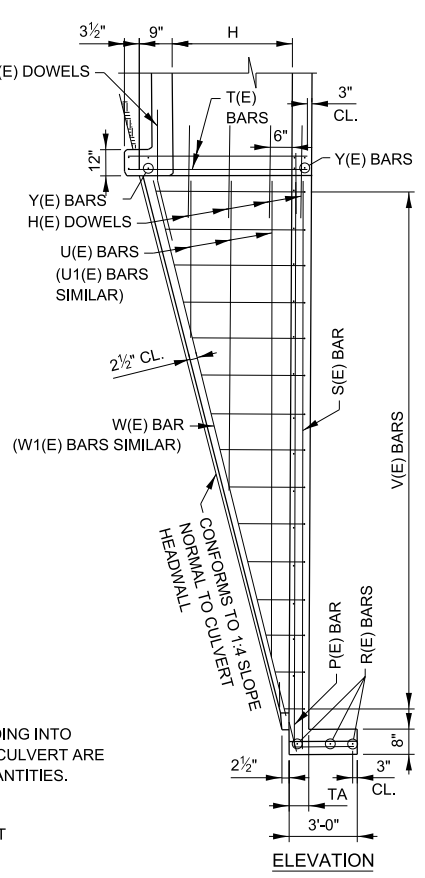
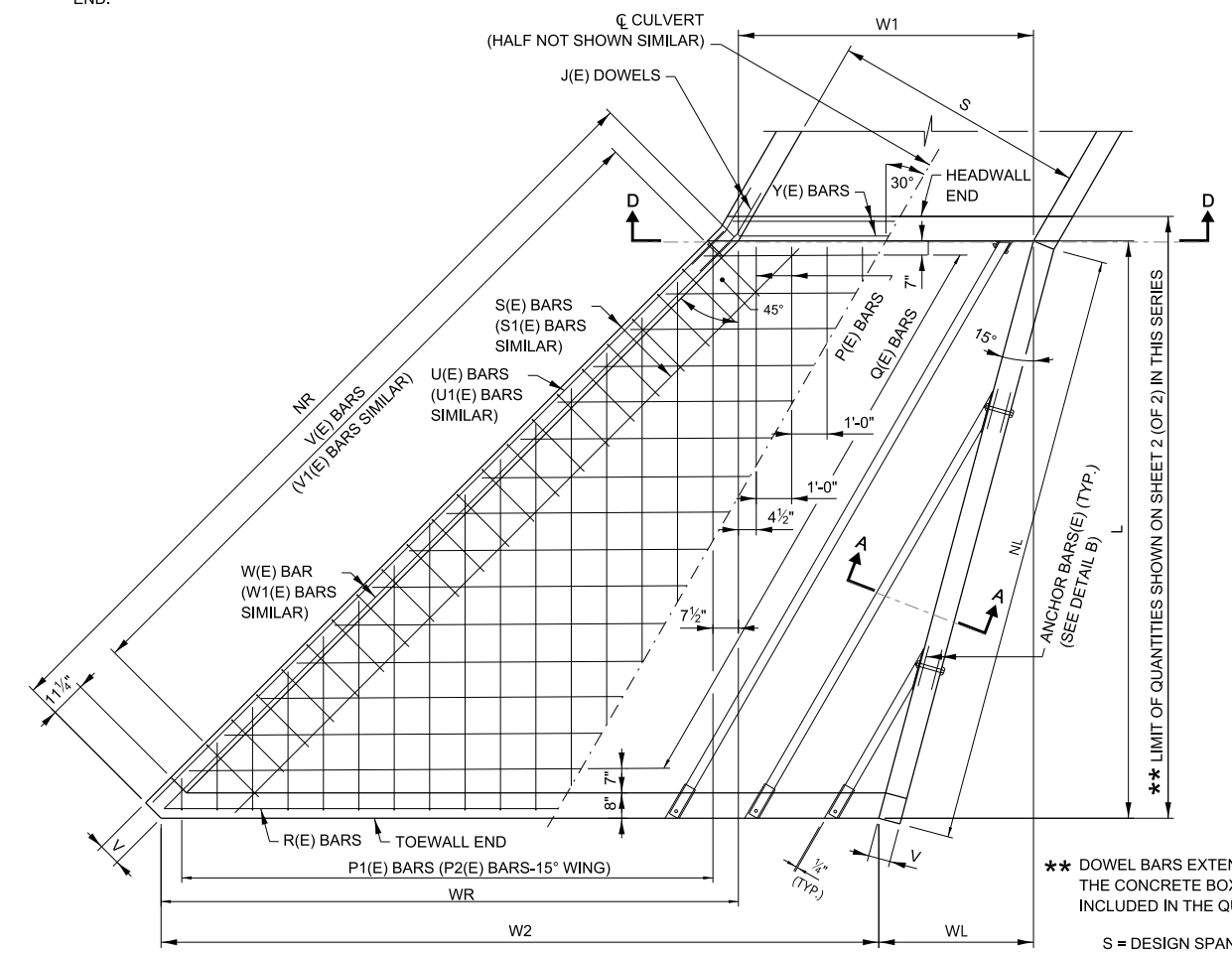
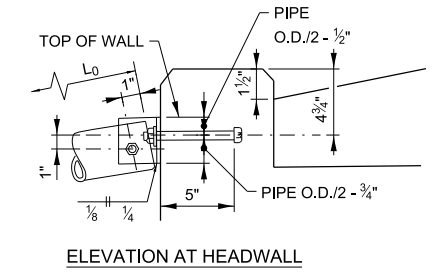
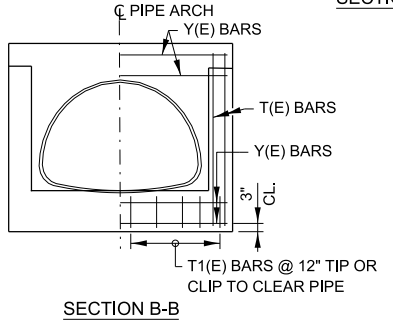

**GENERAL NOTES:**

- ALL CONCRETE SHALL BE CLASS SI.
- ALL EXPOSED CONCRETE EDGES SHALL HAVE A 3/4" x 45° CHAMFER. CHAMFER ON VERTICAL EDGES SHALL BE CONTINUED A MINIMUM OF ONE FOOT BELOW FINISHED GROUND LEVEL. COVER FROM THE FACE OF CONCRETE TO THE FACE OF REINFORCEMENT BARS SHALL BE 2", UNLESS OTHERWISE SHOWN.
- CONCRETE QUANTITIES SHOWN ON SHEET 2 (OF 2) IN THIS SERIES ARE FOR REINFORCED CONCRETE BOX CULVERT SECTIONS AND ADDITIONAL CONCRETE REQUIRED IN HEADWALLS FOR PIPE OR ARCH CULVERT SECTIONS SHALL BE ADDED TO THESE QUANTITIES.
- THIS STANDARD MAY BE USED FOR CULVERTS WITH SKEW OF 30° ± 7.5°. AS SHOWN PER CULVERT SKEW ORIENTATION ON THIS SHEET.
- DESIGN: SAFETY PIPE RUNNERS ARE DESIGNED FOR A TRANSVERSING LOAD OF 1,800 POUNDS AT YIELD AS RECOMMENDED BY RESEARCH REPORT 280-1, SAFETY TREATMENT OF ROADSIDE CROSS DRAINAGE STRUCTURES, TEXAS TRANSPORTATION INSTITUTE, MARCH 1981.
- ALL SLOPES ARE EXPRESSED AS UNITS OF VERTICAL DISPLACEMENT TO UNITS OF HORIZONTAL DISPLACEMENT (V:H).
- FOR EROSION PROTECTION SEE STANDARD B19.
- ALL REINFORCEMENT BARS SHALL BE EPOXY COATED (E).

**\* NOTE:**  
WHERE L0, L1 OR L3 EXCEEDS THE FOLLOWING LENGTH, THE PIPE RUNNER SHALL BE STRENGTHENED OVER THE MIDSPAN AS SHOWN.

PIPE	LENGTH
3"Ø, SCH. 40	12'-8"
3"Ø, SCH. 80	15'-4"

**PIPE RUNNER DETAILS**

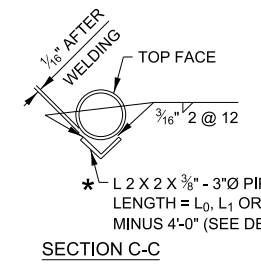

APPROVED BY: *Paul Kovacs*  
CHIEF ENGINEERING OFFICER  
DATE: 03/01/2022

REVISIONS	
DATE	DESCRIPTION
03-01-2022	REVISED HEADWALL THICKNESS AND REBAR TABLE
03-11-2015	REVISED NOTES
02-07-2012	TABLE QUANTITIES REVISED

**Illinois Tollway**

**END TREATMENT WITH PIPE RUNNERS, FOR SINGLE CULVERTS**  
**30° SKEW, 1:4 SLOPE, H ≤ 4'**

VERSION: 2022-03  
STANDARD: B17-05  
SHEET: 1 OF 2

CULVERT SIZE (FEET)	TABLE OF DIMENSIONS									
	S X H	L	NL	NR	V	W <sub>1</sub>	W <sub>2</sub>	WL	WR	TA
3 x 2	10'-10"	11'-2 <sup>5</sup> / <sub>8</sub> "	15'-3 <sup>3</sup> / <sub>8</sub> "	7"	3'-5 <sup>5</sup> / <sub>8</sub> "	11'-4 <sup>3</sup> / <sub>8</sub> "	2'-10 <sup>1</sup> / <sub>8</sub> "	10'-10"	6"	
3 x 3	14'-10"	15'-4 <sup>1</sup> / <sub>4</sub> "	20'-11 <sup>3</sup> / <sub>8</sub> "	7"	3'-5 <sup>5</sup> / <sub>8</sub> "	14'-3 <sup>3</sup> / <sub>8</sub> "	3'-11 <sup>3</sup> / <sub>8</sub> "	14'-10"	6"	
4 x 2	10'-10"	11'-2 <sup>5</sup> / <sub>8</sub> "	15'-3 <sup>3</sup> / <sub>8</sub> "	7"	4'-7 <sup>3</sup> / <sub>8</sub> "	12'-6 <sup>1</sup> / <sub>8</sub> "	2'-10 <sup>1</sup> / <sub>8</sub> "	10'-10"	6"	
4 x 3	14'-10"	15'-4 <sup>1</sup> / <sub>4</sub> "	20'-11 <sup>3</sup> / <sub>8</sub> "	7"	4'-7 <sup>3</sup> / <sub>8</sub> "	15'-5 <sup>5</sup> / <sub>8</sub> "	3'-11 <sup>3</sup> / <sub>8</sub> "	14'-10"	6"	
4 x 4	18'-10"	19'-6"	26'-7 <sup>3</sup> / <sub>8</sub> "	7"	4'-7 <sup>3</sup> / <sub>8</sub> "	18'-4 <sup>3</sup> / <sub>8</sub> "	5'-0 <sup>1</sup> / <sub>2</sub> "	18'-10"	6"	
5 x 2	10'-10"	11'-2 <sup>5</sup> / <sub>8</sub> "	15'-3 <sup>3</sup> / <sub>8</sub> "	7"	5'-9 <sup>1</sup> / <sub>4</sub> "	13'-8 <sup>3</sup> / <sub>8</sub> "	2'-10 <sup>1</sup> / <sub>8</sub> "	10'-10"	6"	
5 x 3	14'-10"	15'-4 <sup>1</sup> / <sub>4</sub> "	20'-11 <sup>3</sup> / <sub>8</sub> "	7"	5'-9 <sup>1</sup> / <sub>4</sub> "	16'-7 <sup>3</sup> / <sub>8</sub> "	3'-11 <sup>3</sup> / <sub>8</sub> "	14'-10"	6"	
5 x 4	18'-10"	19'-6"	26'-7 <sup>3</sup> / <sub>8</sub> "	7"	5'-9 <sup>1</sup> / <sub>4</sub> "	19'-6 <sup>1</sup> / <sub>8</sub> "	5'-0 <sup>1</sup> / <sub>2</sub> "	18'-10"	6"	
6 x 3	14'-10"	15'-4 <sup>1</sup> / <sub>4</sub> "	20'-11 <sup>3</sup> / <sub>8</sub> "	7"	6'-11 <sup>1</sup> / <sub>8</sub> "	17'-9 <sup>3</sup> / <sub>8</sub> "	3'-11 <sup>3</sup> / <sub>8</sub> "	14'-10"	6"	
6 x 4	18'-10"	19'-6"	26'-7 <sup>3</sup> / <sub>8</sub> "	7"	6'-11 <sup>1</sup> / <sub>8</sub> "	20'-8 <sup>3</sup> / <sub>8</sub> "	5'-0 <sup>1</sup> / <sub>2</sub> "	18'-10"	6"	
7 x 3	14'-10"	15'-4 <sup>1</sup> / <sub>4</sub> "	20'-11 <sup>3</sup> / <sub>8</sub> "	7"	8'-1"	18'-11 <sup>3</sup> / <sub>8</sub> "	3'-11 <sup>3</sup> / <sub>8</sub> "	14'-10"	6 <sup>1</sup> / <sub>2</sub> "	
7 x 4	18'-10"	19'-6"	26'-7 <sup>3</sup> / <sub>8</sub> "	7"	8'-1"	21'-10 <sup>1</sup> / <sub>2</sub> "	5'-0 <sup>1</sup> / <sub>2</sub> "	18'-10"	6 <sup>1</sup> / <sub>2</sub> "	
8 x 4	18'-10"	19'-6"	26'-7 <sup>3</sup> / <sub>8</sub> "	7"	9'-2 <sup>1</sup> / <sub>8</sub> "	23'-0 <sup>3</sup> / <sub>8</sub> "	5'-0 <sup>1</sup> / <sub>2</sub> "	18'-10"	7"	

SCHEDULE	PIPE RUNNERS FOR ONE END SIZE 3" DIA.					
	HEADWALL PIPE		WINGWALL PIPE-ONE PER EACH LENGTH SHOWN			
	NO.	L <sub>0</sub>	15° WALL		45° WALL	
40	2	12'-10"	7'-10"	-	9'-2"	-
40	2	17'-8"	12'-6"	-	13'-11"	6'-7"
40	2	12'-10"	7'-10"	-	9'-2"	-
40	2	17'-8"	12'-6"	-	13'-11"	6'-7"
80	2	22'-4"	18'-10"	7'-4"	18'-7"	11'-4"
40	3	12'-10"	7'-10"	-	9'-2"	-
40	3	17'-8"	12'-6"	-	13'-11"	6'-7"
80	3	22'-4"	17'-3"	7'-4"	18'-7"	11'-4"
40	3	17'-8"	12'-6"	-	13'-11"	6'-7"
80	3	22'-4"	17'-3"	7'-4"	18'-7"	11'-4"
40	4	17'-8"	12'-6"	-	13'-11"	6'-7"
80	4	22'-4"	17'-3"	7'-4"	18'-7"	11'-4"

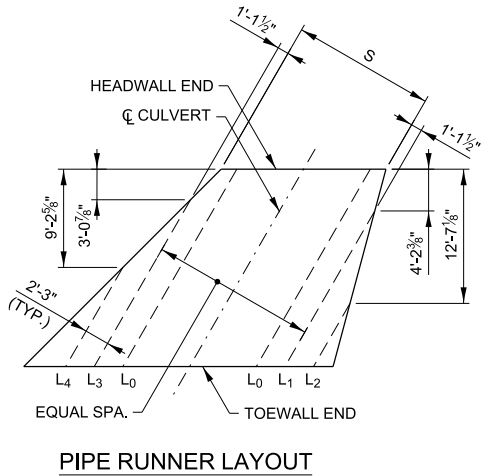

CULVERT SIZE (FEET)	TABLE OF REINFORCEMENT BARS FOR ONE END																													
	H(E) DOWELS #4 @ 12" 2'-6" LG.		J(E) DOWELS #4 @ 12" 4'-0" LG.		P(E) BARS #4 @ 12"		P1(E) BARS #4 @ 12"					P2(E) BARS - ONE PER EACH LENGTH SHOWN #4 @ 12"					Q(E) BARS #4 @ 12"				R(E) BARS 3-#4	S(E) BARS 45° WALL 2-#4	S1(E) BARS 15° WALL 2-#4	U(E) BARS-ONE PER EACH LENGTH SHOWN #4 @ 12" 45° WALL						
	NO.*	NO.**	NO.*	NO.**	NO.	LENGTH	NO.	C <sub>5</sub>	C <sub>6</sub>	C <sub>7</sub>	C <sub>8</sub>	LENGTH	a <sub>1</sub>	a <sub>2</sub>	a <sub>3</sub>	a <sub>4</sub>	a <sub>5</sub>	NO.	C <sub>1</sub>	C <sub>2</sub>	C <sub>3</sub>	C <sub>4</sub>	LENGTH	LENGTH	LENGTH	LENGTH	a <sub>6</sub>	a <sub>7</sub>	a <sub>8</sub>	a <sub>9</sub>
3 x 2	3	3	2	2	1	13'-1"	5	10'-6"	1'-6"	5'-6"	6'-6"	17'-2"	5'-4"	9'-1"	-	-	-	5	11'-6"	4'-11"	7'-10"	8'-7"	16'-5"	11'-10"	14'-10"	11'-0"	6'-2"	11'-10"	-	-
3 x 3	4	4	2	2	0	-	7	14'-6"	1'-6"	7'-6"	8'-6"	21'-2"	5'-4"	9'-1"	12'-10"	-	-	7	14'-5"	4'-11"	9'-4"	10'-0"	19'-4"	14'-9"	20'-6"	15'-2"	6'-2"	11'-10"	17'-6"	-
4 x 2	3	3	2	2	2	13'-1"	5	10'-6"	1'-6"	5'-6"	6'-6"	17'-2"	2'-3"	6'-0"	9'-9"	-	-	5	12'-8"	6'-1"	9'-0"	10'-0"	13'-0"	14'-10"	11'-0"	6'-2"	11'-10"	-	-	
4 x 3	4	4	2	2	1	17'-1"	7	14'-6"	1'-6"	7'-6"	8'-6"	21'-2"	2'-3"	6'-0"	9'-9"	13'-6"	-	7	15'-7"	6'-1"	10'-6"	11'-2"	21'-8"	15'-11"	20'-6"	15'-2"	6'-2"	11'-10"	17'-6"	-
4 x 4	5	5	2	2	0	-	9	18'-6"	1'-6"	9'-6"	10'-6"	25'-2"	2'-3"	6'-0"	9'-9"	13'-6"	17'-3"	9	18'-6"	6'-1"	11'-11"	12'-8"	24'-7"	18'-10"	26'-2"	19'-4"	6'-2"	11'-10"	17'-6"	23'-1"
5 x 2	3	3	2	2	3	13'-1"	5	10'-6"	1'-6"	5'-6"	6'-6"	17'-2"	2'-10"	6'-7"	10'-4"	-	-	5	13'-10"	7'-3"	10'-2"	10'-11"	21'-1"	14'-2"	14'-10"	11'-0"	6'-2"	11'-10"	-	-
5 x 3	4	4	2	2	2	17'-1"	7	14'-6"	1'-6"	7'-6"	8'-6"	21'-2"	2'-10"	6'-7"	10'-4"	14'-0"	-	7	16'-9"	7'-3"	11'-8"	12'-4"	24'-0"	17'-1"	20'-6"	15'-2"	6'-2"	11'-10"	17'-6"	-
5 x 4	5	5	2	2	1	21'-1"	9	18'-6"	1'-6"	9'-6"	10'-6"	25'-2"	2'-10"	6'-7"	10'-4"	14'-0"	17'-9"	9	19'-8"	7'-3"	13'-1"	13'-10"	26'-11"	20'-0"	26'-2"	19'-4"	6'-2"	11'-10"	17'-6"	23'-1"
6 x 3	4	4	2	2	3	17'-1"	7	14'-6"	1'-6"	7'-6"	8'-6"	21'-2"	3'-4"	7'-1"	10'-10"	14'-7"	-	7	17'-11"	8'-4"	12'-9"	13'-6"	26'-3"	18'-3"	20'-6"	15'-2"	6'-2"	11'-10"	17'-6"	-
6 x 4	5	5	2	2	2	21'-1"	9	18'-6"	1'-6"	9'-6"	10'-6"	25'-2"	3'-4"	7'-1"	10'-10"	14'-7"	18'-3"	9	20'-10"	8'-4"	14'-3"	14'-11"	29'-2"	21'-2"	26'-2"	19'-4"	6'-2"	11'-10"	17'-6"	23'-1"
7 x 3	4	4	2	2	4	17'-1"	7	14'-6"	1'-6"	7'-6"	8'-6"	21'-2"	4'-0"	7'-9"	10'-10"	15'-2"	-	7	19'-1"	9'-6"	13'-11"	14'-8"	28'-7"	19'-5"	20'-6"	15'-2"	6'-2"	11'-10"	17'-6"	-
7 x 4	5	5	2	2	3	21'-1"	9	18'-6"	1'-6"	9'-6"	10'-6"	25'-2"	4'-0"	7'-9"	11'-5"	15'-2"	18'-6"	9	22'-0"	9'-6"	15'-5"	16'-1"	31'-6"	22'-4"	26'-2"	19'-4"	6'-2"	11'-10"	17'-6"	23'-1"
8 x 4	5	5	2	2	5	21'-1"	9	18'-6"	1'-6"	9'-6"	10'-6"	25'-2"	4'-6"	8'-3"	12'-0"	15'-9"	-	9	23'-1"	10'-8"	16'-6"	17'-3"	33'-9"	23'-6"	26'-2"	19'-4"	6'-2"	11'-10"	17'-6"	23'-1"

CULVERT SIZE (FEET)	TABLE OF REINFORCEMENT BARS FOR ONE END																						
	U1(E) BARS-ONE PER EACH LENGTH SHOWN #4 @ 12" 15° WALL				V(E) BARS #4 @ 10.5" 45° WALL				V1(E) BARS #4 @ 10.5" 15° WALL					2 W(E) BARS 45° WALL		2 W1(E) BARS 15° WALL		Y(E) BARS 8-#5	T(E) BARS 8-#5 BOX CULVERT	T(E) BARS 8-#5 PIPE ARCH			
	a <sub>10</sub>	a <sub>11</sub>	a <sub>12</sub>	a <sub>13</sub>	No.	C <sub>9</sub>	C <sub>10</sub>	C <sub>11</sub>	C <sub>12</sub>	LENGTH	No.	C <sub>9</sub>	C <sub>10</sub>	C <sub>11</sub>	C <sub>12</sub>	LENGTH	SIZE	LENGTH	SIZE	LENGTH	LENGTH	LENGTH	LENGTH
3 x 2	4'-6"	8'-7"	-	-	16	2'-9"	6"	7"	2'-8"	6'-3"	12	2'-9"	6"	7"	2'-8"	6'-3"	#5	14'-5"	#5	10'-8"	4'-4"	3'-2"	3'-8"
3 x 3	4'-6"	8'-7"	12'-9"	-	23	3'-9"	6"	6"	3'-9"	7'-3"	16	3'-9"	6"	9"	3'-6"	7'-3"	#5	20'-2"	#5	14'-11"	4'-4"	4'-2"	4'-8"
4 x 2	4'-6"	8'-7"	-	-	16	2'-9"	6"	7"	2'-8"	6'-3"	12	2'-9"	6"	7"	2'-8"	6'-3"	#5	14'-5"	#5	10'-8"	5'-6"	3'-2"	3'-8"
4 x 3	4'-6"	8'-7"	12'-9"	-	23	3'-9"	6"	6"	3'-9"	7'-3"	16	3'-9"	6"	9"	3'-6"	7'-3"	#5	20'-2"	#5	14'-11"	5'-6"	4'-2"	4'-8"
4 x 4	4'-6"	8'-7"	12'-9"	16'-11"	29	4'-9"	6"	7"	4'-8"	8'-3"	21	4'-9"	6"	8"	4'-7"	8'-3"	#6	25'-11"	#6	19'-1"	6'-8"	5'-2"	5'-8"
5 x 2	4'-6"	8'-7"	-	-	16	2'-9"	6"	7"	2'-8"	6'-3"	12	2'-9"	6"	7"	2'-8"	6'-3"	#5	14'-5"	#5	10'-8"	6'-8"	3'-2"	3'-8"
5 x 3	4'-6"	8'-7"	12'-9"	-	23	3'-9"	6"	6"	3'-9"	7'-3"	16	3'-9"	6"	9"	3'-6"	7'-3"	#5	20'-2"	#5	14'-11"	6'-8"	4'-2"	4'-8"
5 x 4	4'-6"	8'-7"	12'-9"	16'-11"	29	4'-9"	6"	7"	4'-8"	8'-3"	21	4'-9"	6"	8"	4'-7"	8'-3"	#6	25'-11"	#6	19'-1"	6'-8"	5'-2"	5'-8"
6 x 3	4'-6"	8'-7"	12'-9"	-	23	3'-9"	6"	6"	3'-9"	7'-3"	16	3'-9"	6"	9"	3'-6"	7'-3"	#5	20'-2"	#5	14'-11"	7'-10"	4'-2"	4'-8"
6 x 4	4'-6"	8'-7"	12'-9"	16'-11"	29	4'-9"	6"	7"	4'-8"	8'-3"	21	4'-9"	6"	8"	4'-7"	8'-3"	#6	25'-11"	#6	19'-1"	7'-10"	5'-2"	5'-8"
7 x 3	4'-6"	8'-7"	12'-9"	-	23	3'-9"	6"	6"	3'-9"	7'-3"	16	3'-9"	6"	9"	3'-6"	7'-3"	#5	20'-2"	#5	14'-11"	9'-0"	4'-2"	4'-8"
7 x 4	4'-6"	8'-7"	12'-9"	16'-11"	29	4'-9"	6"	7"	4'-8"	8'-3"	21	4'-9"	6"	8"	4'-7"	8'-3"	#6	25'-11"	#6	19'-1"	9'-0"	5'-2"	5'-8"
8 x 4	4'-6"	8'-7"	12'-9"	16'-11"	29	4'-9"	6"	7"	4'-8"	8'-3"	21	4'-9"	6"	8"	4'-7"	8'-3"	#6	25'-11"	#6	19'-1"	10'-2"	5'-2"	5'-8"

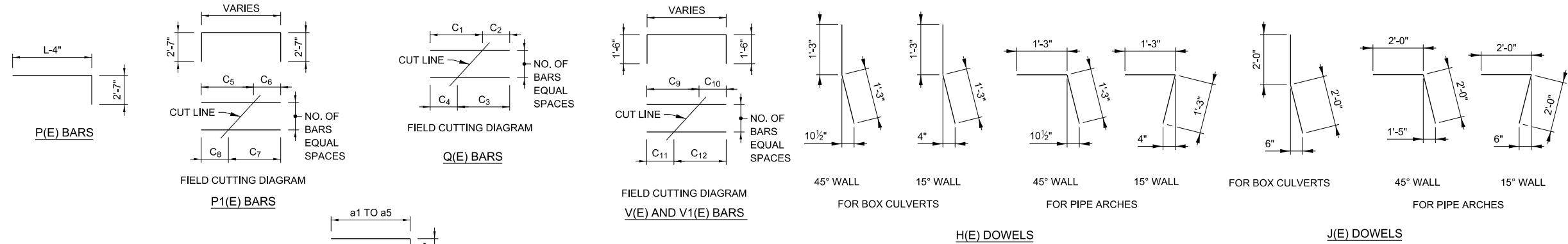

NOTE: REINFORCEMENT BARS BENDING DIMENSIONS ARE OUT TO OUT.

TOTAL QUANTITIES ONE END		
CONC.	REINF. BARS	PIPE RUNNERS
CU. YD.	LB.	FT.
3.8	396	41.67
5.8	580	67.17
4.2	430	41.67
6.3	617	67.17
8.8	874	97.83
4.6	460	54.17
6.8	653	84.42
9.4	915	119.83
7.3	688	84.42
9.9	957	119.83
8.0	724	101.67
10.9	999	141.84
12.0	1042	141.84

\* 45° WALL  
\*\* 15° WALL

PIPE ARCH AND ELLIPTICAL PIPE CULVERTS

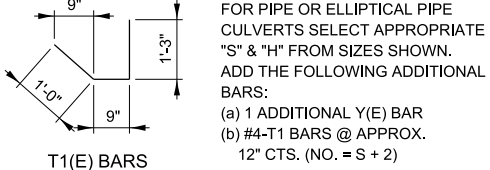

FOR PIPE OR ELLIPTICAL PIPE CULVERTS SELECT APPROPRIATE "S" & "H" FROM SIZES SHOWN. ADD THE FOLLOWING ADDITIONAL BARS:  
(a) 1 ADDITIONAL Y(E) BAR  
(b) #4-T1 BARS @ APPROX. 12" CTS. (NO. = S + 2)

THE WEIGHT OF THE ADDITIONAL BARS AND THE ADDITIONAL QUANTITY OF CONCRETE IN THE HEADWALL SHALL BE ADDED TO THE QUANTITIES SHOWN.

APPROVED BY: *Paul Kovacs*  
CHIEF ENGINEERING OFFICER  
DATE: 03/01/2022

**END TREATMENT WITH PIPE RUNNERS, FOR SINGLE CULVERTS**  
30° SKEW, 1:4 SLOPE, H ≤ 4'

VERSION: 2022-03      STANDARD: B17-05      SHEET: 2 OF 2



TABLE OF DIMENSIONS											
S	H	L	NL	NR	WW	W <sub>1</sub> (4)	W <sub>2</sub> (4)	WL	WR	WF	TF
9'	3'	14'-4"	14'-10 <sup>1</sup> / <sub>8</sub> "	20'-3 <sup>1</sup> / <sub>4</sub> "	7"	10'-4 <sup>3</sup> / <sub>4</sub> "	20'-10 <sup>5</sup> / <sub>8</sub> "	3'-10 <sup>1</sup> / <sub>8</sub> "	14'-4"	3"	7"
9'	4'	18'-4"	18'-11 <sup>3</sup> / <sub>4</sub> "	25'-11 <sup>3</sup> / <sub>4</sub> "	7"	10'-4 <sup>3</sup> / <sub>4</sub> "	23'-9 <sup>3</sup> / <sub>4</sub> "	4'-11"	18'-4"	9"	8"
5'	5'	22'-4"	23'-1 <sup>1</sup> / <sub>2</sub> "	31'-7"	7"	5'-9 <sup>1</sup> / <sub>4</sub> "	22'-1 <sup>1</sup> / <sub>2</sub> "	5'-11 <sup>3</sup> / <sub>4</sub> "	22'-4"	1'-3"	8"
6'	6'	26'-4"	27'-3 <sup>1</sup> / <sub>8</sub> "	37'-2 <sup>1</sup> / <sub>8</sub> "	7"	6'-11 <sup>1</sup> / <sub>8</sub> "	26'-2 <sup>1</sup> / <sub>8</sub> "	7'- <sup>5</sup> / <sub>8</sub> "	26'-4"	1'-9"	8 <sup>1</sup> / <sub>2</sub> "
7'	7'	30'-4"	31'-4 <sup>1</sup> / <sub>8</sub> "	42'-10 <sup>3</sup> / <sub>4</sub> "	8"	8'-1"	30'-3 <sup>1</sup> / <sub>2</sub> "	8'-1 <sup>1</sup> / <sub>2</sub> "	30'-4"	2'-3"	9"
8'	8'	34'-4"	35'-6 <sup>1</sup> / <sub>2</sub> "	48'-6 <sup>5</sup> / <sub>8</sub> "	9"	9'-2 <sup>1</sup> / <sub>8</sub> "	34'-4 <sup>1</sup> / <sub>2</sub> "	9'-2 <sup>1</sup> / <sub>8</sub> "	34'-4"	2'-9"	9 <sup>1</sup> / <sub>2</sub> "

TOTAL QUANTITIES ONE END MINIMUM "S"		INCREASE IN QUANTITIES FOR 1' INCREASE IN "S"	
CONC. CU. YD.	REINF. BARS POUND	CONC. CU. YD.	REINF. BARS POUND
9.8	1010	0.22	33
14.8	1270	0.22	33
16.8	1380	0.22	33
23.5	1860	0.22	33
31.5	2330	0.22	33
42.2	2960	0.22	33

NOTE:  
REINFORCEMENT BARS BENDING DIMENSIONS ARE OUT TO OUT.

PIPE RUNNERS FOR ONE END													TABLE OF REINFORCEMENT BARS FOR ONE END											
H	SIZE (DIA.)	SCHEDULE	WINGWALL PIPES - ONE PER EACH LENGTH SHOWN								HEADWALL PIPES		TOTAL LENGTH	1-C(E) BAR 45° WALL		1-C1(E) BAR 15° WALL		D(E) BAR 4-#4 45° WALL	D1(E) BAR 4-#4 45° WALL	#4-E(E) BARS 45° WALL (6)		#4-E1(E) BARS 15° WALL (6)		
			15° WALL				45° WALL				S	NO.		L <sub>0</sub>	SIZE	LENGTH	SIZE	LENGTH	LENGTH	LENGTH	NO.	LENGTH	NO.	LENGTH
			L <sub>1</sub>	L <sub>2</sub>	L <sub>3</sub>	L <sub>4</sub>	L <sub>5</sub>	L <sub>6</sub>	L <sub>7</sub>	L <sub>8</sub>														
3'	3"	40	11'-11"	-	-	13'-3"	6'-0"	-	-	9'	4	16'-10"	98.50	#4	20'-8"	#4	15'-3"	22'-9"	17'-2"	2	21'-4"	2	17'-0"	
4'	3"	80	16'-8"	-	-	18'-0"	10'-9"	-	-	9'	4	21'-7"	131.75	#4	26'-4"	#4	19'-5"	28'-5"	21'-4"	2	27'-0"	2	21'-1"	
5'	3 <sup>1</sup> / <sub>2</sub> "	80	21'-4"	11'-6"	-	22'-8"	15'-5"	8'-2"	-	5'	3	26'-4"	158.08	#4	32'-0"	#4	23'-7"	34'-1"	25'-6"	2	32'-8"	2	25'-3"	
6'	3 <sup>1</sup> / <sub>2</sub> "	80	26'-1"	16'-2"	-	27'-9"	20'-2"	12'-11"	5'-8"	6'	3	31'-0"	201.75	#4	37'-8"	#4	27'-8"	39'-9"	29'-7"	3	38'-4"	3	29'-4"	
7'	4"	80	30'-10"	20'-11"	11'-0"	32'-2"	24'-9"	17'-8"	10'-9"	7'	4	35'-9"	291.08	#5	44'-10" (6)	#5	31'-10"	46'-11" (6)	33'-9"	3	44'-0"	3	33'-6"	
8'	4"	80	35'-9"	25'-8"	15'-9"	36'-10"	29'-7"	22'-4"	15'-1"	8'	4	40'-6"	350.83	#5	50'-6" (6)	#5	36'-0"	52'-6" (6)	37'-10"	3	49'-8"	3	37'-7"	

TABLE OF REINFORCEMENT BARS FOR ONE END																																	
F(E) BARS EQUALLY SPACED 45° WALL								L(E) BARS 45° WALL				F1(E) BARS EQUALLY SPACED 15° WALL					H(E) DOWELS #5 @ 12" 45° WALL		H(E) DOWELS #5 @ 12" 15° WALL		J(E) DOWELS 4-#6 (5)	1-K(E) BAR 45° WALL		1-K1(E) BAR 15° WALL		2-W(E) BARS 45° WALL		2-W1(E) BARS 15° WALL					
H	SIZE	NO.	C <sub>1</sub>	C <sub>2</sub>	C <sub>3</sub>	C <sub>4</sub>	LENGTH	SIZE	NO.	C <sub>0</sub>	LENGTH	SIZE	NO.	C <sub>1</sub>	C <sub>2</sub>	C <sub>3</sub>	C <sub>4</sub>	LENGTH	NO.	LENGTH	NO.	LENGTH	LENGTH	SIZE	C <sub>5</sub>	LENGTH	SIZE	C <sub>6</sub>	LENGTH	SIZE	LENGTH	SIZE	LENGTH
3'	#4	10	1'-11"	2'-2"	2'-0"	2'-1"	9'-3"	#4	-	-	-	#4	8	1'-11"	2'-2"	2'-0"	2'-1"	9'-3"	3	3'-0"	3	3'-0"	4'-6"	#5	4'-3"	5'-9"	#5	3'-10"	5'-4"	#5	20'-6"	#5	14'-11"
4'	#4	12	1'-11"	2'-8"	2'-3"	2'-4"	9'-9"	#4	1	3'-10"	6'-5"	#4	10	1'-11"	2'-8"	2'-3"	2'-4"	9'-9"	4	3'-0"	4	3'-0"	4'-6"	#5	5'-0"	6'-6"	#5	4'-4"	5'-10"	#6	26'-4"	#6	19'-2"
5'	#4	15	1'-11"	3'-2"	2'-6"	2'-7"	10'-3"	#4	2	4'-6"	7'-1"	#4	12	1'-11"	3'-2"	2'-6"	2'-7"	10'-3"	5	3'-0"	5	3'-0"	4'-6"	#5	5'-8"	7'-2"	#5	4'-10"	6'-4"	#6	32'-2"	#6	23'-5"
6'	#5	18	1'-11"	3'-8"	2'-9"	2'-10"	10'-9"	#5	2	5'-3"	7'-10"	#5	14	1'-11"	3'-8"	2'-9"	2'-10"	10'-9"	6	3'-0"	6	3'-0"	4'-6"	#5	6'-5"	7'-11"	#5	5'-4"	6'-10"	#6	38'-0"	#6	27'-8"
7'	#5	20	2'-0"	4'-3"	3'-1"	3'-2"	11'-5"	#5	3	6'-0"	8'-7"	#5	16	2'-0"	4'-2"	3'-1"	3'-1"	11'-4"	7	3'-0"	7	3'-0"	4'-6"	#5	7'-1"	8'-7"	#5	5'-10"	7'-4"	#7	45'-4" (6)	#7	31'-11"
8'	#6	23	2'-1"	4'-10"	3'-5"	3'-6"	12'-1"	#6	3	6'-9"	9'-4"	#6	18	2'-1"	4'-8"	3'-4"	3'-5"	11'-11"	8	3'-0"	8	3'-0"	4'-6"	#5	7'-10"	9'-4"	#5	6'-5"	7'-11"	#7	51'-2" (6)	#7	36'-2"

NUMBER OF HEADWALL PIPE RUNNERS FOR 1 END			
S	NO.	S	NO.
10'	5	23'	11
11'	5	24'	11
12'	6	25'	12
13'	6	26'	12
14'	7	27'	12
15'	7	28'	13
16'	8	29'	13
17'	8	30'	14
18'	8	31'	14
19'	9	32'	15
20'	9	33'	15
21'	10	34'	16
22'	10	35'	16

TABLE OF REINFORCEMENT BARS FOR ONE END																														
U(E) BARS - ONE PER EACH LENGTH SHOWN #4 @ 12" 45° WALL								U1(E) BARS - ONE PER EACH LENGTH SHOWN #4 @ 12" 15° WALL								V(E) BARS #5-EQUALLY SPACED 45° WALL						V1(E) BARS #5-EQUALLY SPACED 15° WALL								
H	C <sub>7</sub>	C <sub>8</sub>	C <sub>9</sub>	C <sub>10</sub>	C <sub>11</sub>	C <sub>12</sub>	C <sub>13</sub>	C <sub>14</sub> (6)	C <sub>7</sub>	C <sub>8</sub>	C <sub>9</sub>	C <sub>10</sub>	C <sub>11</sub>	C <sub>12</sub>	C <sub>13</sub>	C <sub>14</sub>	NO.	C <sub>15</sub>	C <sub>16</sub>	C <sub>17</sub>	C <sub>18</sub>	C <sub>19</sub>	LENGTH	NO.	C <sub>15</sub>	C <sub>16</sub>	C <sub>17</sub>	C <sub>18</sub>	C <sub>19</sub>	LENGTH
3'	6'-2"	11'-9"	17'-5"	--	--	--	--	--	4'-6"	8'-7"	12'-9"	--	--	--	--	--	38	3'-10"	9"	7"	4'-0"	1'-0"	6'-7"	27	3'-10"	9"	9"	3'-10"	1'-0"	6'-7"
4'	6'-2"	11'-9"	17'-5"	23'-1"	--	--	--	--	4'-6"	8'-7"	12'-9"	16'-11"	--	--	--	--	49	4'-11"	10"	9"	5'-0"	1'-0"	7'-9"	35	4'-11"	10"	10"	10"	4'-11"	7'-9"
5'	6'-2"	11'-9"	17'-5"	23'-1"	28'-9"	--	--	--	4'-6"	8'-7"	12'-9"	16'-11"	21'-0"	--	--	--	60	5'-11"	10"	9"	6'-0"	1'-0"	8'-9"	43	5'-11"	10"	11"	5'-10"	1'-0"	8'-9"
6'	6'-2"	11'-9"	17'-5"	23'-1"	28'-9"	34'-5"	--	--	4'-6"	8'-7"	12'-9"	16'-11"	21'-0"	25'-2"	--	--	72	6'-11"	10"	8"	7'-1"	1'-0"	9'-9"	52	6'-11"	10"	10"	6'-11"	1'-0"	9'-9"
7'	6'-2"	11'-9"	17'-5"	23'-1"	28'-9"	34'-5"	40'-0"	--	4'-6"	8'-7"	12'-9"	16'-11"	21'-0"	25'-2"	29'-4"	--	83	8'-0"	11"	9"	8'-2"	1'-0"	10'-11"	60	8'-0"	11"	11"	8'-0"	1'-0"	10'-11"
8'	6'-2"	11'-9"	17'-5"	23'-1"	28'-9"	34'-5"	40'-0"	47'-3"	4'-6"	8'-7"	12'-9"	16'-11"	21'-0"	25'-2"	29'-4"	33'-5"	94	9'-0"	11"	10"	9'-1"	1'-1"	12'-1"	68	9'-0"	11"	11"	9'-0"	1'-1"	12'-1"

TABLE OF REINFORCEMENT BARS FOR MINIMUM "S" - ONE END										
S	H	Y(E) BARS 12-#5 (2)	R(E) BARS 6-#5 (2)	Z(E) BARS #4@12" (1)	S(E) BARS #4@12" (1)	T(E) BARS #4@12" (1)	P(E) BARS 8-#5 (3)	LENGTH	LENGTH	
≥ 9'	3'	11'-4"	19'-10"	10	5'-4"	20	6'-10"	10	3'-0"	6'-8"
≥ 9'	4'	11'-4"	22'-10"	10	5'-4"	23	6'-10"	10	3'-0"	7'-8"
≥ 5'	5'	6'-9"	21'-1"	6	5'-4"	21	6'-10"	6	3'-0"	8'-8"
≥ 6'	6'	7'-10"	25'-2"	7	5'-4"	25	6'-10"	7	3'-0"	9'-8"
≥ 7'	7'	9'-1"	29'-3"	8	5'-4"	30	6'-10"	8	3'-0"	10'-8"
≥ 8'	8'	10'-4"	33'-4"	9	5'-4"	34	6'-10"	9	3'-0"	11'-8"

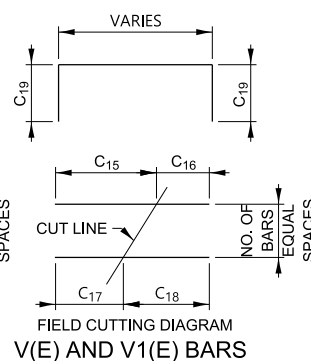
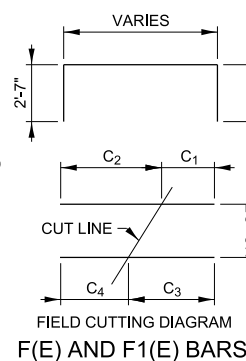
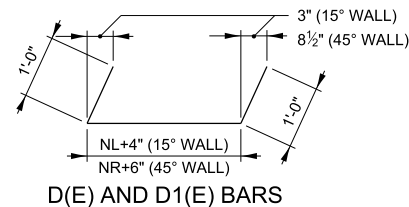
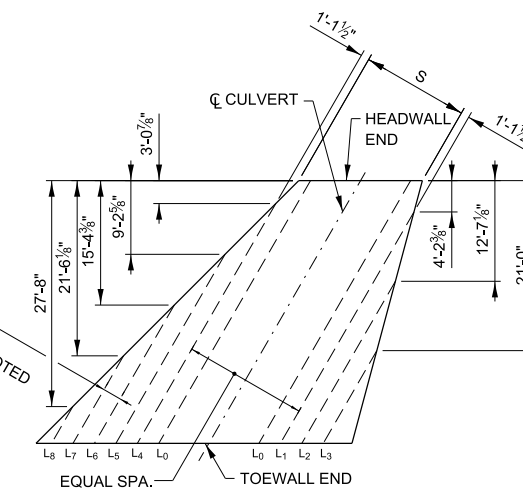
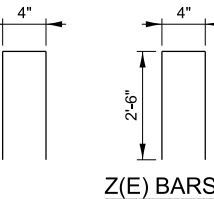
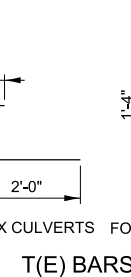
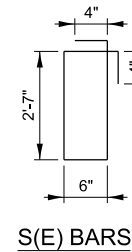
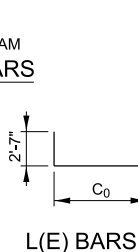
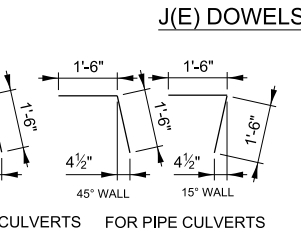
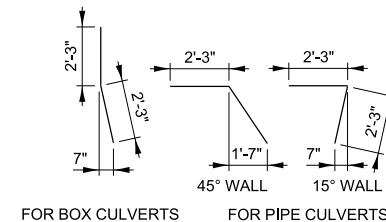
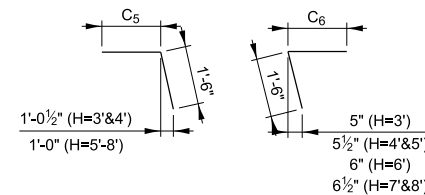

- NOTES FOR TABLES:
- THE NUMBER OF S(E), T(E) AND Z(E) BARS SHALL BE INCREASED BY 1 FOR EACH 1 FOOT OF INCREASE IN DIMENSION "W<sub>1</sub>".
  - THE LENGTH OF R(E) AND Y(E) BARS SHALL BE INCREASED BY 1'-1<sup>1</sup>/<sub>8</sub>" FOR EACH 1 FOOT OF INCREASE IN DIMENSION "S".
  - THE NUMBER OF P(E) BARS SHOWN ARE FOR SINGLE SPAN PIPES OR BOX CULVERTS. THIS NUMBER SHALL BE INCREASED BY 4 FOR EACH MULTIPLE OF PIPE OR BOX ADDED.
  - THIS DIMENSION SHALL BE INCREASED BY 1'-1<sup>1</sup>/<sub>8</sub>" INCHES FOR EACH 1 FOOT INCREASE IN DIMENSION "S".
  - 2 BARS FOR 15° WALL, 2 BARS FOR 45° WALL.
  - THE LENGTH OF THIS BAR INCLUDES ONE 1'-6" MINIMUM LAP.

APPROVED BY: *Paul Kovacs*  
 CHIEF ENGINEERING OFFICER  
 DATE: 03/01/2022

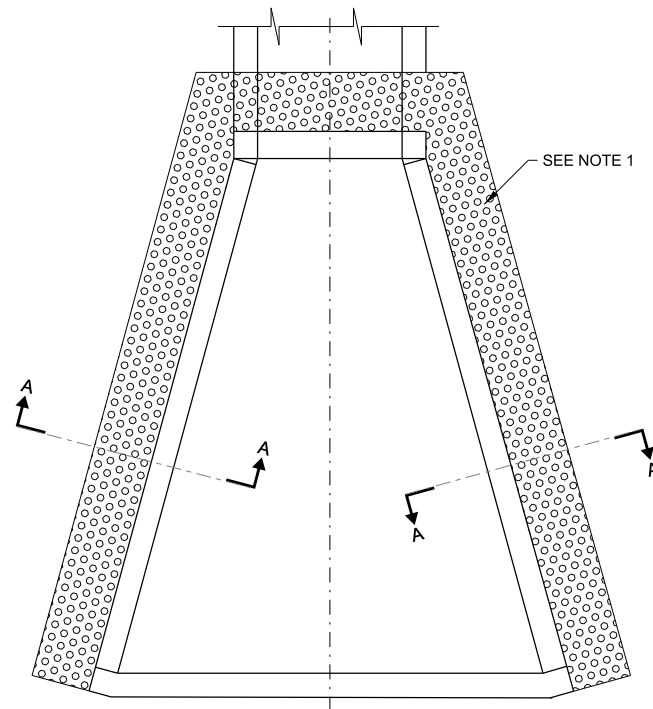

PLAN-0° SKEW, H≤4'

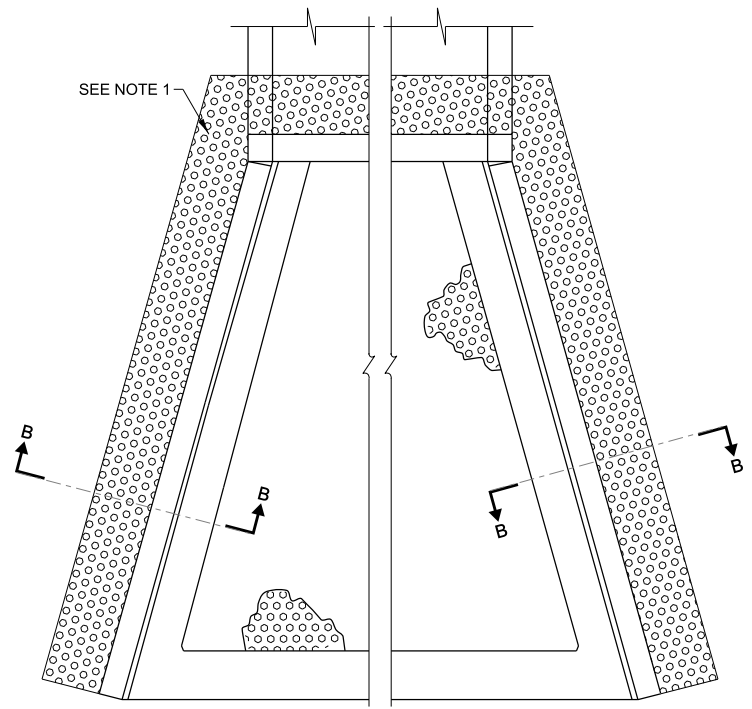

PLAN-0° SKEW, H≤8'

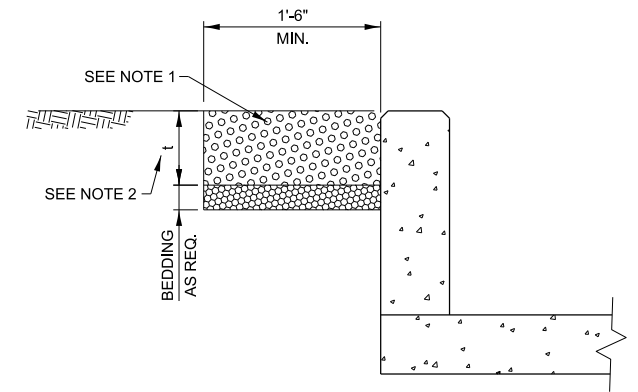

SECTION A-A

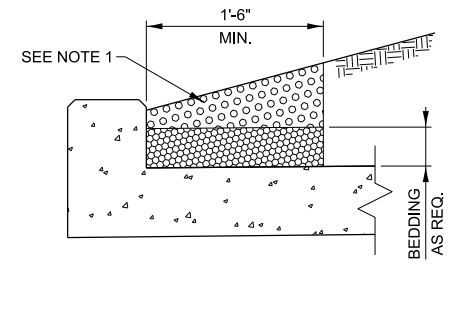

SECTION AT HEADWALL

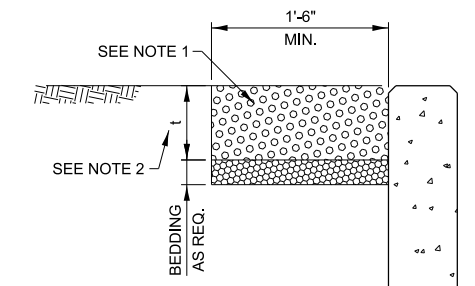

SECTION B-B

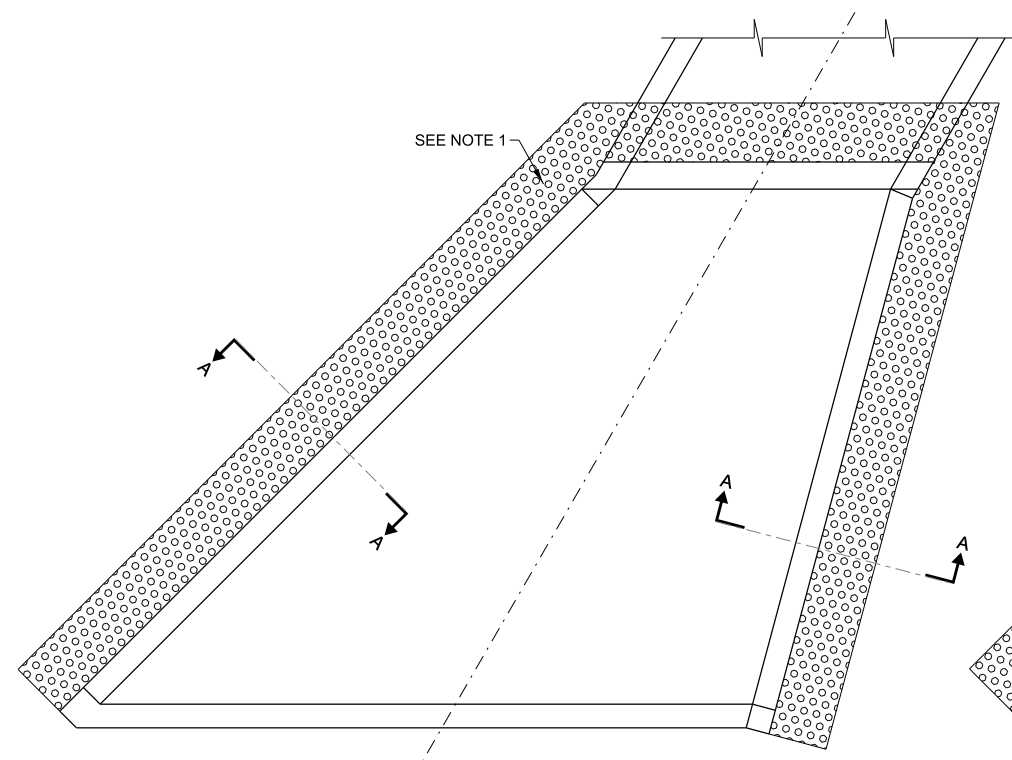
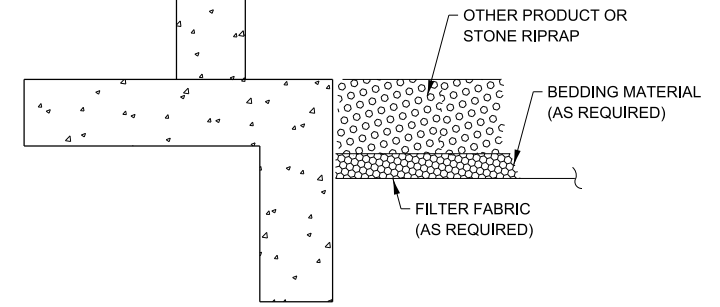

PLAN-SKEW, H≤4'

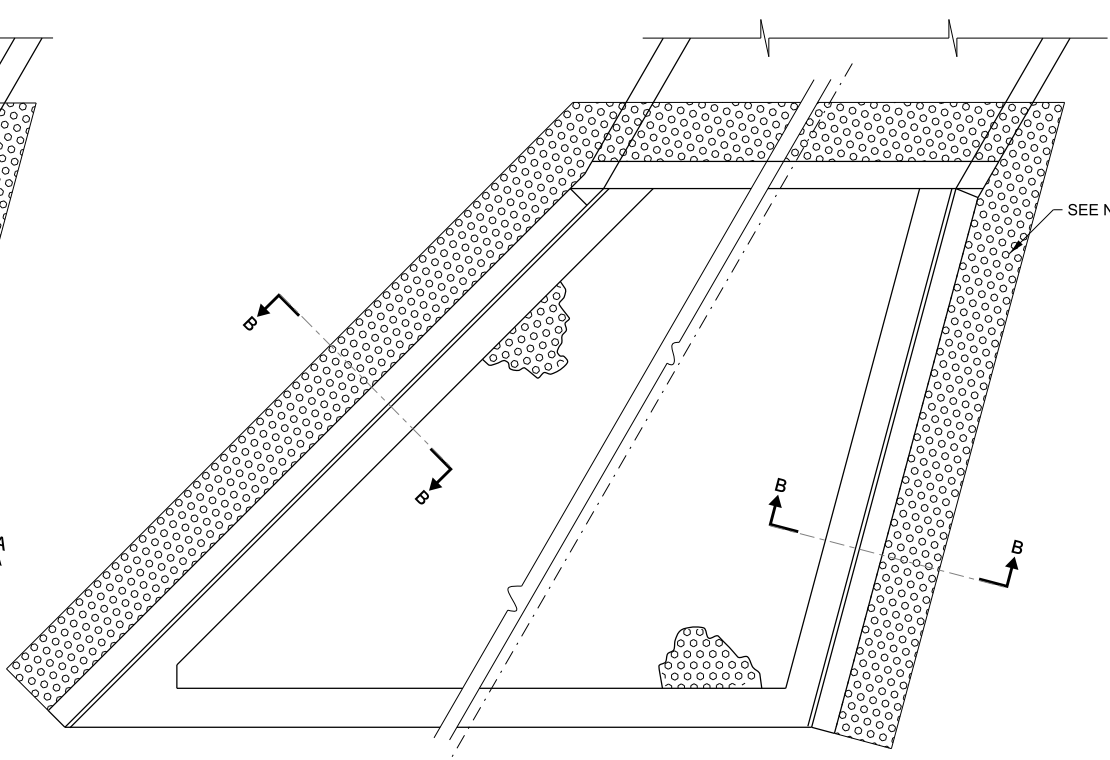

PLAN-SKEW, H≤8'

**NOTES:**

1. THE PREFERRED METHOD FOR ACHIEVING EROSION PROTECTION AT END SECTIONS SHOULD BE THROUGH THE USE OF PRODUCTS THAT PROMOTE REVEGETATION WITHIN THE AREA OF CONCERN.
2. THICKNESS "t" WILL BE DETERMINED BY THE MANUFACTURER'S RECOMMENDATION FOR THE PRODUCT USED.
3. EROSION PROTECTION PLACEMENT SHALL BE INSTALLED FLUSH WITH ADJACENT GRADE.
4. FOR USE WITH STANDARDS B10 TO B18.
5. STONE RIPRAP SHALL BE IN ACCORDANCE WITH THE STANDARD SPECIFICATIONS AND DRAINAGE DESIGN MANUAL.



**EROSION PROTECTION**

REVISIONS	
DATE	DESCRIPTION
03-11-2015	REVISED NOTES
03-01-2010	REVISED EROSION PROTECTION AND NOTES

APPROVED BY: *Paul Kovacs*  
 CHIEF ENGINEERING OFFICER      DATE: 03/01/2015

**DIMENSIONS AND QUANTITIES IN TWO WINGWALLS 1:4 SLOPE**

CULVERT HEIGHT	DIMENSIONS							NO. OF SPACES			CONCRETE CLASS SI C.Y. *	REINF. BARS * (POUND)
	H	L	S	T	U	A	E	B	C	D		
36"	3'-8"	14'-0"	14'-5½"	2"	2'-8"	2'-2"	2'-2"	-	4	-	1.33	188
42"	4'-3"	16'-4"	16'-10"	2"	3'-2"	2'-8"	2'-2"	4	-	-	1.78	259
48"	4'-9"	18'-4"	18'-10¾"	2"	3'-2"	2'-2"	2'-2"	-	6	-	2.23	304
54"	5'-3"	20'-4"	20'-11½"	2"	3'-6"	2'-2"	2'-2"	4	2	-	2.72	379
60"	5'-10"	22'-8"	23'-4¾"	2"	3'-6"	2'-2"	2'-2"	-	8	-	3.36	468

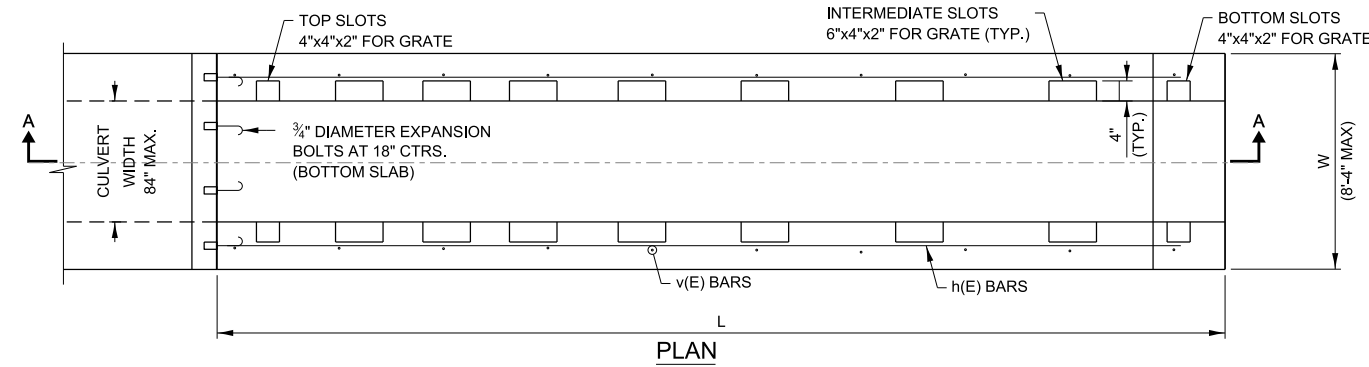

**TABLE OF BARS IN ONE WINGWALL 1:4 SLOPE**

NO. 4 REINFORCEMENT BARS						
CULVERT HEIGHT	MARK(E)	TYPE	NO. REQ'D	LENGTH	a	b
36"	h 36	STR.	4	13'-8"	2'-0"	3'-6"
	3/4" EXP BLT	-	3	-		
	v 36	2	7	5'-6"		
42"	h 42	STR.	5	16'-0"	1'-11"	4'-1"
	3/4" EXP BLT	-	4	-		
	v 42	2	10	6'-0"		
48"	h 48	STR.	5	18'-0"	1'-10"	4'-7"
	3/4" EXP BLT	-	4	-		
	v 48	2	13	6'-5"		
54"	h 54	STR.	6	20'-0"	1'-10"	5'-1"
	3/4" EXP BLT	-	4	-		
	v 54	2	15	6'-11"		
60"	h 60	STR.	7	22'-4"	1'-11"	5'-8"
	3/4" EXP BLT	-	5	-		
	v 60	2	17	7'-7"		
	x 60	1	23	3'-2"	2'-2"	1'-0"

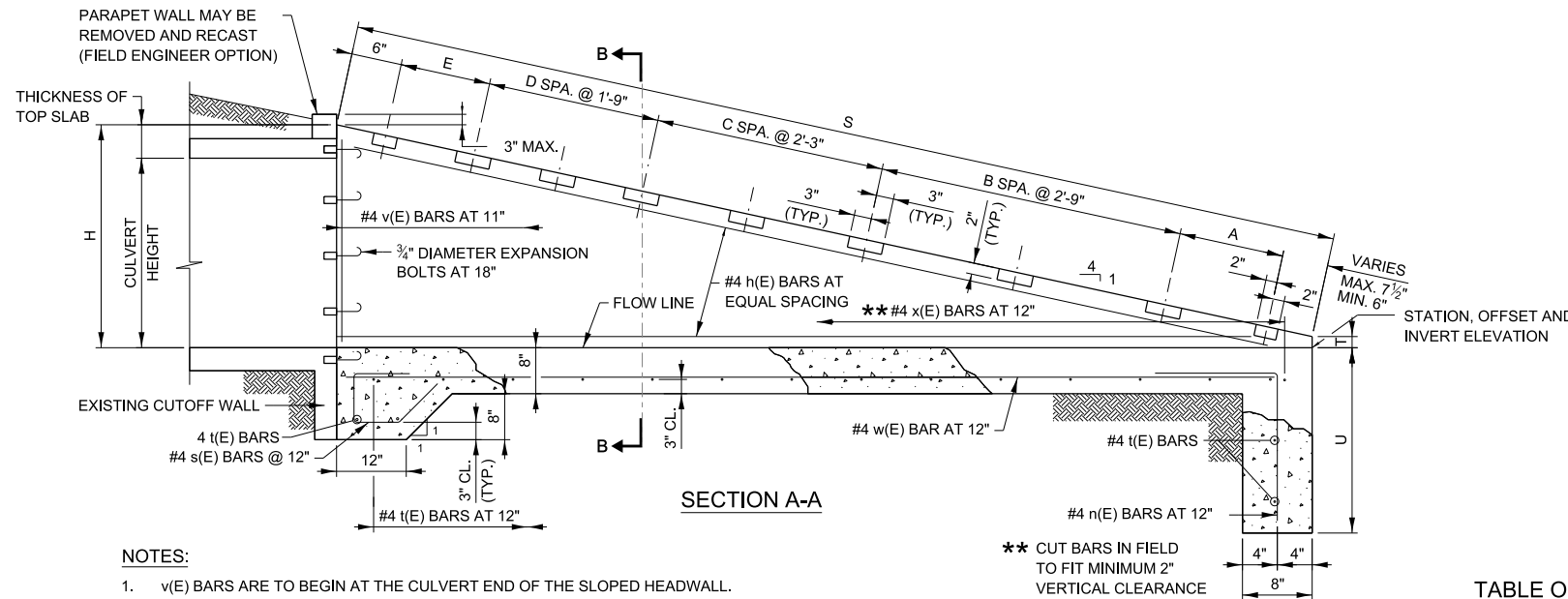

**NOTES:**

- v(E) BARS ARE TO BEGIN AT THE CULVERT END OF THE SLOPED HEADWALL.
- ¾" DIAMETER EXPANSION BOLTS SHALL CONSIST OF SELF DRILLING EXPANSION SHIELDS AND ¾" DIAMETER HOOKED BOLTS. HOOKED BOLTS SHALL EXTEND A MINIMUM OF 9" INTO NEW CONCRETE WITH ANCHORAGE IN ACCORDANCE WITH THE STANDARD SPECIFICATIONS. MINIMUM CERTIFIED PROOF LOAD = 4,080 LBS.

**TABLE OF BARS IN SLAB 1:4 SLOPE (PER FT. OF FLOOR SLAB WIDTH)**

NO. 4 REINFORCEMENT BARS								
CULVERT HEIGHT	MARK(E)	TYPE	NO. REQ'D	LENGTH	a	b	REINF. BAR LB. *	CONCRETE CLASS SI (C.Y.) *
36"	n 36	1	1	4'-1"	2'-1"	2'-0"	27	.45
	w 36	STR.	1	13'-5"				
	t 36	STR.	18	W-(0'-4")				
	¾" EXP BLT	-	0.67	-				
42"	n 42	1	1	4'-7"	2'-7"	2'-0"	32	.53
	w 42	STR.	1	15'-9"				
	t 42	STR.	20	W-(0'-4")				
	¾" EXP BLT	-	0.67	-				
48"	n 48	1	1	4'-7"	2'-7"	2'-0"	33	.58
	w 48	STR.	1	17'-9"				
	t 48	STR.	22	W-(0'-4")				
	¾" EXP BLT	-	0.67	-				
54"	n 54	1	1	4'-11"	2'-11"	2'-0"	37	.64
	w 54	STR.	1	19'-9"				
	t 54	STR.	24	W-(0'-4")				
	¾" EXP BLT	-	0.67	-				
60"	n 60	1	1	4'-11"	2'-11"	2'-0"	39	.70
	w 60	STR.	1	22'-1"				
	t 60	STR.	26	W-(0'-4")				
	¾" EXP BLT	-	0.67	-				
	s 60	3	1	3'-7"				

**NOTES:**

- TYPE 2 "v(E)" BARS SHALL BE ORDERED FULL LENGTH AND CUT IN THE FIELD. THE REMAINING PORTION OF THE "v(E)" BARS SHALL BE USED IN THE OTHER WALL.
- THE LONG LEG OF THE "n(E)" BAR SHALL BE VERTICAL.
- SEE STANDARD B23 FOR GRATING DETAILS.

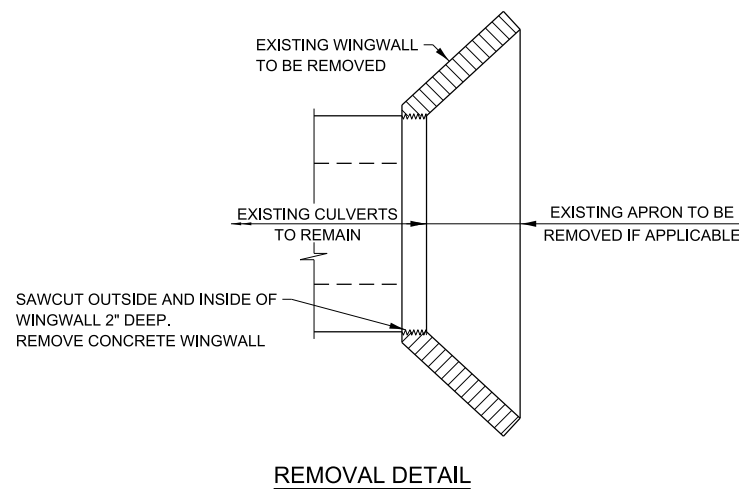

**GENERAL NOTES:**

- ALL EXPOSED CONCRETE EDGES SHALL HAVE A ¾" X 45° CHAMFER. CHAMFER ON VERTICAL EDGES SHALL BE CONTINUED A MINIMUM OF ONE FOOT BELOW FINISHED GROUND LEVEL.
- COVER FROM THE FACE OF CONCRETE TO FACE OF REINFORCEMENT BARS SHALL BE 2" UNLESS OTHERWISE SHOWN.
- CONCRETE QUANTITIES SHOWN ARE FOR REINFORCED CONCRETE BOX CULVERT HEADWALLS.
- PAY ITEMS ARE IDENTIFIED BY AN ASTERISK (\*).
- ALL SLOPES ARE EXPRESSED AS UNITS OF VERTICAL DISPLACEMENT TO UNITS OF HORIZONTAL DISPLACEMENT (V:H).
- ALL REINFORCEMENT BARS SHALL BE EPOXY COATED (E).

REVISIONS	
DATE	DESCRIPTION
03-01-2022	REVISED HEADWALL TO WINGWALL IN REMOVAL DETAIL AND REVISED REBAR TABLE
03-31-2016	STATION, OFFSET & INVERT ELEVATION MOVED



**HEADWALL TYPE IV CONCRETE BOX CULVERT ≤ 84" WIDTH**

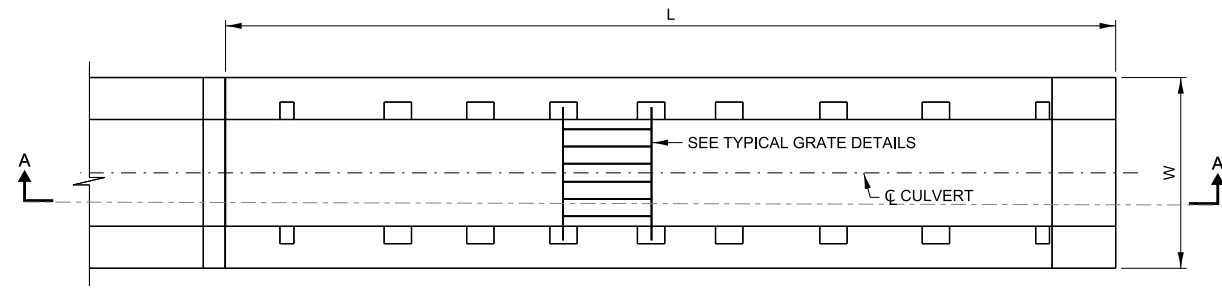

PLAN VIEW (NO SKEW)  
SINGLE BOX CULVERT ≤ 84" WIDE

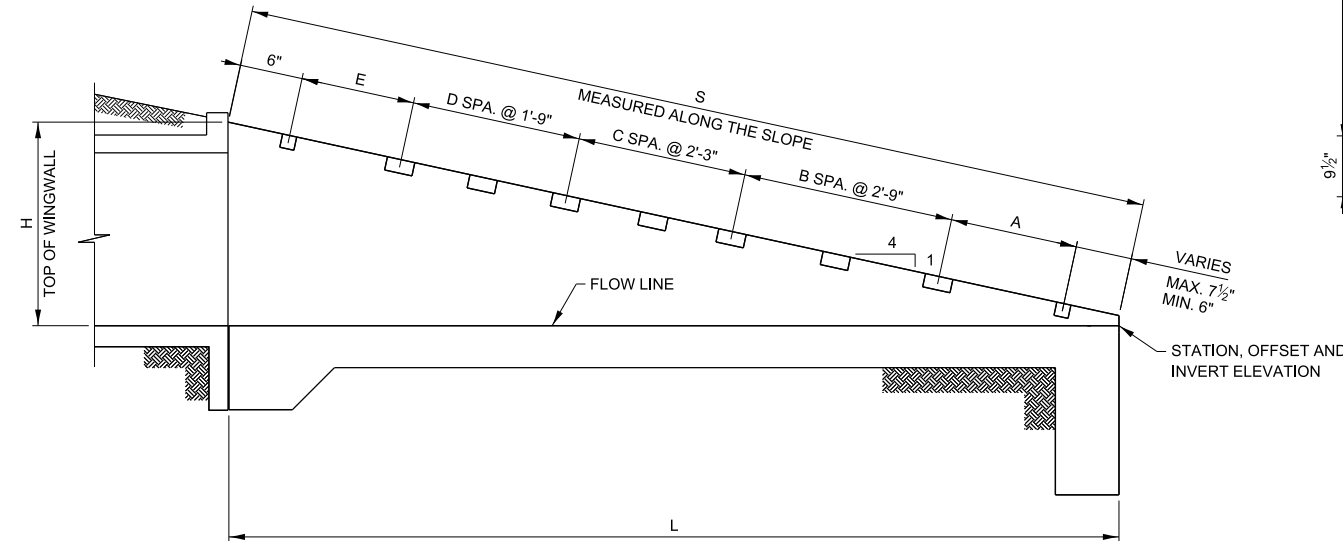

SECTION A-A  
END TREATMENT - MULTIPLE OR SINGLE CELL  
BOX CULVERT

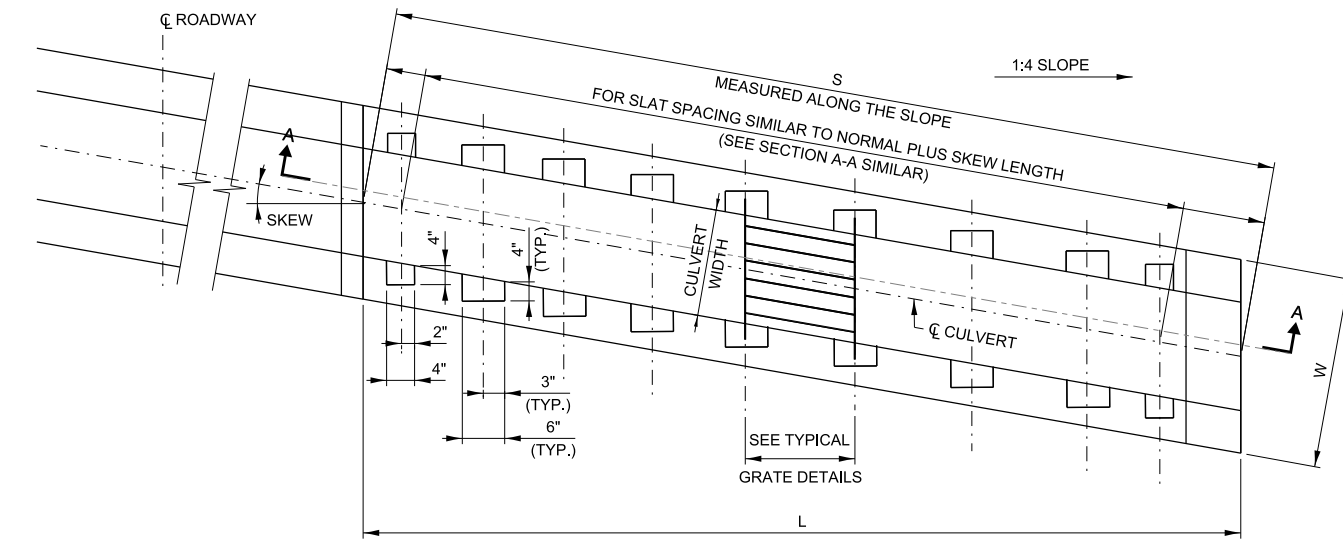

NOTE:  
REINFORCEMENT BARS AND GRATE SPACING ARE  
SIMILAR TO BOX CULVERT AT NORMAL (NO SKEW).

PLAN VIEW (WITH SKEW)  
SINGLE BOX CULVERT ≤ 84" WIDE

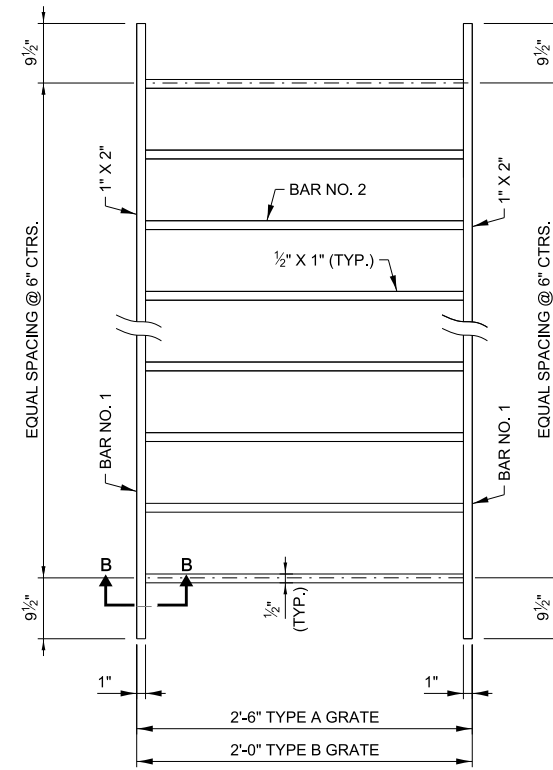

TYPICAL GRATE  
(NO SKEW)

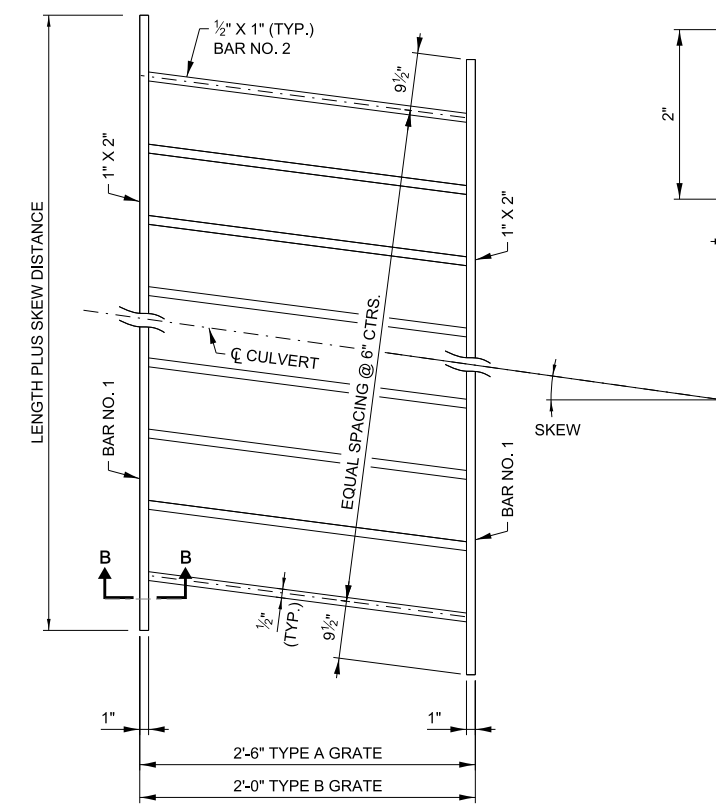

GRATE  
(WITH SKEW)

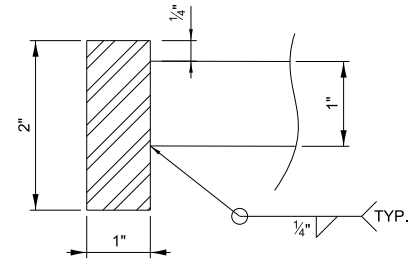

SECTION B-B

GRATING DIMENSIONS AND QUANTITIES  
IN ONE HEADWALL TYPE IV  
BASED ON A 1 FOOT WIDTH, 1:4 SLOPE, AND NO SKEW

CULVERT HEIGHT	GRATES		BARS FOR ONE GRATE				GRATING (LBS.) * EACH GRATE
	NUMBER REQUIRED	TYPE REQ'D	BAR NO. 1		BAR NO. 2		
			BARS REQ'D	LENGTH	BARS REQ'D	LENGTH	
36"	6	B	2	W-0.75	W-1.33 0.5 -1	1'-10"	19.9W - 21.6
42"	5	A	2	W-0.75	W-1.33 0.5 -1	2'-4"	21.5W - 24.7
	1	B	2	W-0.75	W-1.33 0.5 -1	1'-10"	19.9W - 21.6
48"	8	B	2	W-0.75	W-1.33 0.5 -1	1'-10"	19.9W - 21.6
	4	A	2	W-0.75	W-1.33 0.5 -1	2'-4"	21.5W - 24.7
54"	4	B	2	W-0.75	W-1.33 0.5 -1	1'-10"	19.9W - 21.6
	4	A	2	W-0.75	W-1.33 0.5 -1	2'-4"	21.5W - 24.7
60"	10	B	2	W-0.75	W-1.33 0.5 -1	1'-10"	19.9W - 21.6

GENERAL NOTES:

- ALL TABLE DIMENSIONS AND QUANTITIES ARE FOR SINGLE BOX CULVERT HEADWALLS. TO ADAPT ANY OF THESE TABLES FOR DOUBLE BOX CULVERTS, DOUBLE THE NUMBER OF GRATES REQUIRED AND ADD AN ADDITIONAL WALL. (WALL THICKNESS SHALL BE SAME AS THE CENTER WALL THICKNESS OF THE BOX CULVERT).
- FOR QUANTITY CALCULATIONS DIMENSION "W" SHALL BE MEASURED IN FEET.
- QUANTITIES FOR SKEWED HEADWALLS NOT SHOWN.
- PAY ITEMS ARE IDENTIFIED BY AN ASTERISK (\*).
- ALL SLOPES ARE EXPRESSED AS UNITS OF VERTICAL DISPLACEMENT TO UNITS OF HORIZONTAL DISPLACEMENT (V:H).
- GRATING IS DESIGNED FOR A TRANSVERSING LOAD OF 1,800 POUNDS AT YIELD.

DIMENSIONS "S" FOR SLOPE 1:4  
FOR VARIOUS CULVERT SIZES AND SKEWS

CULVERT HEIGHT	NO SKEW	≤ 10°	10° ≤ 20°	20° ≤ 30°
36"	14'-5 1/8"	14'-7 3/4"	15'-4 1/4"	16'-8"
42"	16'-10"	17'-1"	17'-11"	19'-5 1/4"
48"	18'-10 3/4"	19'-2 1/4"	20'-1 1/4"	21'-10"
54"	20'-11 1/2"	21'-3 3/8"	22'-3 3/8"	24'-2 3/8"
60"	23'-4 3/8"	23'-8 3/4"	24'-10 3/8"	26'-11 3/4"

REVISIONS	
DATE	DESCRIPTION
03-01-2022	REVISED BAR NO. 1 THICKNESS AND WEIGHT OF HEADWALL GRATES
03-31-2016	STATION, OFFSET AND INVERT ELEVATION MOVED
02-07-2012	DELETED SECTION FROM PLAN VIEW

**GRATING FOR HEADWALL TYPE IV BOX CULVERT ≤ 84" WIDE**

VERSION: 2022-03      STANDARD: B21-04      SHEET: 1 OF 1

APPROVED BY: *Paul Kovacs*  
CHIEF ENGINEERING OFFICER      DATE: 03/01/2022

**DIMENSIONS AND QUANTITIES IN TWO WINGWALLS 1:4 SLOPE**

PIPE-ARCH ELLIPTICAL PIPE (SPAN ≤ 77")	CIRCULAR PIPE (DIAMETER)	DIMENSIONS								NO. OF SPACES			CONCRETE CLASS SI CY. *	REINF. BAR * (POUND)
		H	L	S	T	U	A	E	B	C	D			
RISE ≤ 30"		3'-2"	12'-0"	12'-4½"	2"	2'-8"	2'-2"	2'-2"	-	3	-	.98	151	
RISE ≤ 36"		3'-8"	14'-0"	14'-5½"	2"	2'-8"	2'-2"	2'-2"	-	4	-	1.33	188	
RISE ≤ 42"		4'-3"	16'-4"	16'-10"	2"	3'-2"	2'-8"	2'-2"	4	-	-	1.78	251	
RISE ≤ 48"		4'-9"	18'-4"	18'-10¾"	2"	3'-2"	2'-2"	2'-2"	-	6	-	2.23	295	
RISE ≤ 54"	54"	5'-3"	20'-4"	20'-11½"	2"	3'-6"	2'-2"	2'-2"	4	2	-	2.72	370	
RISE ≤ 60"	60"	5'-10"	22'-8"	23'-4¾"	2"	3'-6"	2'-2"	2'-2"	-	8	-	3.36	428	
	66"	6'-4"	24'-8"	25'-5½"	2"	3'-6"	2'-2"	2'-2"	4	4	-	3.96	517	

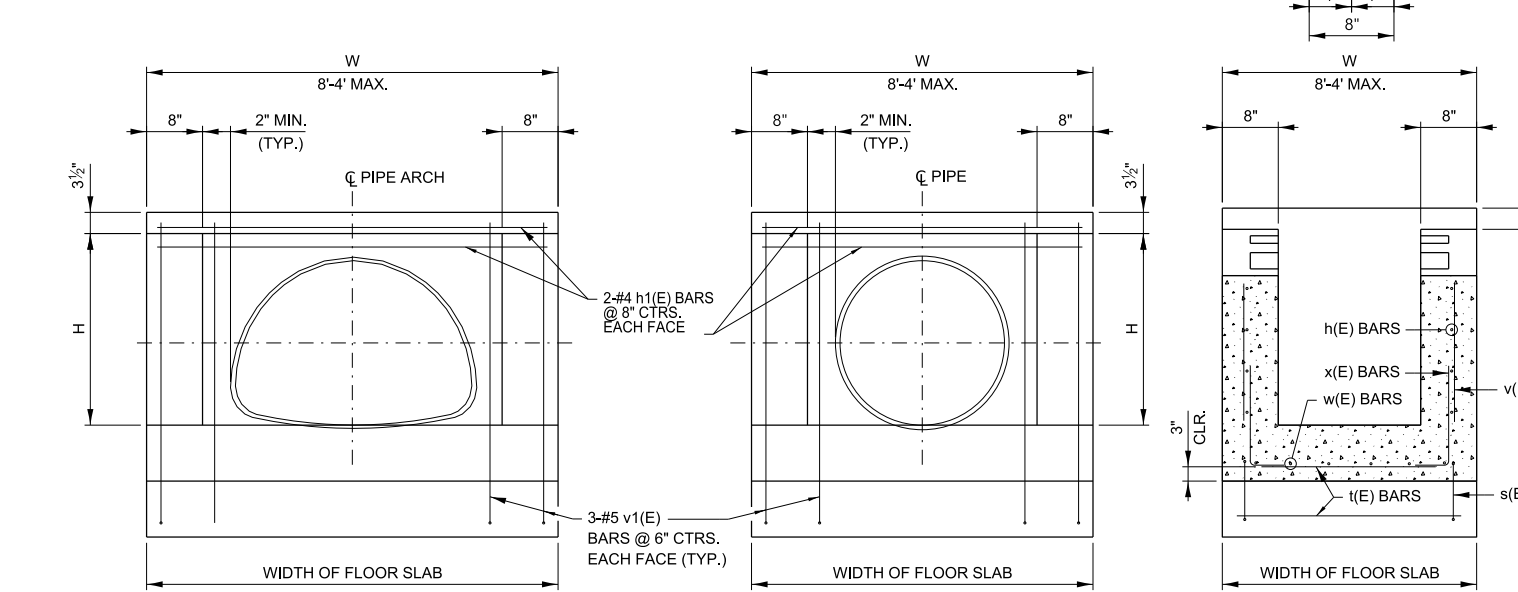
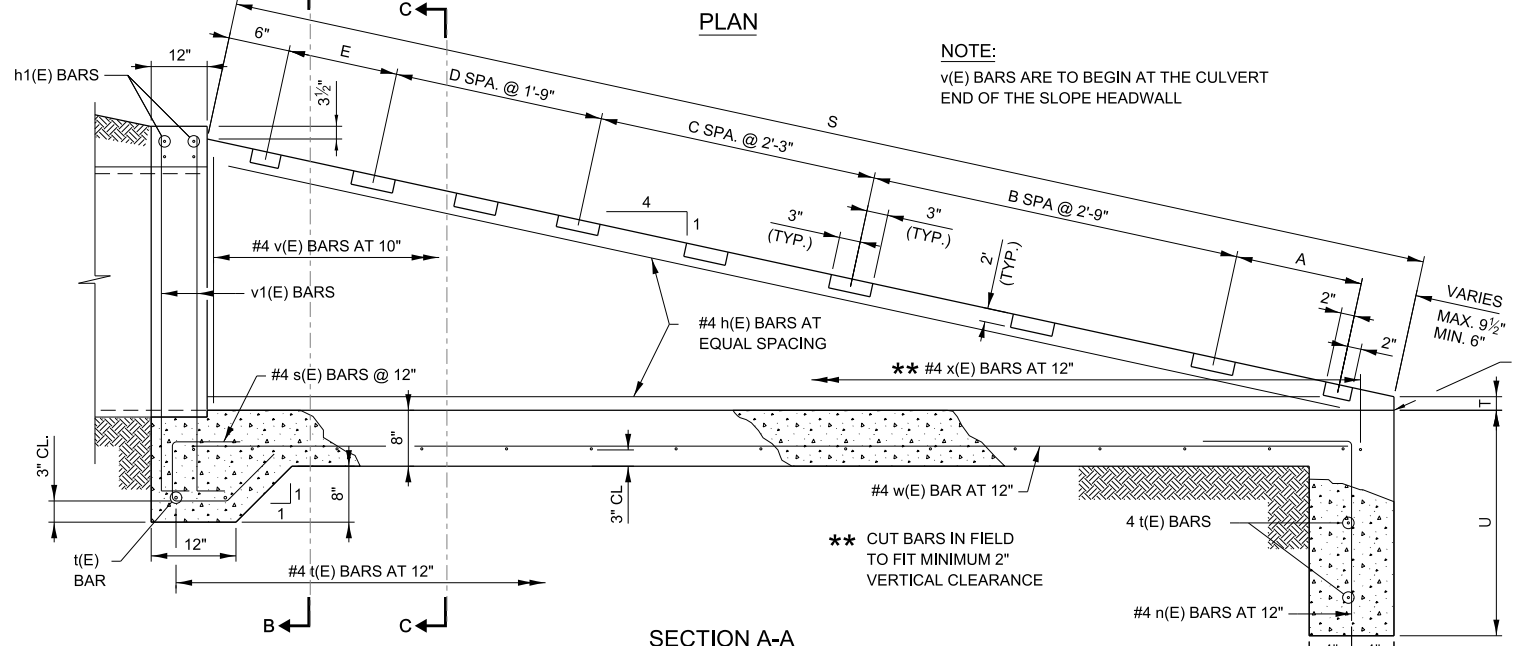
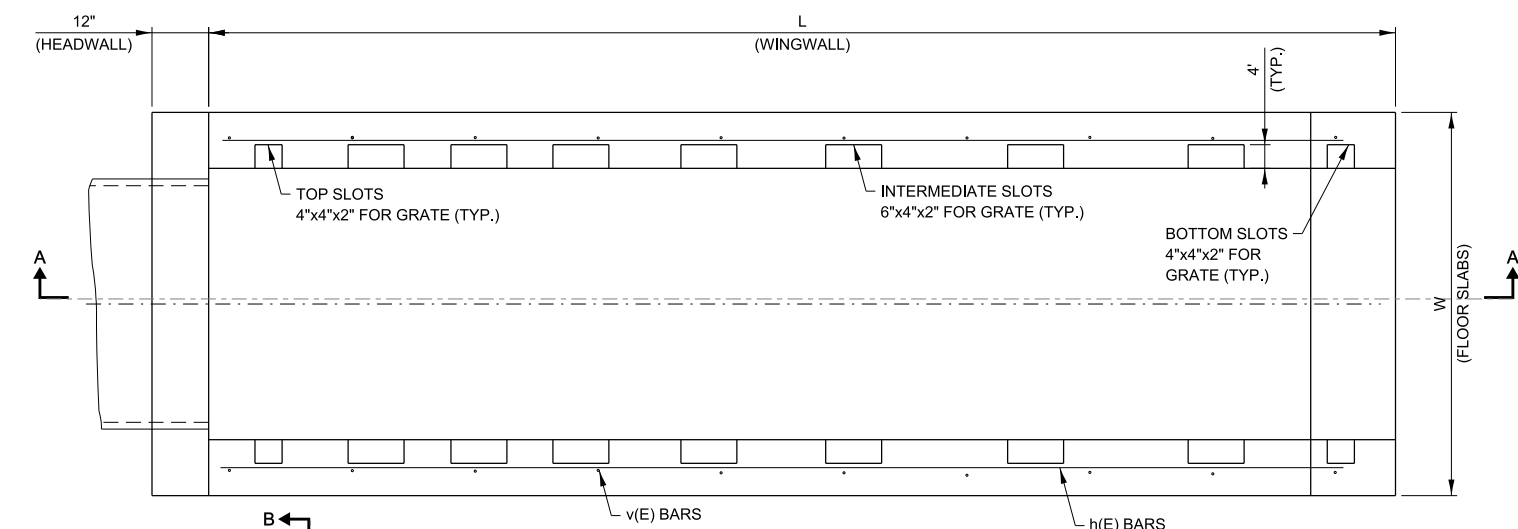
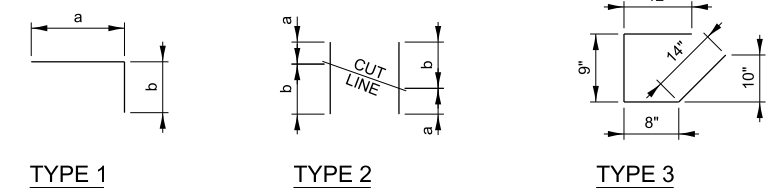

APPROVED BY: *Paul Kovacs*  
CHIEF ENGINEERING OFFICER  
DATE: 03/01/2022

**TABLE OF BARS  
IN ONE WINGWALL 1:4 SLOPE**

NO. 4 REINFORCEMENT BARS						
H	MARK(E)	TYPE	NO. REQ'D	LENGTH	a	b
3'-2"	H 30	STR.	4	11'-8"		
	V 30	2	6	5'-0"	2'-0"	3'-0"
	X 30	1	13	3'-2"	2'-2"	1'-0"
3'-8"	H 36	STR.	4	13'-8"		
	V 36	2	8	5'-6"	2'-0"	3'-6"
	X 36	1	15	3'-2"	2'-2"	1'-0"
4'-3"	H 42	STR.	5	16'-0"		
	V 42	2	11	6'-0"	1'-11"	4'-1"
	X 42	1	17	3'-2"	2'-2"	1'-0"
4'-9"	H 48	STR.	5	18'-0"		
	V 48	2	14	6'-5"	1'-10"	4'-7"
	X 48	1	19	3'-2"	2'-2"	1'-0"
5'-3"	H 54	STR.	6	20'-0"		
	V 54	2	16	6'-11"	1'-10"	5'-1"
	X 54	1	21	3'-2"	2'-2"	1'-0"
5'-10"	H 60	STR.	6	22'-4"		
	V 60	2	18	7'-7"	1'-11"	5'-8"
	X 60	1	23	3'-2"	2'-2"	1'-0"
6'-4"	H 66	STR.	7	24'-4"		
	V 66	2	21	8'-1"	1'-11"	6'-2"
	X 66	1	25	3'-2"	2'-2"	1'-0"

**TABLE OF BARS IN SLAB 1:4 SLOPE  
(PER FT. OF FLOOR SLAB WIDTH)**

NO. 4 REINFORCEMENT BARS								
H	MARK(E)	TYPE	NO. REQ'D	LENGTH	a	b	REINF. BARS (POUND) *	CONCRETE CLASS SI (C.Y.) *
3'-2"	h 131	STR.	4	W-(0'-4")			52	.38
	v 131	1	8	5'-0"	4'-4"	8"		
	n 30	1	1	4'-1"	2'-1"	2'-0"		
3'-8"	w 30	STR.	15	W-(0'-4")			58	.43
	t 30	STR.	3	3'-7"	4'-10"	8"		
	s 30	1	1	4'-1"	2'-1"	2'-0"		
4'-3"	h 142	STR.	4	W-(0'-4")			65	.50
	v 142	1	8	6'-1"	5'-5"	8"		
	n 42	1	1	4'-7"	2'-7"	2'-0"		
4'-9"	w 42	STR.	21	W-(0'-4")			70	.55
	t 42	STR.	3	3'-7"	5'-11"	8"		
	s 42	1	1	18'-5"	2'-7"	2'-0"		
5'-3"	h 154	STR.	4	W-(0'-4")			76	.60
	v 154	1	8	7'-1"	6'-5"	8"		
	n 54	1	1	4'-11"	2'-11"	2'-0"		
5'-10"	w 54	STR.	25	W-(0'-4")			82	.66
	t 54	STR.	3	3'-7"	7'-0"	8"		
	s 54	1	1	20'-5"	2'-11"	2'-0"		
6'-4"	h 166	STR.	4	W-(0'-4")			87	.71
	v 166	1	8	8'-2"	7'-6"	8"		
	n 66	1	1	4'-11"	2'-11"	2'-0"		

**GENERAL NOTES:**

- TYPE 2 "v(E)" BARS SHALL BE ORDERED FULL LENGTH AND CUT IN THE FIELD. THE REMAINING PORTION OF THE "v(E)" BARS SHALL BE USED IN THE OTHER WALL.
- THE LONG LEG OF THE "n(E)" BARS SHALL BE VERTICAL.
- PAY ITEMS ARE IDENTIFIED BY AN ASTERISK (\*).
- SEE STANDARD B23 FOR GRATING DETAILS.
- ALL CONCRETE SHALL BE CLASS SI.
- ALL SLOPES ARE EXPRESSED AS UNITS OF VERTICAL DISPLACEMENT TO UNITS OF HORIZONTAL DISPLACEMENT (V:H).
- ALL REINFORCEMENT BARS SHALL BE EPOXY COATED (E).

REVISIONS	
DATE	DESCRIPTION
03-01-2022	REVISED HEADWALL THICKNESS, REBAG SPACING AND REBAR TABLE
03-31-2016	STATION, OFFSET AND INVERT ELEVATION
03-11-2015	REVISED NOTES



**HEADWALL TYPE IV  
METAL PIPE & PIPE-ARCH  
CULVERTS**

VERSION: 2022-03 STANDARD: B22-05 SHEET: 1 OF 1

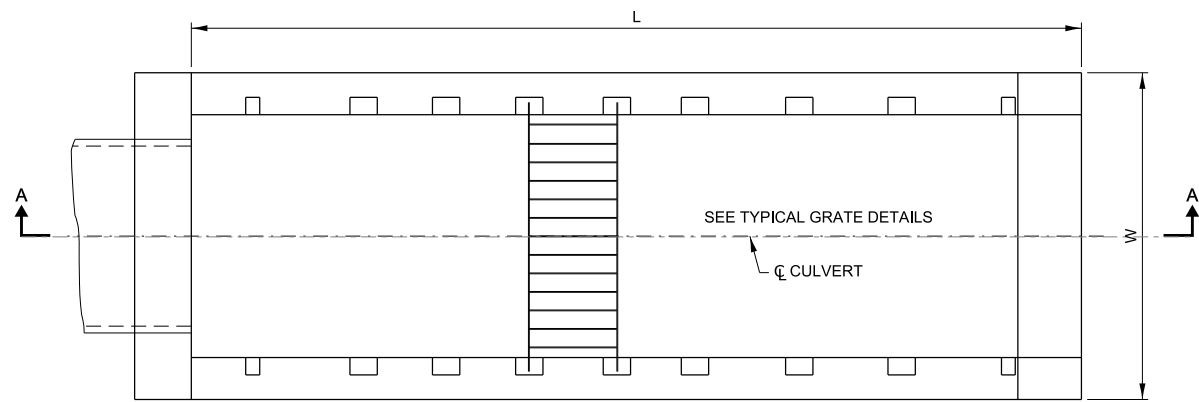

PLAN VIEW (NO SKEW)  
SINGLE BOX CULVERT ≤ 84" WIDE

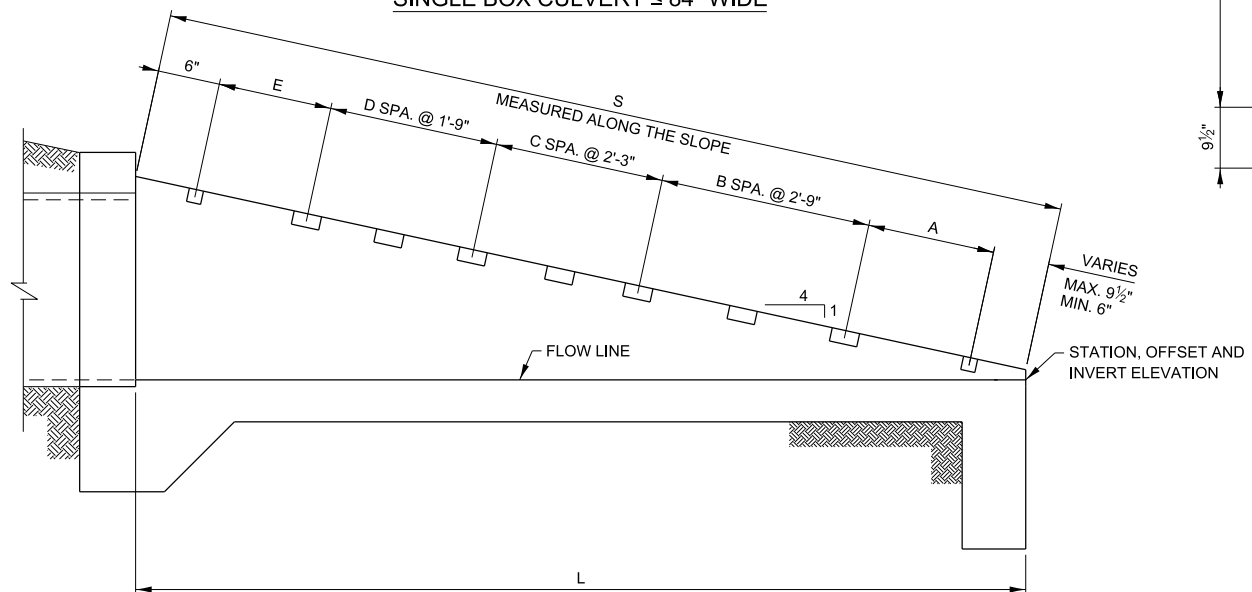

SECTION A-A  
END TREATMENT - MULTIPLE OR SINGLE CELL  
BOX CULVERT

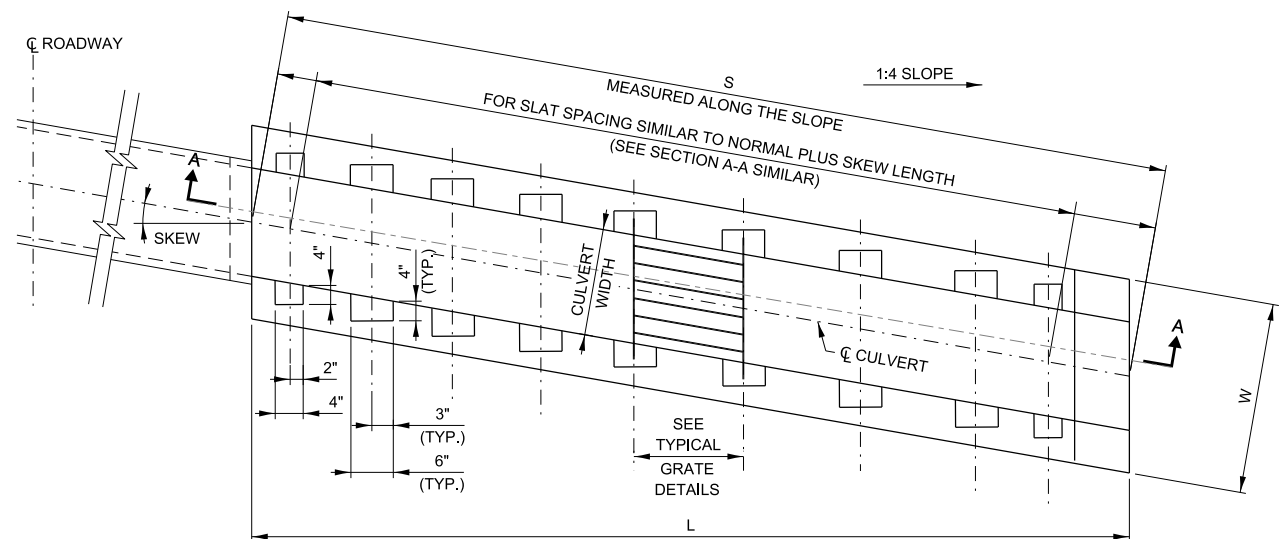

PLAN VIEW (WITH SKEW)

NOTE:  
REINFORCEMENT BARS AND GRATE SPACING ARE  
SIMILAR TO BOX CULVERT AT NORMAL (NO SKEW).

APPROVED BY: *Paul Kovacs*  
CHIEF ENGINEERING OFFICER  
DATE: 03/01/2022

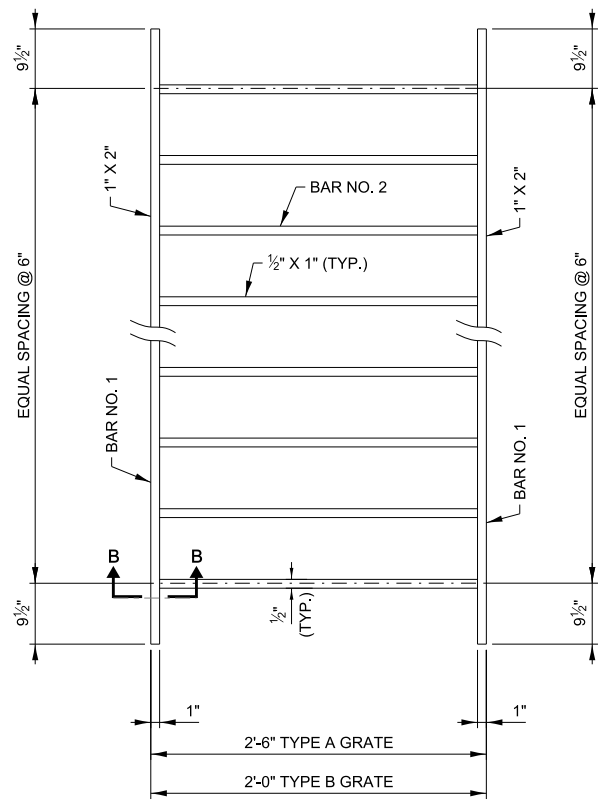

GRATE DETAILS  
(WITH NO SKEW)

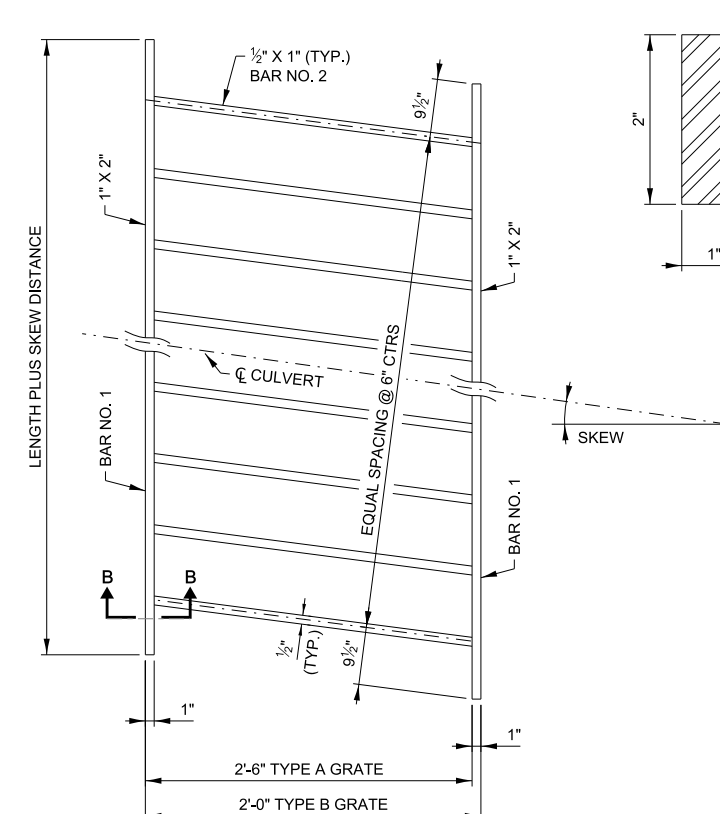

GRATE DETAILS  
(WITH SKEW)

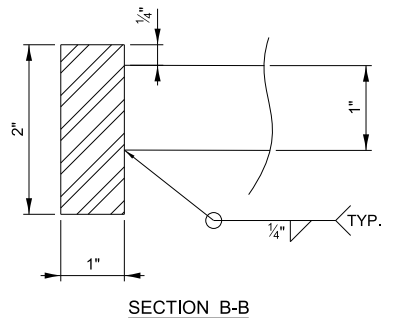

SECTION B-B

GRATING DIMENSIONS AND QUANTITIES IN ONE HEADWALL TYPE IV  
BASED ON A 1 FOOT WIDTH, 1:4 SLOPE AND SKEW

H	GRATES		BARS FOR ONE GRATE				GRATING (POUND) *
	NUMBER REQUIRED	TYPE REQ'D.	BAR NO. 1 BARS REQ'D.	LENGTH	BAR NO. 2 BARS REQ'D.	LENGTH	
3'-2"	5	B	2	W-75	W-1.33 0.5	1'-10"	19.9W - 21.6
3'-8"	6	B	2	W-75	W-1.33 0.5	1'-10"	19.9W - 21.6
4'-3"	5	A	2	W-75	W-1.33 0.5	2'-4"	21.5W - 24.7
4'-9"	8	B	2	W-75	W-1.33 0.5	1'-10"	19.9W - 21.6
5'-3"	4	A	2	W-75	W-1.33 0.5	2'-4"	21.5W - 24.7
5'-10"	10	B	2	W-75	W-1.33 0.5	1'-10"	19.9W - 21.6
6'-4"	4	A	2	W-75	W-1.33 0.5	2'-4"	21.5W - 24.7
	6	B	2	W-75	W-1.33 0.5	1'-10"	19.9W - 21.6

DIMENSIONS "S" FOR SLOPE 1:4  
FOR VARIOUS CULVERT SIZES AND SKEWS

H	NO SKEW	≤ 10°	10° ≤ 20°	20° ≤ 30°
3'-2"	12'-4 1/2"	12'-6 3/4"	13'-2"	14'-3 3/8"
3'-8"	14'-5 1/4"	14'-7 3/4"	15'-4 1/4"	16'-8"
4'-3"	16'-10"	17'-1"	17'-11"	19'-5 1/4"
4'-9"	18'-10 3/4"	19'-2 1/4"	20'-1 1/4"	21'-10"
5'-3"	20'-11 1/2"	21'-3 3/8"	22'-3 5/8"	24'-2 3/4"
5'-10"	23'-4 3/8"	23'-8 3/4"	24'-10 3/8"	26'-11 3/4"
6'-4"	25'-5 1/8"	25'-9 3/4"	27'-0 5/8"	29'-4 1/4"

- GENERAL NOTES:
- ALL TABLE DIMENSIONS AND QUANTITIES ARE FOR SINGLE CULVERT HEADWALLS. TO ADAPT ANY OF THESE TABLES FOR DOUBLE CULVERTS, DOUBLE THE NUMBER OF GRATES REQUIRED AND ADD AN ADDITIONAL WALL. (WALL THICKNESS SHALL BE SAME AS THE CENTER WALL THICKNESS OF THE CULVERT.)
  - FOR QUANTITY CALCULATIONS DIMENSION "W" SHALL BE MEASURED IN FEET.
  - QUANTITIES FOR SKEWED HEADWALLS NOT SHOWN.
  - PAY ITEMS ARE IDENTIFIED BY AN ASTERISK (\*).
  - ALL SLOPES ARE EXPRESSED AS UNITS OF VERTICAL DISPLACEMENT TO UNITS OF HORIZONTAL DISPLACEMENT (V:H).
  - GRATING IS DESIGNED FOR A TRANSVERSING LOAD OF 1,800 POUNDS AT YIELD.

REVISIONS

DATE	DESCRIPTION
03-01-2022	REVISED BAR NO. 1 THICKNESS AND WEIGHT OF HEADWALL GRATES
03-31-2016	STATION, OFFSET AND INVERT ELEVATION MOVED
02-07-2012	DELETED SECTION VIEW FROM SKEW PLAN

GRATING FOR  
HEADWALL TYPE IV PIPE  
AND PIPE-ARCH CULVERTS

VERSION: 2022-03  
STANDARD: B23-04  
SHEET: 1 OF 1

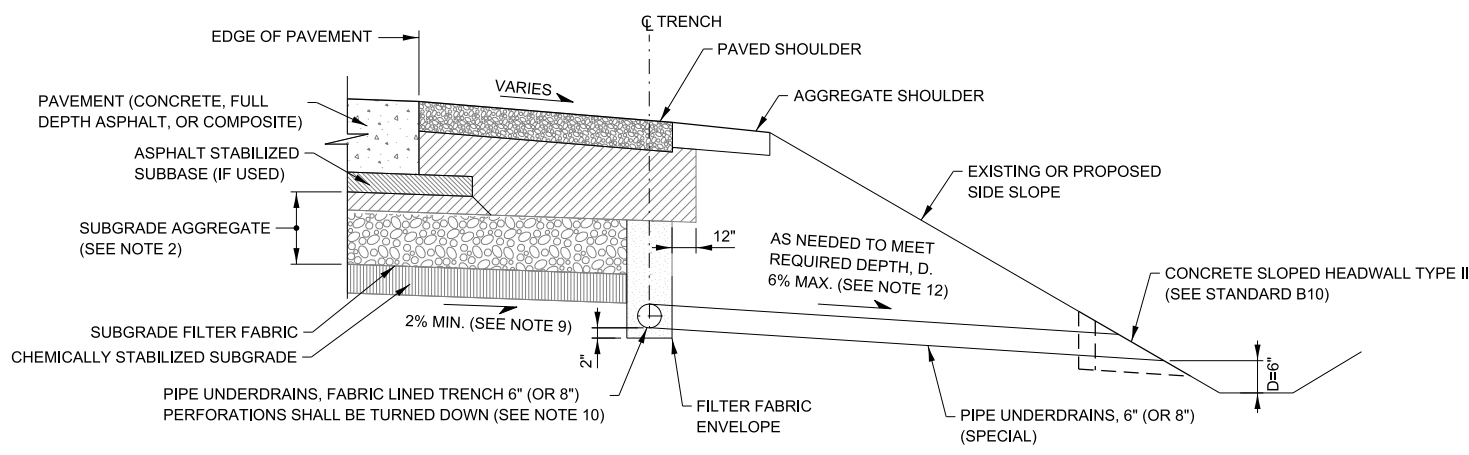

LOCATIONS WITHOUT GUTTER

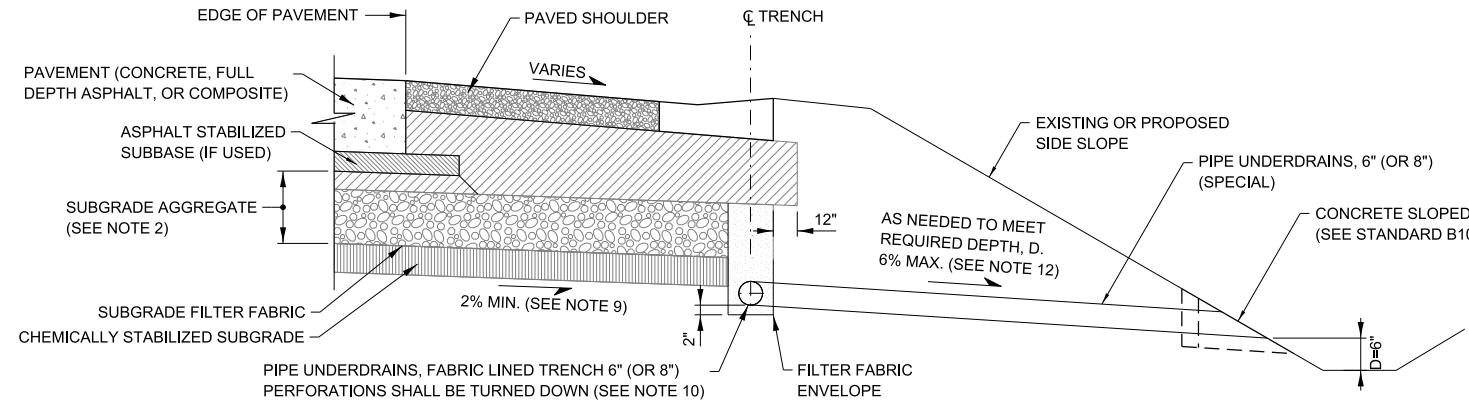

LOCATIONS WITH GUTTER

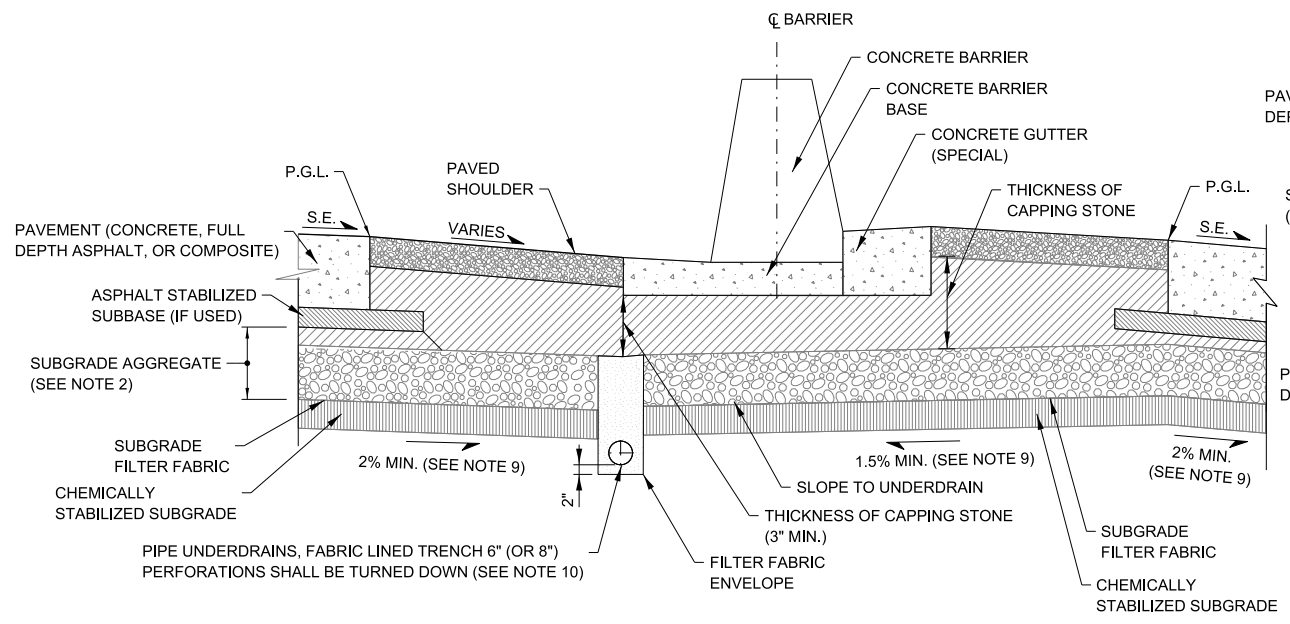

LOCATIONS WITH VARIABLE HEIGHT DOUBLE FACE BARRIER

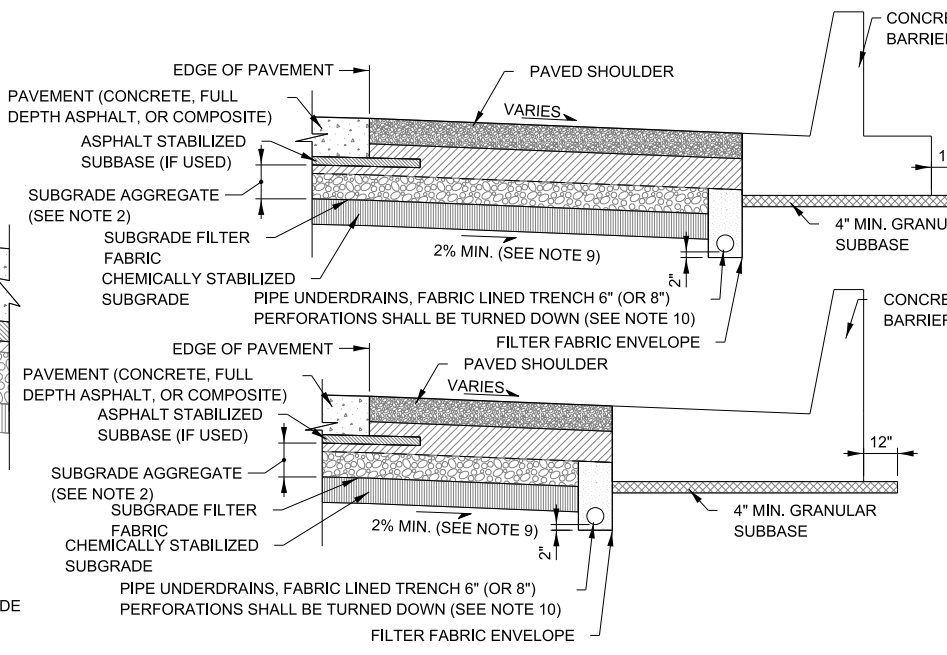

LOCATIONS WITH BARRIER

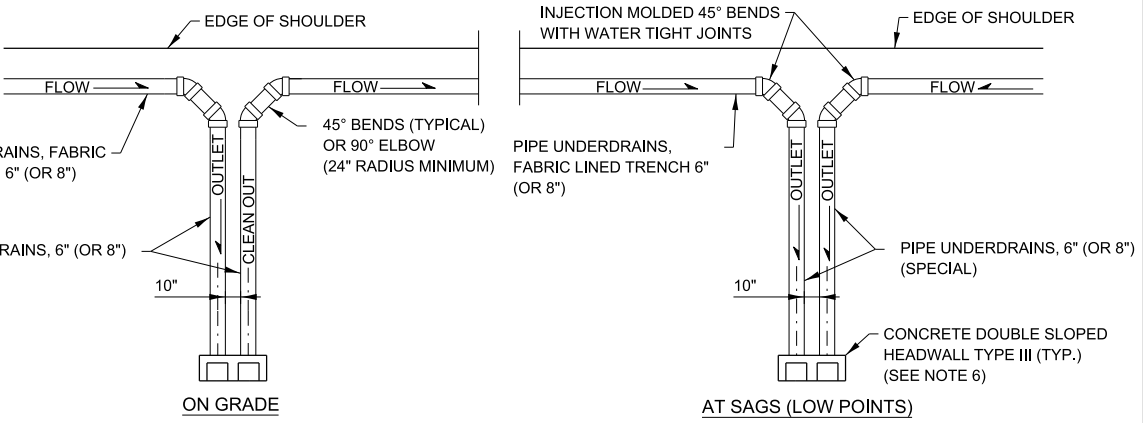

DETAIL OF PIPE UNDERDRAIN OUTLETS (SEE NOTE 7)

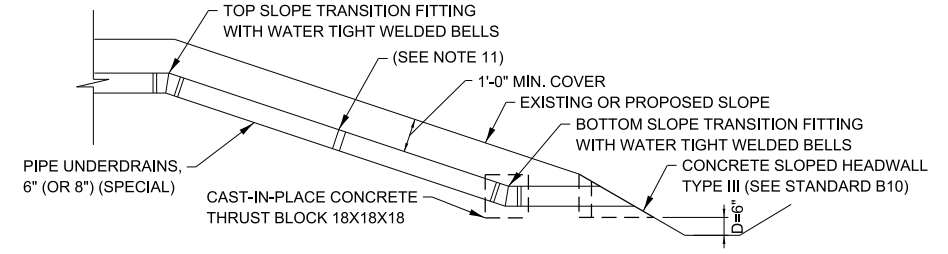

DETAIL OF PIPE UNDERDRAIN OUTLET ON HIGH FILL SLOPE

NOTES FOR PIPE UNDERDRAIN

- FOR NEW CONSTRUCTION OR WIDENING PROJECTS, THE PIPE UNDERDRAIN INSTALLATION SHALL OCCUR AFTER SUBGRADE HAS BEEN PREPARED AND AFTER LIFT OF PGE BASE IS PLACED AND BEFORE 3" AND VARIES CA-6 CAPPING STONE IS PLACED. FOR PAVEMENT RUBBLIZATION PROJECTS, THE PIPE UNDERDRAIN SHALL BE INSTALLED PRIOR TO RUBBLIZATION.
- SUBGRADE AGGREGATE SHALL CONSIST OF A 3" AND VARIES CA-6 CAP ABOVE A PGE BASE, THICKNESS AS NOTED IN THE PLANS.
- ON SUPERELEVATED CURVES PLACE LONGITUDINAL UNDERDRAIN ON LOW SIDE ONLY.
- IN AREAS WHERE ROADWAY LONGITUDINAL GRADE IS LESS THAN 0.5%, DIMENSION WILL INCREASE AS NECESSARY TO MAINTAIN MINIMUM 0.5% SLOPE IN PIPE UNDERDRAIN.
- IF 500' MAXIMUM DISTANCE IS EXCEEDED, PIPE UNDERDRAIN SHALL BE INCREASED TO 8" DIAMETER AND TRENCH WIDTH INCREASED TO 16".
- AT OUTLET LOCATIONS, PIPE UNDERDRAINS SHALL SEPARATE SUFFICIENTLY TO PROVIDE SPACE FOR TWO CONCRETE SLOPED HEADWALLS, OR TWO PIPES CAN RUN PARALLEL INTO A DOUBLE SLOPED HEADWALL.
- IN AREAS WHERE A CLOSED DRAINAGE SYSTEM EXISTS, THE PIPE UNDERDRAIN, 6" (OR 8") (SPECIAL) SHALL DRAIN TO THE NEAREST CATCH BASIN. THE UPPER END OF A RUN ON GRADE SHALL ALSO BE CONNECTED TO A CATCH BASIN TO BE USED AS A CLEANOUT.
- THE OUTLET END OF THE SUBDRAIN SHALL BE PROTECTED BY A PERMANENT RODENT SHIELD. THE RODENT SHIELD SHALL HAVE THE CONFIGURATION SHOWN AND BE CONSTRUCTED FROM HOT DIP GALVANIZED STEEL INDUSTRIAL WIRE CLOTH 3x3 MESH, 0.063"x0.063" WIRE SIZE IN ACCORDANCE WITH AASHTO M232 (ASTM A153).
- BOTTOM OF SUBGRADE AGGREGATE SLOPE FROM ROADWAY PROFILE GRADE SHALL NOT BE LESS THAN 1.5% TOWARD THE PIPE UNDERDRAIN IN SUPERELEVATED SECTIONS.
- A CA 16 BACKFILLED TRENCH SHALL BE USED WITH THE INSTALLATION OF A PIPE UNDERDRAIN SYSTEM, EXCEPT THE PERCENT PASSING THE NO. 16 (1.18 mm) SIEVE SHALL BE 4 ± 4 PERCENT.
- ALL JOINTS IN SLOPE DRAIN SYSTEM SHALL BE WATERTIGHT WITH A WELDED INTERNAL CYLINDER ON THE SPIGOT END OF THE PIPE. FIELD JOINTS SHALL BE WRAPPED WITH A DOUBLE WIDE MARMAC COUPLER, OR EQUIVALENT.
- IF REQUIRED PIPE UNDERDRAIN SLOPE EXCEEDS 6%, PIPE UNDERDRAIN OUTLET ON HIGH FILL SLOPE DETAIL SHALL APPLY.

MAXIMUM ALLOWABLE DRAINAGE DISTANCE TO OUTLET OR SEPARATION DISTANCE BETWEEN OUTLETS	
ROADWAY PROFILE GRADE (%)	DISTANCE
≤ 1	250 FT.
BETWEEN 1 AND 2	375 FT.
≥ 2	500 FT. (NOTE 5)

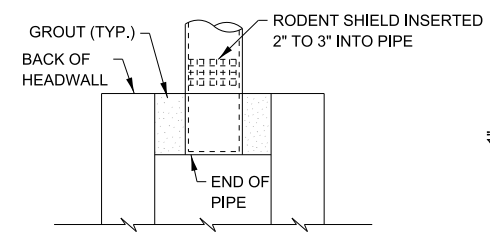

RODENT SHIELD PLACEMENT

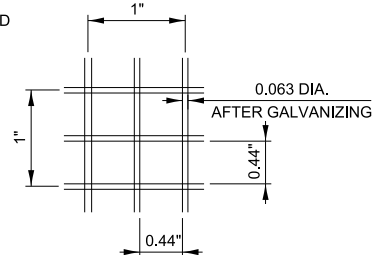

SECTION A-A

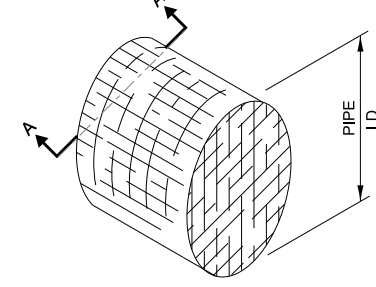

DETAIL OF RODENT SHIELD

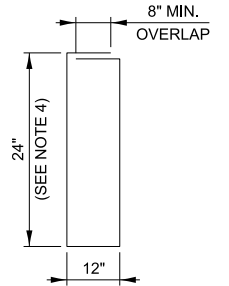

FILTER FABRIC ENVELOPE

APPROVED BY: *Paul Kovacs* CHIEF ENGINEERING OFFICER  
DATE: 03/01/2021

REVISIONS	
DATE	DESCRIPTION
03-01-2021	ADDED DETAIL FOR BARRIER
03-01-2020	ADDED COMPOSITE PAVEMENT AS OPTION
03-01-2019	REVISED PIPE UNDERDRAIN OUTLETS
	ADDED DETAIL FOR HIGH FILL SLOPE



PIPE UNDERDRAINS

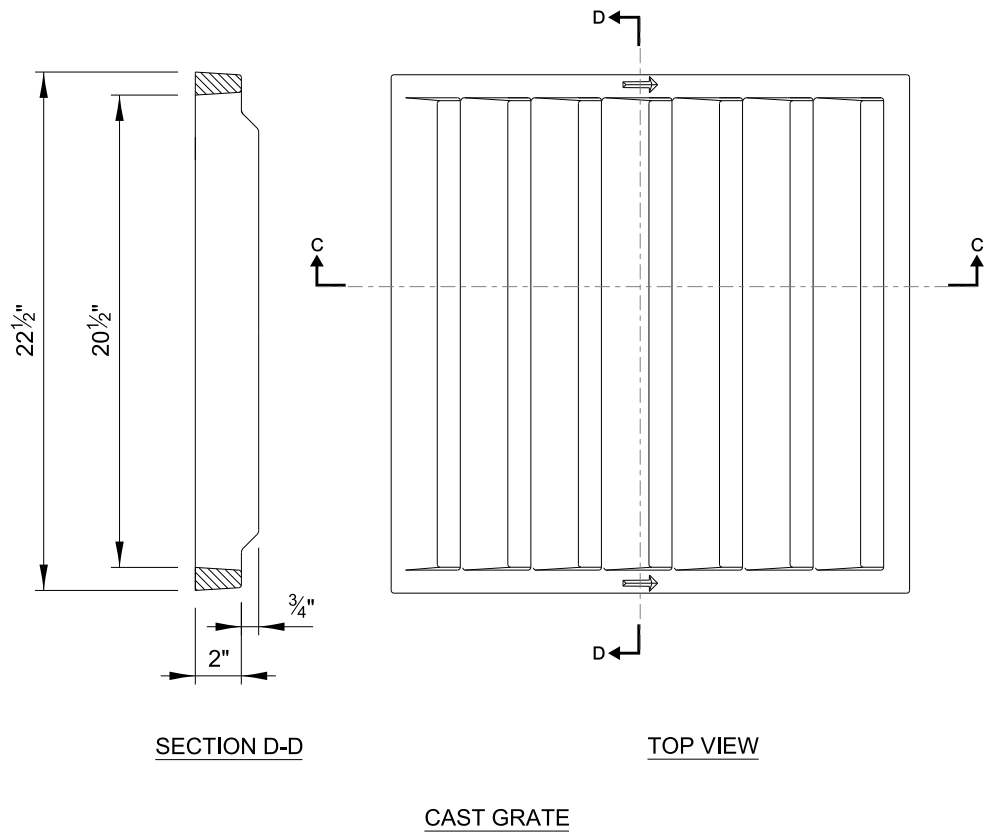
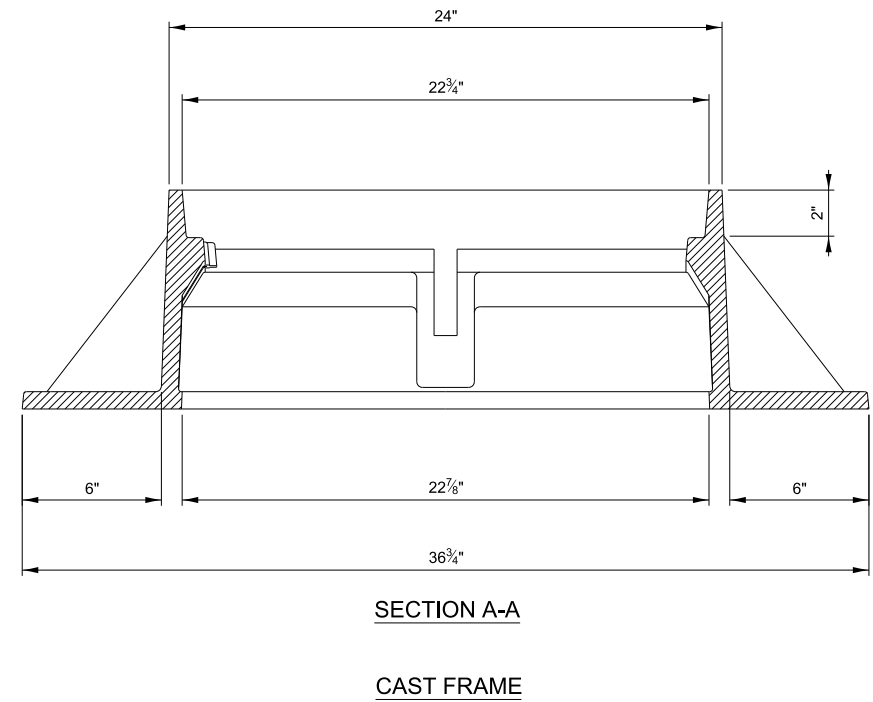
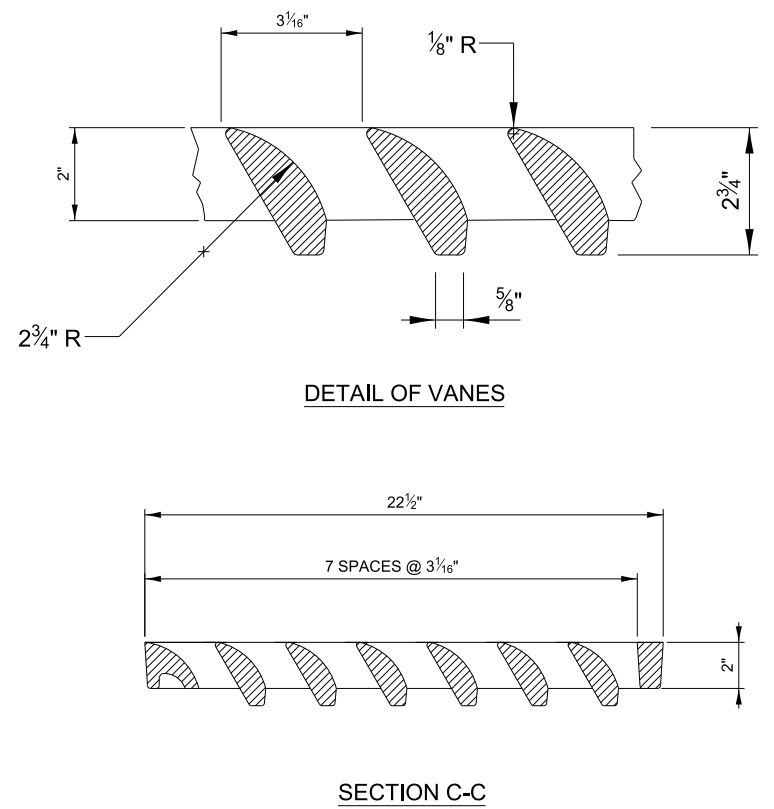
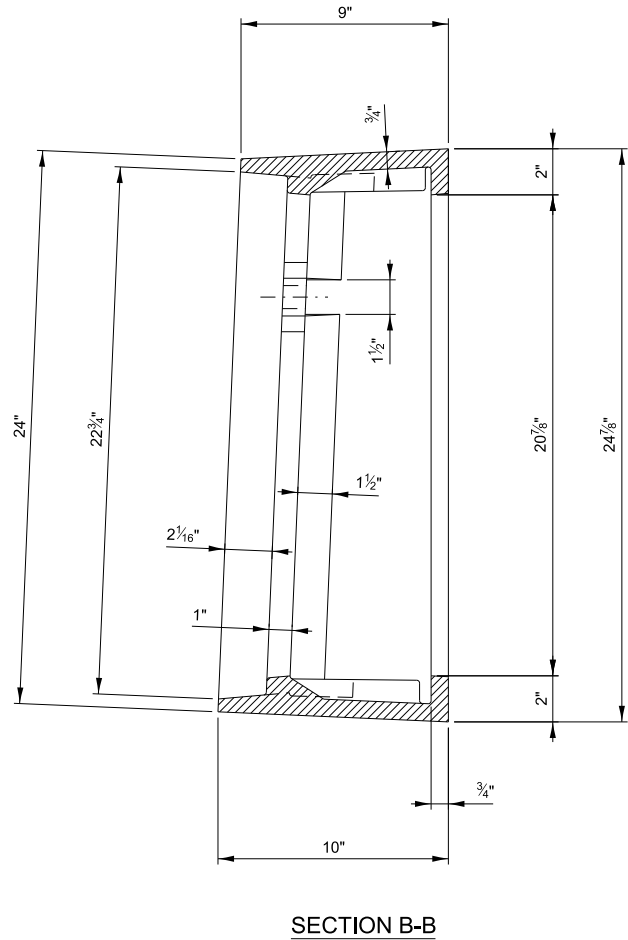
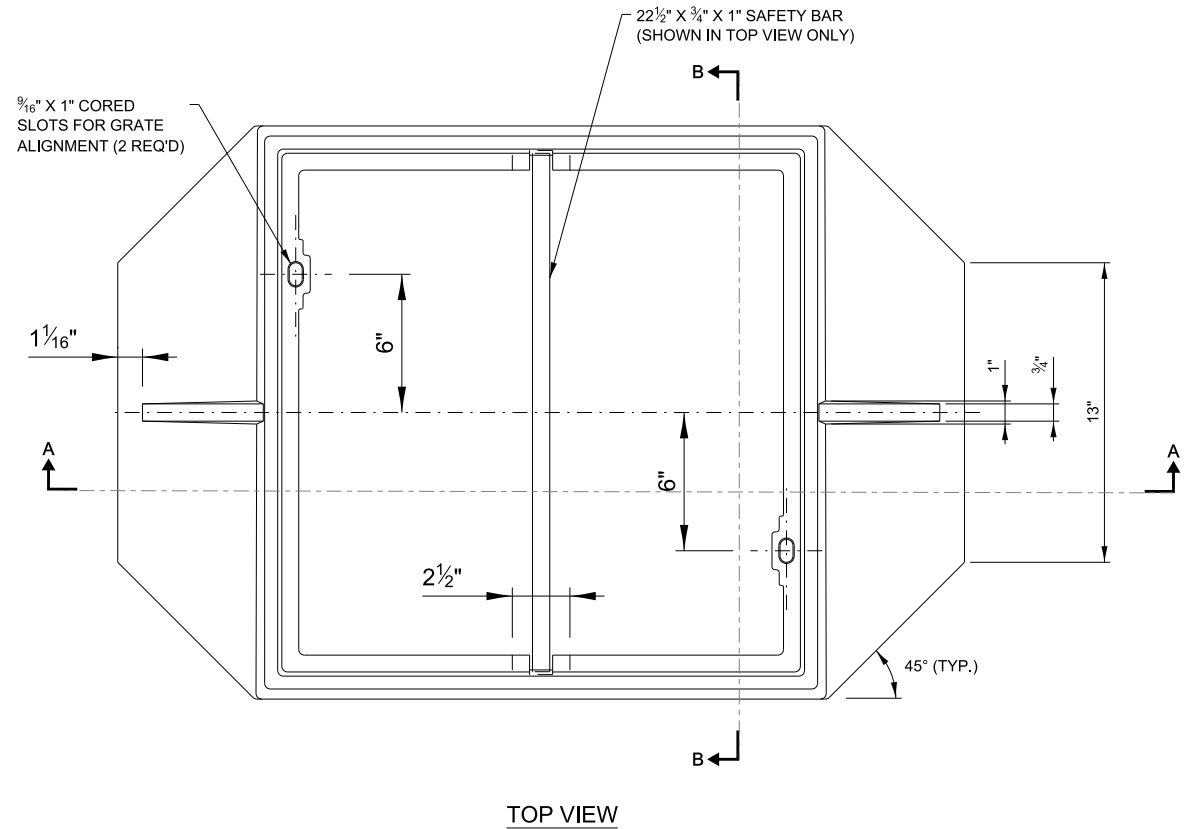

- NOTES:
1. ALL FRAMES AND GRATES SHALL CONFORM TO THE REQUIREMENTS OF ART. 1006.14 FOR GRAY IRON CASTINGS AND TO ART. 1006.15 FOR DUCTILE IRON CASTINGS.
  2. FRAME AND GRATE TO BE NEENAH FOUNDRY COMPANY, NEENAH NO. R-3528-V, EAST JORDAN IRON WORKS 7535 OR APPROVED EQUAL.
  3. GRATE SHALL NOT BE BOLTED TO FRAME.

APPROVED BY: *Paul Kovacs* CHIEF ENGINEERING OFFICER

DATE: 03/01/2014

REVISIONS	
DATE	DESCRIPTION
03-31-2014	ADDED FRAME AND GRATE CASTINGS

**FRAME AND GRATE TYPE 20A**

VERSION: 2014-03      STANDARD: B25-01      SHEET: 1 OF 1

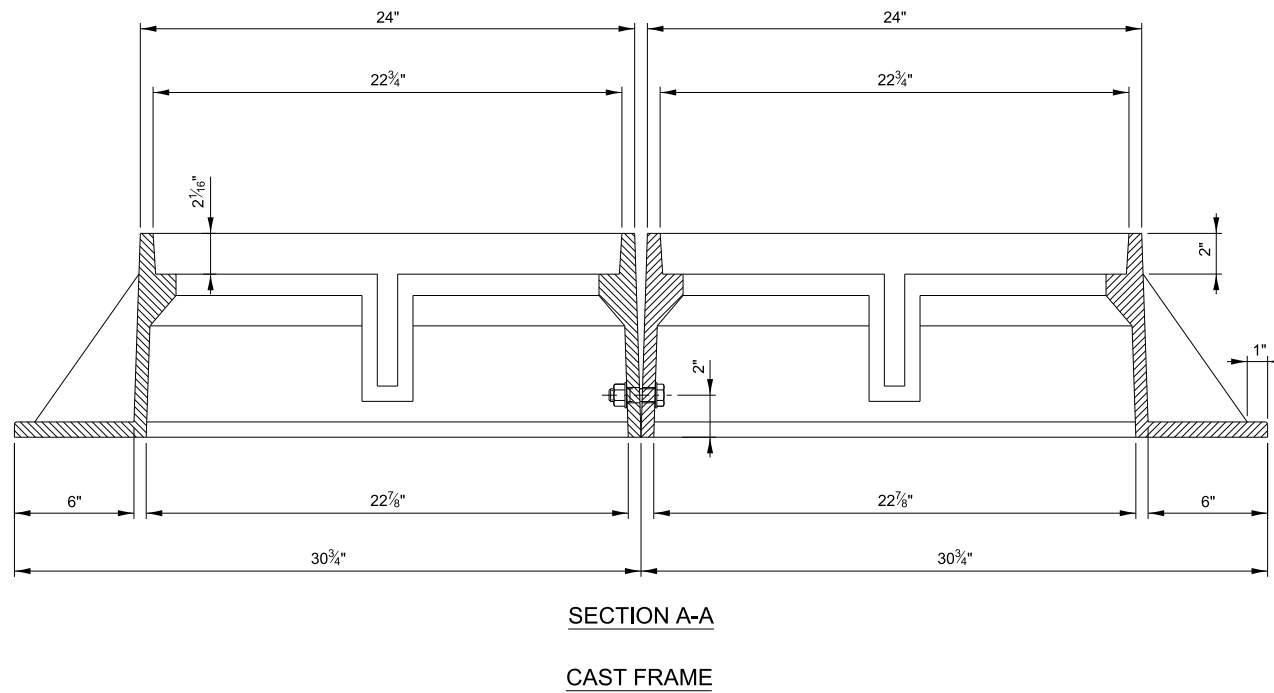
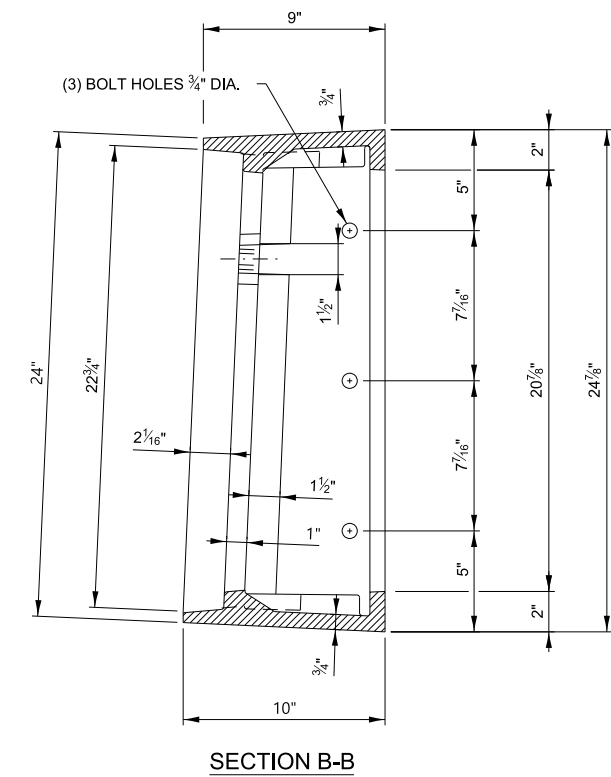
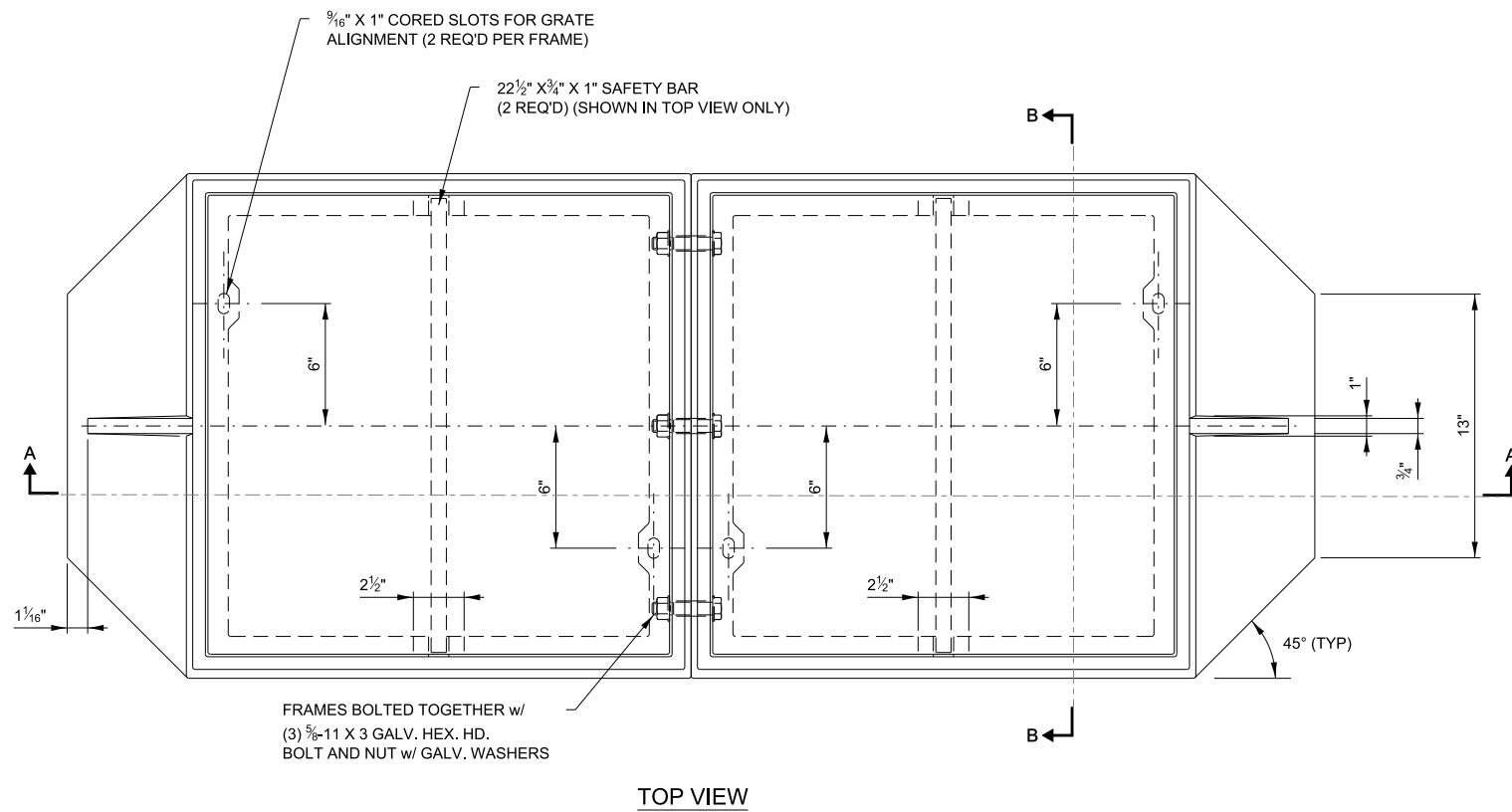

APPROVED BY: *Paul Kovacs*  
 CHIEF ENGINEERING OFFICER

DATE: 03/01/2014

REVISIONS	
DATE	DESCRIPTION
03-31-2014	ADDED FRAME AND GRATE CASTINGS



**FRAME AND GRATE  
TYPE 22A**

VERSION: 2014-03      STANDARD: B27-01      SHEET: 1 OF 2

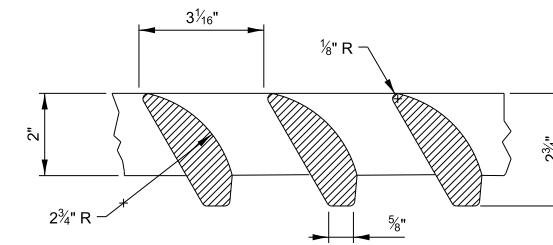

DETAIL OF VANES

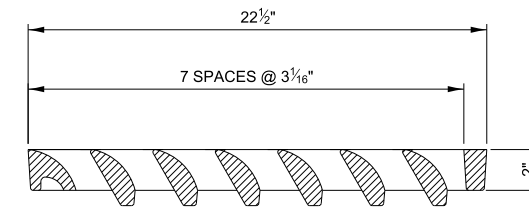

SECTION C-C

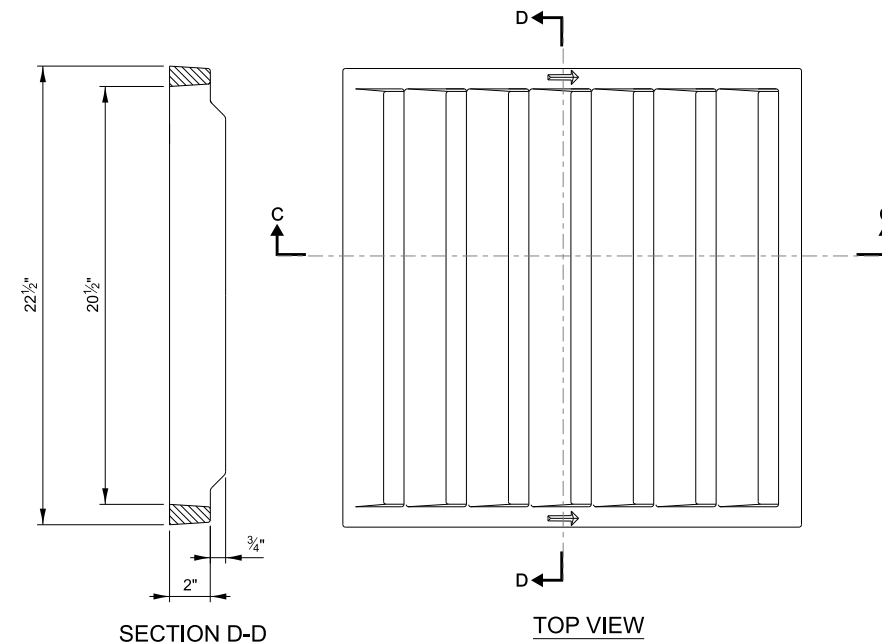

SECTION D-D

TOP VIEW

CAST GRATE  
(2 REQ'D)

NOTES:

1. ALL FRAMES AND GRATES SHALL CONFORM TO THE REQUIREMENTS OF ART. 1006.14 FOR GRAY IRON CASTINGS AND TO ART. 1006.15 FOR DUCTILE IRON CASTINGS.
2. FRAME AND GRATE TO BE NEENAH FOUNDRY COMPANY, NEENAH NO. R-3529-V, EAST JORDAN IRON WORKS 7536 OR APPROVED EQUAL.
3. GRATE SHALL NOT BE BOLTED TO FRAME.



FRAME AND GRATE  
TYPE 22A

APPROVED BY:

DATE:

*Paul Kovacs*  
CHIEF ENGINEERING OFFICER

03/01/2014

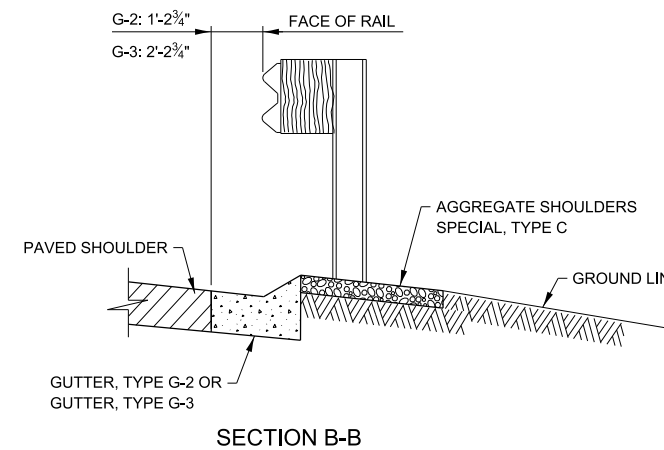
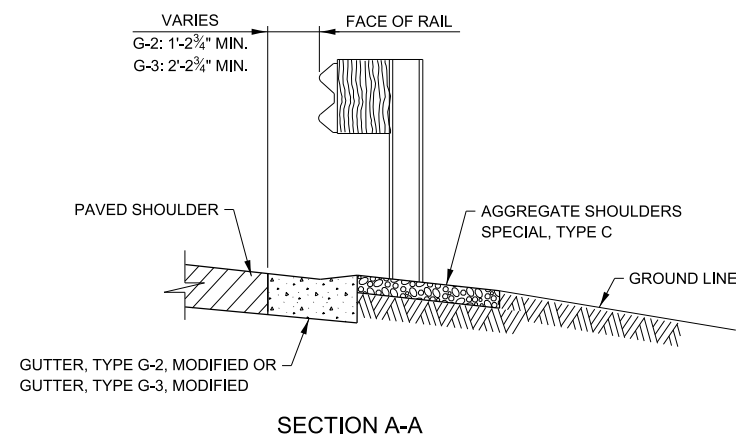
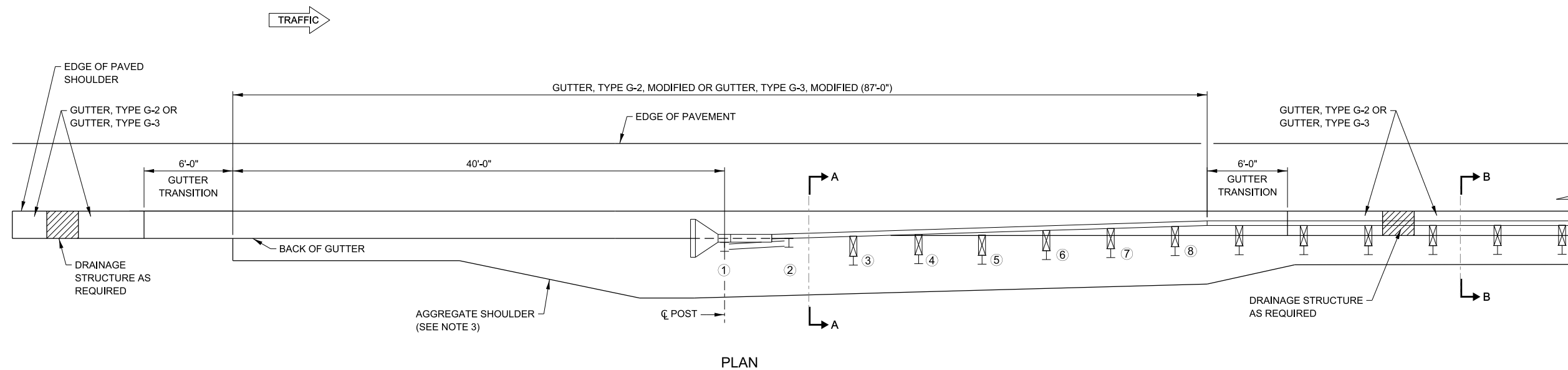

**GUTTER, TYPE G-2 TRANSITION AND GUTTER, TYPE G-3 TRANSITION  
AT TRAFFIC BARRIER TERMINAL, TYPE T1 (SPECIAL)**

**GENERAL NOTES:**

1. GUTTER TRANSITIONS SHALL BE PAID FOR PER FOOT AS GUTTER, TYPE G-2 OR GUTTER, TYPE G-3, AS SPECIFIED IN THE PLANS.
2. REFERENCE ILLINOIS TOLLWAY STANDARD DRAWING C1 FOR ADDITIONAL GUARDRAIL INFORMATION.
3. REFERENCE ILLINOIS TOLLWAY STANDARD DRAWING C6 FOR SHOULDER WIDENING INFORMATION.

APPROVED BY: *Paul Kovacs* CHIEF ENGINEERING OFFICER  
DATE: 03/01/2018

REVISIONS	
DATE	DESCRIPTION
03-01-2018	CHANGED LINSTYLE AT WEDGE TO DASHED
03-31-2017	DELETED SHEET 2
03-11-2015	REVISED NOTES
03-01-2013	REVISED GUTTER
01-01-2011	REVISED GUTTER TRANSITION TERM

  
**GUTTER TRANSITION AT TRAFFIC BARRIER TERMINAL TYPE T1 (SPECIAL)**

VERSION: 2018-03	STANDARD: B28-05	SHEET: 1 OF 2
------------------	------------------	---------------

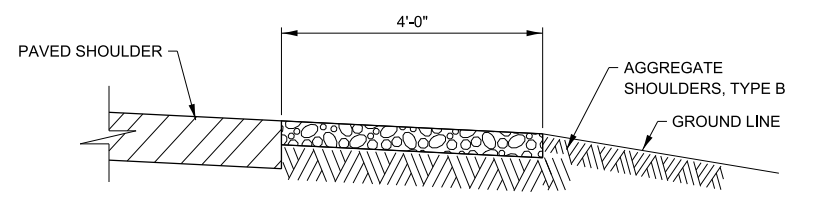
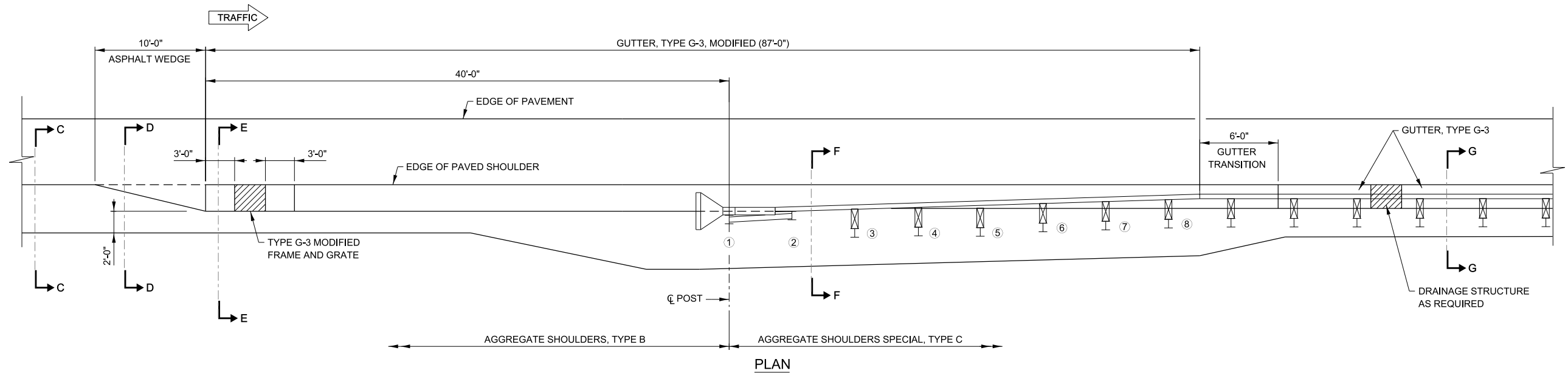

SECTION C-C

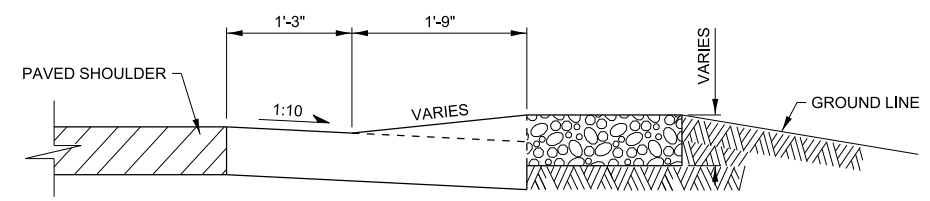

SECTION E-E  
GUTTER, TYPE G-3, MODIFIED TRANSITION

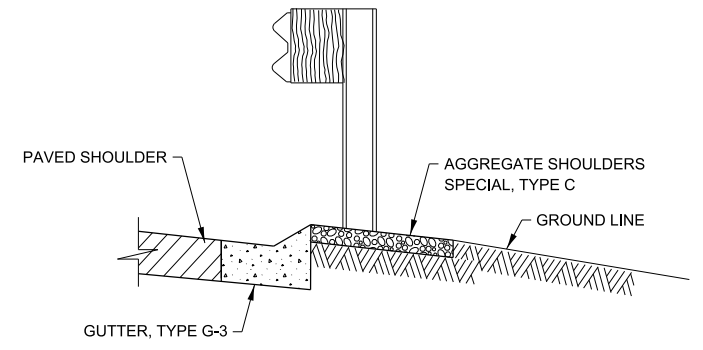

SECTION G-G

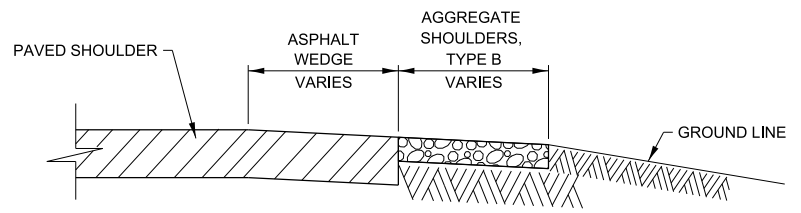

SECTION D-D  
ASPHALT SHOULDER TRANSITION

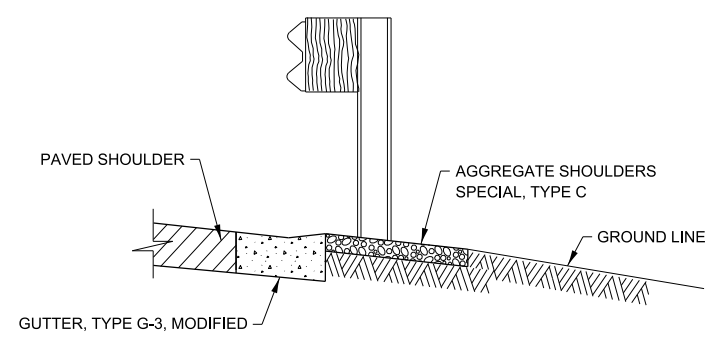

SECTION F-F

GUTTER, TYPE G-3 TRANSITION TERMINATION AT TRAFFIC BARRIER TERMINAL, TYPE T1 (SPECIAL)

NOTE:  
SEE SHEET 1 OF THIS SERIES FOR NOTES

APPROVED BY: *Paul Kovacs*  
CHIEF ENGINEERING OFFICER

DATE: 03/01/2018

GUTTER TRANSITION AT TRAFFIC BARRIER TERMINAL TYPE T1 (SPECIAL)

VERSION: 2018-03	STANDARD: B28-05	SHEET: 2 OF 2
---------------------	---------------------	------------------

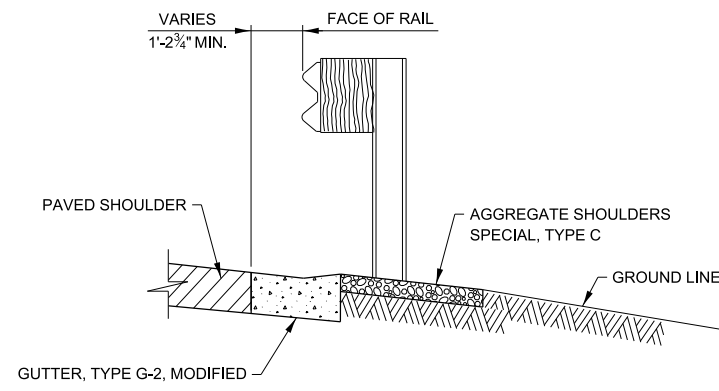
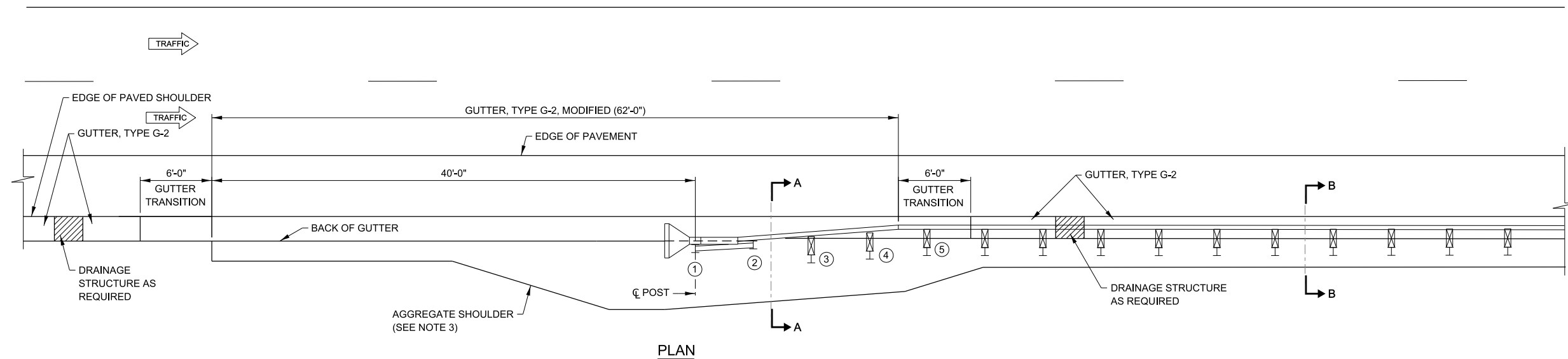

SECTION A-A

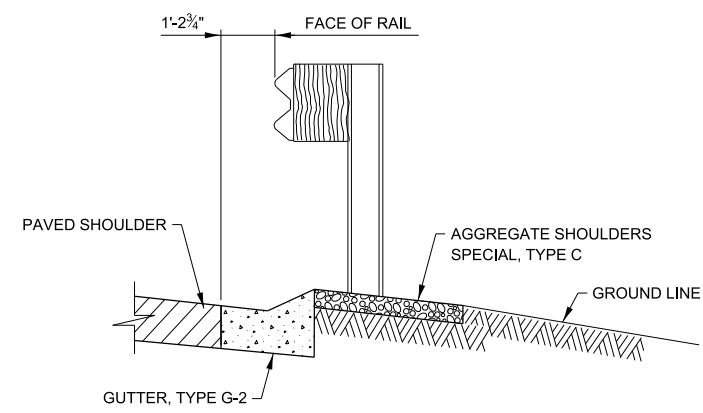

SECTION B-B

GUTTER, TYPE G-2 TRANSITION AT TRAFFIC BARRIER TERMINAL, TYPE T1-A (SPECIAL)

GENERAL NOTES:

1. GUTTER TRANSITIONS SHALL BE PAID FOR PER FOOT AS GUTTER, TYPE G-2 OR AS SPECIFIED IN THE PLANS.
2. REFERENCE ILLINOIS TOLLWAY STANDARD DRAWING C1 FOR ADDITIONAL GUARDRAIL INFORMATION.
3. REFERENCE ILLINOIS TOLLWAY STANDARD DRAWING C12 FOR SHOULDER WIDENING INFORMATION.

APPROVED BY: *Paul Kovacs*  
 CHIEF ENGINEERING OFFICER  
 DATE: 03/31/2017

REVISIONS	
DATE	DESCRIPTION
03-31-2017	REMOVED SHLDR DIMS
03-11-2015	REVISED NOTES
03-01-2013	REVISED GUTTER

**Illinois Tollway**

**GUTTER TRANSITION AT TRAFFIC BARRIER TERMINAL TYPE T1-A (SPECIAL)**

VERSION: 2017-03	STANDARD: B29-03	SHEET: 1 OF 1
---------------------	---------------------	------------------

NOTES:

- SLOPED HEADWALLS TYPES I AND II SHALL BE CONSTRUCTED FLUSH WITH EXISTING OR PROPOSED SLOPE.
- CLASS SI CONCRETE SHALL BE USED THROUGHOUT.
- ALL REINFORCEMENT BARS SHOWN SHALL BE EPOXY COATED (E).
- BAR BENDING DETAILS ARE DIMENSIONED OUT TO OUT OF BARS.
- ALL EXPOSED EDGES SHALL HAVE A 3/4"-45° CHAMFER. CHAMFER ON VERTICAL EDGES SHALL BE CONTINUED A MINIMUM OF ONE FOOT BELOW THE FINISHED GROUND LINE.
- COVER FROM THE FACE OF CONCRETE TO FACE OF REINFORCEMENT BAR SHALL BE 3" FOR SURFACES FORMED AGAINST EARTH AND 2" FOR ALL OTHER SURFACES UNLESS OTHERWISE SHOWN.
- CARE SHALL BE EXERCISED IN REMOVING ANY LENGTH OF EXISTING PIPE SO THE REMAINING PIPE IS UNDAMAGED AND FULLY FUNCTIONING.
- ALL SLOPES ARE EXPRESSED AS UNITS OF VERTICAL DISPLACEMENT TO UNITS OF HORIZONTAL DISPLACEMENT.
- TYPES I AND II HEADWALLS TO BE USED ONLY FOR SLOPES STEEPER THAN 1:3. DIMENSIONS AND QUANTITIES ARE BASES ON A SLOPE 1:2.
- I.D. DENOTES INSIDE DIAMETER OF PIPE. O.D. DENOTES OUTSIDE DIAMETER OF PIPE.
- FOR EROSION PROTECTION SEE STANDARD B19.

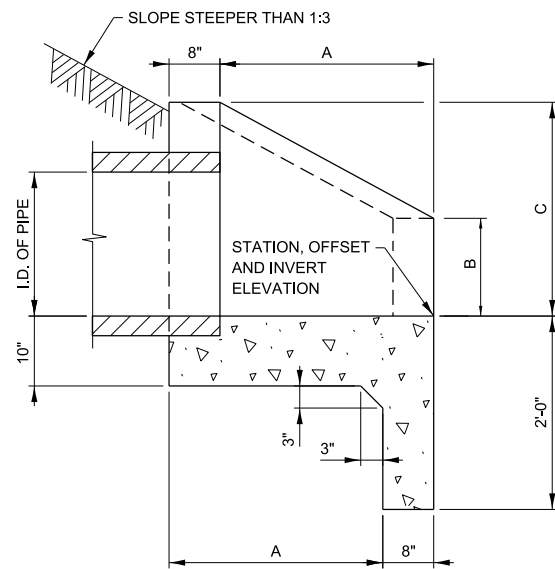

SECTION A-A  
(DIMENSIONS)

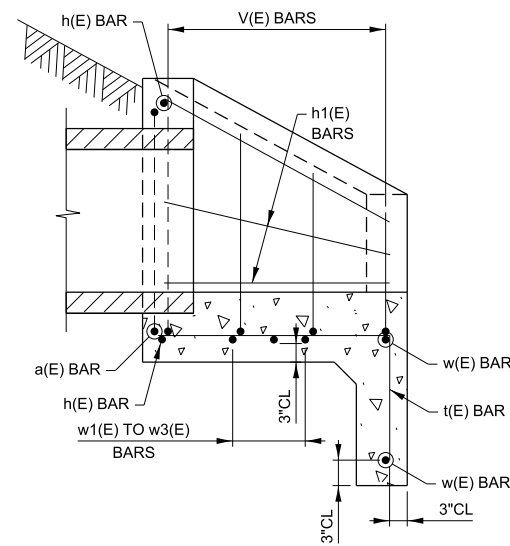

SECTION A-A  
(REINFORCEMENT)

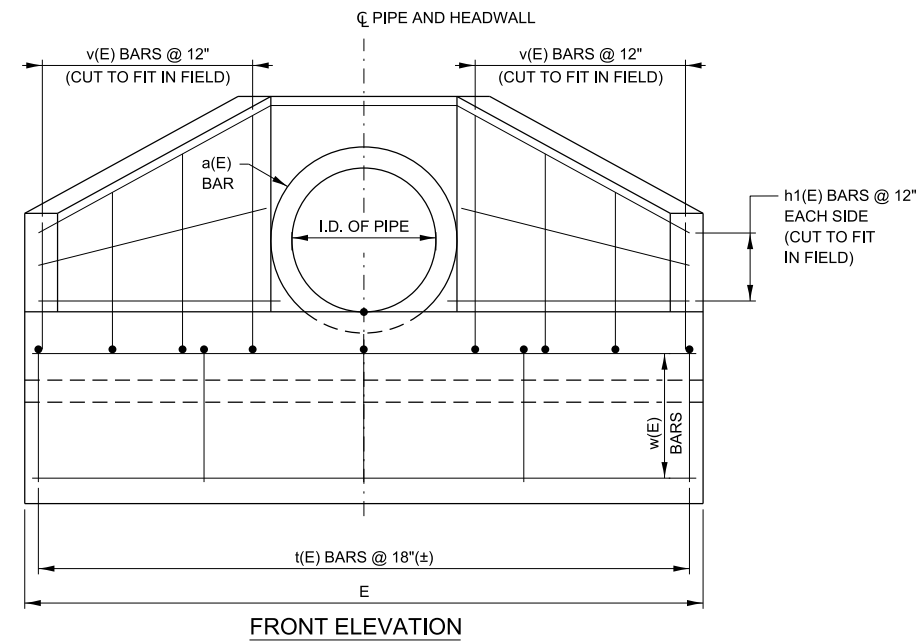

FRONT ELEVATION

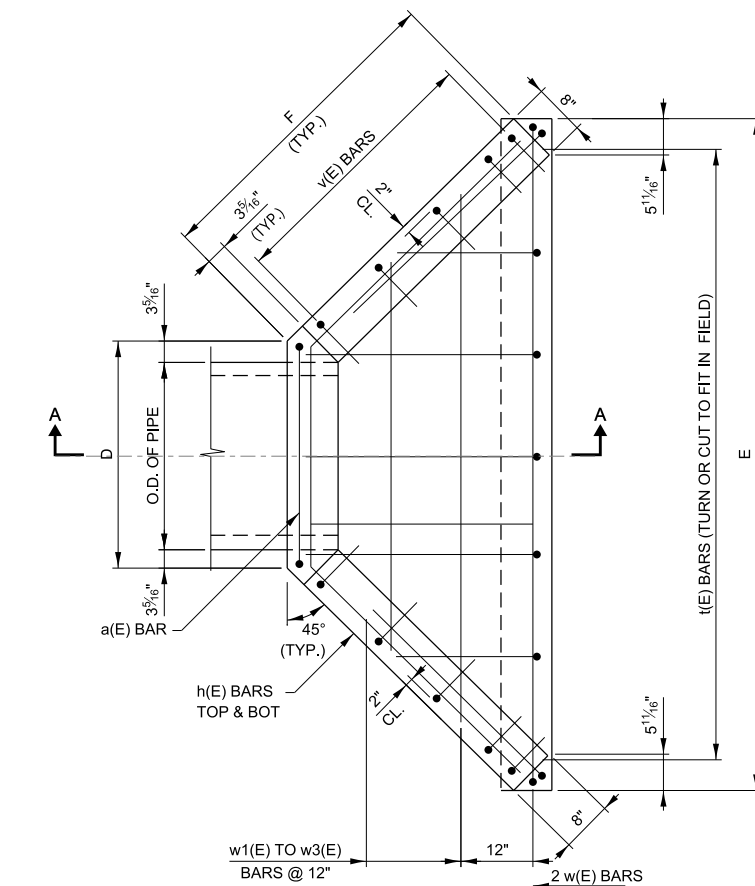

PLAN

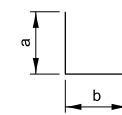

v(E) - BARS

t(E) - BARS

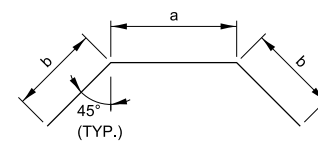

h(E) BARS

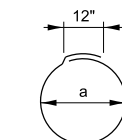

a(E) BARS

HEADWALL - TYPE I  
(PIPE DIAMETER ≤36")

TABLE OF DIMENSIONS AND QUANTITIES FOR ONE HEADWALL

INSIDE DIA. OF PIPE	SLOPE OF FILL	DIMENSIONS						CONCRETE CLASS SI	REINF. BARS (POUND)
		A	B	C	D	E	F		
21"	1:3	4'-0"	1'-2"	2'-6"	2'-9 1/8"	11'-1 1/8"	5'-11 3/16"	1.6 C.Y.	75
24"	1:3	4'-3"	1'-4"	2'-9"	3'-0 5/8"	11'-11 3/8"	6'-3 7/16"	2.1 C.Y.	80
27"	1:3	4'-0"	1'-8"	3'-0"	3'-4 1/8"	11'-8 7/8"	5'-11 3/16"	2.0 C.Y.	100
30"	1:3	5'-0"	1'-7"	3'-3"	3'-7 7/8"	14'-0 3/8"	7'-4 3/16"	2.7 C.Y.	120
36"	1:3	6'-0"	1'-10"	3'-10"	4'-2 3/8"	16'-7 3/8"	8'-9 1/8"	3.6 C.Y.	145

TABLE OF REINFORCING STEEL FOR ONE HEADWALL

MARK (E)	SIZE	NO.	21" I.D. PIPE				24" I.D. PIPE				27" I.D. PIPE				30" I.D. PIPE				36" I.D. PIPE			
			LENGTH	a	b		NO.	LENGTH	a	b		NO.	LENGTH	a	b		NO.	LENGTH	a	b		
a	#4	1	9'-3"	3 1/2"	-	1	10'-2"	2'-11"	-	1	11'-1"	3'-2"	-	1	12'-0"	3'-6"	-	1	13'-10"	4'-1"	-	
h	#4	2	8'-7"	2'-3"	3'-2"	2	10'-2"	2'-6"	3'-10"	2	11'-0"	2'-10"	4'-1"	2	9'-5"	3'-1"	3'-2"	2	11'-0"	3'-8"	4'-1"	
h1	#4	4	3'-2"	-	-	4	3'-10"	-	-	4	4'-2"	-	-	5	4'-7"	-	-	6	5'-6"	-	-	
v	#4	6	4'-0"	1'-0"	3'-0"	8	4'-3"	1'-0"	3'-3"	8	4'-8"	1'-0"	3'-6"	10	4'-9"	1'-0"	3'-9"	10	5'-4"	1'-0"	4'-4"	
t	#4	6	4'-0"	1'-6"	2'-6"	6	4'-3"	1'-6"	2'-9"	6	4'-8"	1'-6"	3'-1"	7	4'-10"	1'-6"	3'-4"	8	5'-4"	1'-6"	3'-10"	
w	#4	2	7'-7"	-	-	2	8'-6"	-	-	2	10'-1"	-	-	2	10'-0"	-	-	2	12'-0"	-	-	
w1	#4	1	6'-0"	-	-	1	6'-11"	-	-	1	7'-11"	-	-	1	8'-7"	-	-	1	10'-6"	-	-	
w2	#4	1	-	-	-	1	4'-11"	-	-	1	5'-11"	-	-	1	6'-7"	-	-	1	8'-6"	-	-	
w3	#4	-	-	-	-	-	-	-	-	-	-	-	-	1	4'-7"	-	-	1	7'-6"	-	-	



HEADWALLS  
TYPE I AND II

REVISIONS	
DATE	DESCRIPTION
03-01-2022	REVISED HEADWALL DIMENSIONS
03-11-2015	REVISED NOTES
02-07-2012	ADDED 21" AND 27" DIA PIPE AND REVISED TABLE QUANTITIES

APPROVED BY:

DATE:

Paul Kovacs  
CHIEF ENGINEERING OFFICER

03/01/2022

NOTE:

1. FOR ADDITIONAL NOTES SEE SHEET 1 IN THIS SERIES.

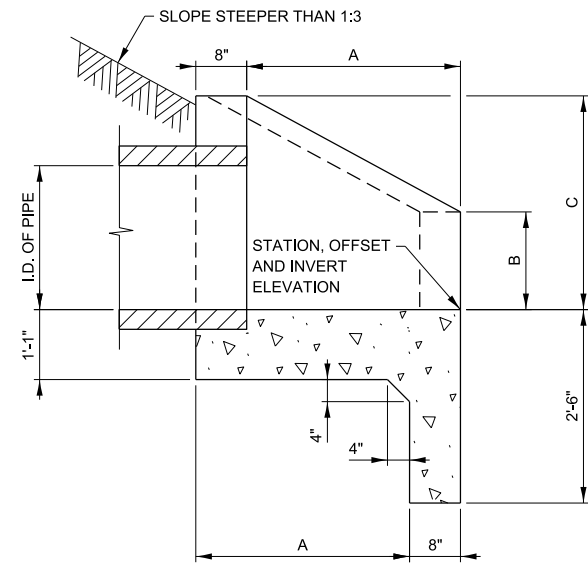

SECTION A-A  
(DIMENSIONS)

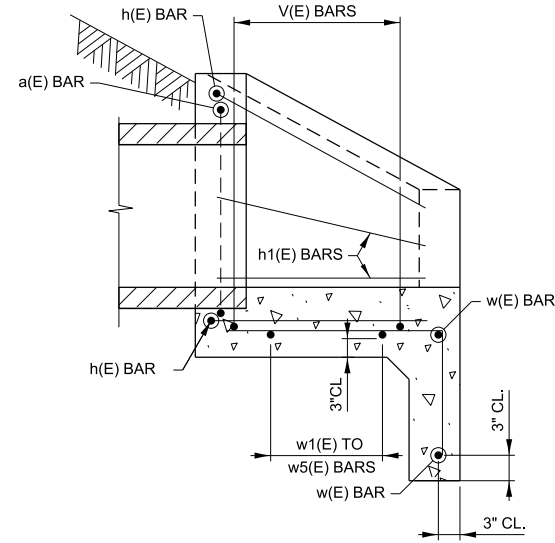

SECTION A-A  
(REINFORCEMENT)

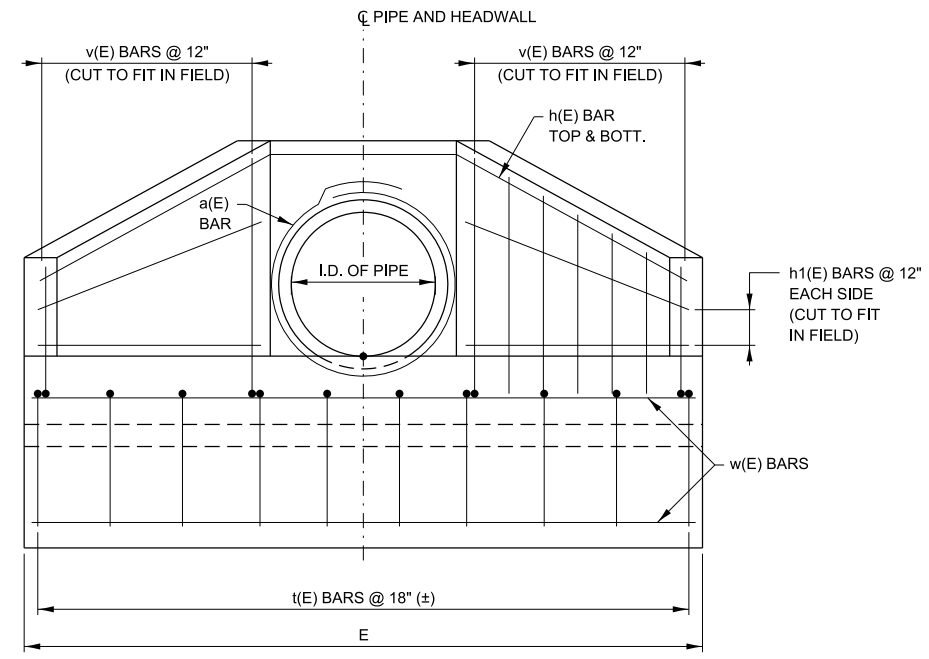

FRONT ELEVATION

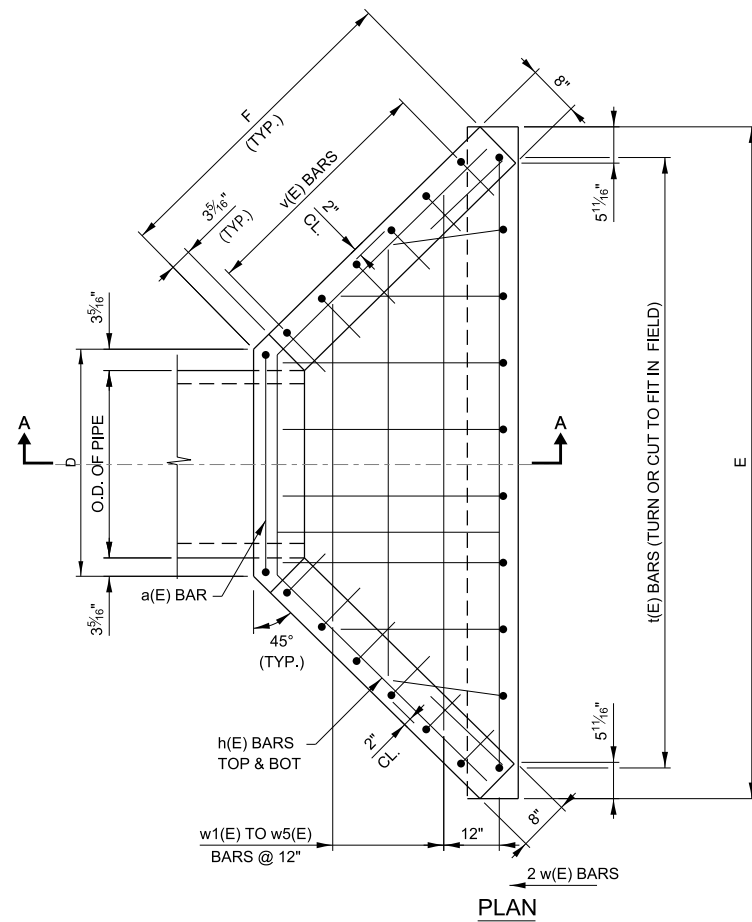

PLAN

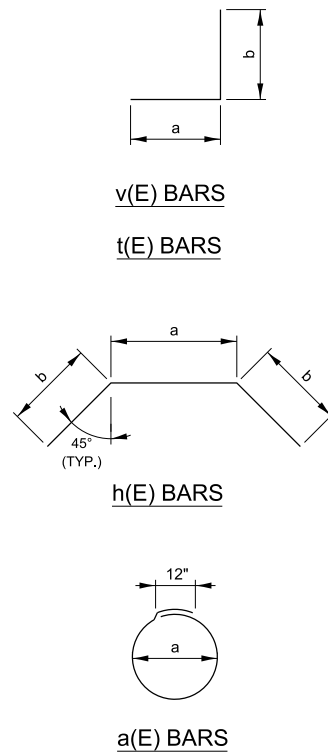

HEADWALL - TYPE II  
(PIPE DIAMETER ≥ 36")

TABLE OF BARS FOR ONE HEADWALL

MARK (E)	SIZE	NO.	42" PIPE		48" PIPE		54" I.D. PIPE		60" I.D. PIPE								
			LENGTH	a	b	NO.	LENGTH	a	b	NO.	LENGTH	a	b				
a	#5	2	15'-11"	4'-9"	-	2	17'-9"	5'-4"	-	2	19'-7"	5'-11"	-	2	21'-5"	6'-6"	-
h	#5	2	17'-7"	5'-3"	6'-2"	2	19'-9"	5'-9"	7'-0"	2	22'-0"	6'-4"	7'-10"	2	24'-1"	6'-9"	8'-8"
h1	#5	8	6'-6"	-	-	10	7'-4"	-	-	10	8'-2"	-	-	12	9'-0"	-	-
t	#5	10	6'-1"	1'-6"	4'-7"	11	6'-8"	1'-6"	5'-2"	13	7'-3"	1'-6"	5'-9"	15	7'-10"	1'-6"	6'-4"
v	#5	14	5'-10"	1'-0"	4'-10"	16	6'-6"	1'-0"	5'-6"	16	7'-1"	1'-0"	6'-1"	18	7'-8"	1'-0"	6'-8"
w	#5	2	14'-3"	-	-	2	15'-10"	-	-	2	17'-8"	-	-	2	18'-10"	-	-
w1	#5	1	12'-0"	-	-	1	13'-8"	-	-	1	15'-2"	-	-	1	16'-10"	-	-
w2	#5	1	10'-0"	-	-	1	11'-8"	-	-	1	13'-4"	-	-	1	15'-0"	-	-
w3	#5	1	8'-0"	-	-	1	9'-8"	-	-	1	11'-6"	-	-	1	13'-2"	-	-
w4	#5	-	-	-	-	1	8'-0"	-	-	1	9'-8"	-	-	1	11'-4"	-	-
w5	#5	-	-	-	-	-	-	-	-	-	7'-8"	-	-	1	9'-6"	-	-

TABLE OF DIMENSIONS AND QUANTITIES FOR ONE HEADWALL

INSIDE DIA. OF PIPE	SLOPE OF FILL	DIMENSIONS						CONCRETE CLASS SI	REINF. BARS (POUND)
		A	B	C	D	E	F		
42"	1:3	6'-7 1/2"	2'-2"	4'-4 1/2"	4'-9 5/8"	18'-5 3/8"	9'-7 3/4"	3.8 C.Y.	400
48"	1:3	7'-6"	2'-5"	4'-11"	5'-4 5/8"	20'-9 3/8"	10'-10 9/16"	4.1 C.Y.	450
54"	1:3	8'-4 1/2"	2'-8"	5'-5 1/2"	5'-11 3/8"	23'-1 3/8"	12'-1 1/16"	5.6 C.Y.	500
60"	1:3	9'-3"	2'-11"	6'-0"	6'-6 5/8"	25'-5 3/8"	13'-4 5/16"	6.5 C.Y.	600



HEADWALLS  
TYPE I AND II

APPROVED BY:

DATE:

*Paul Kovacs*  
CHIEF ENGINEERING OFFICER

03/01/2022

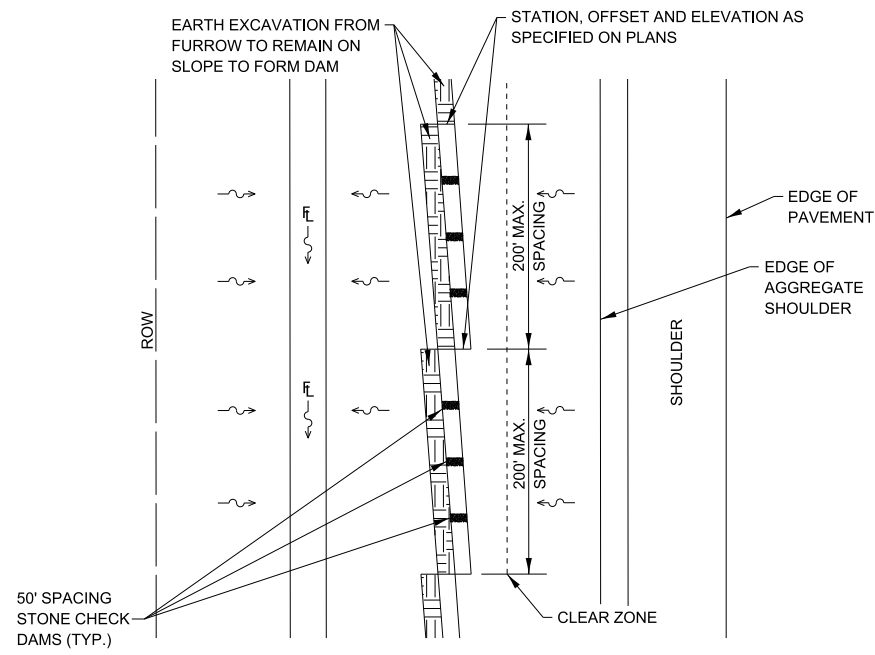

**DEFINED CLEAR ZONE LOCATIONS**  
PLAN VIEW: NOT TO SCALE

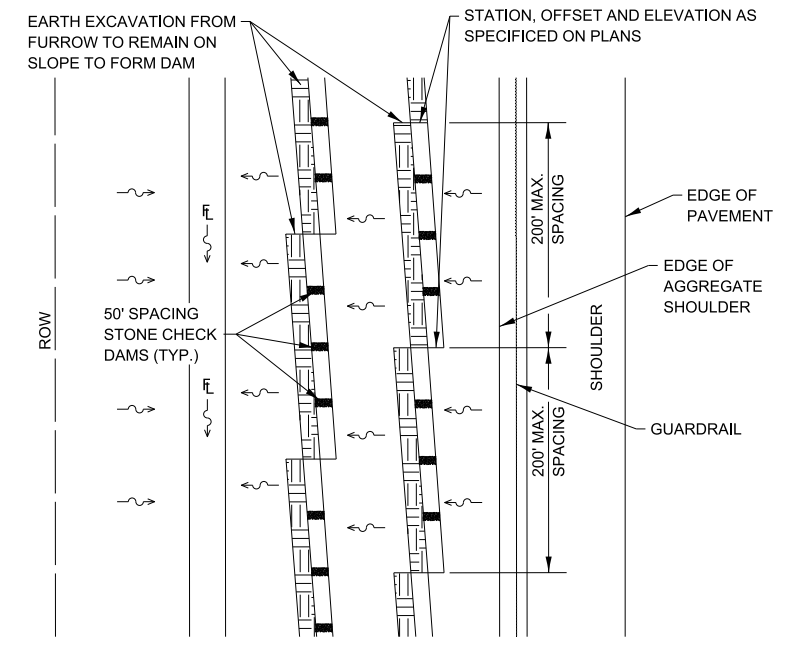

**SHIELDED LOCATIONS**  
PLAN VIEW: NOT TO SCALE

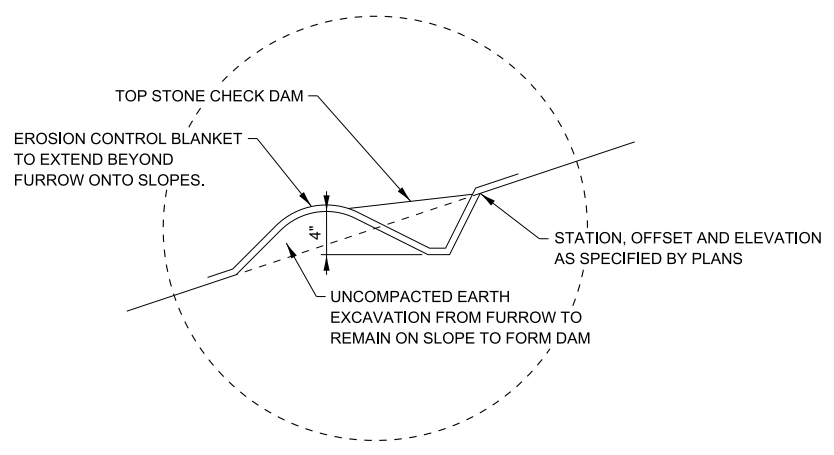
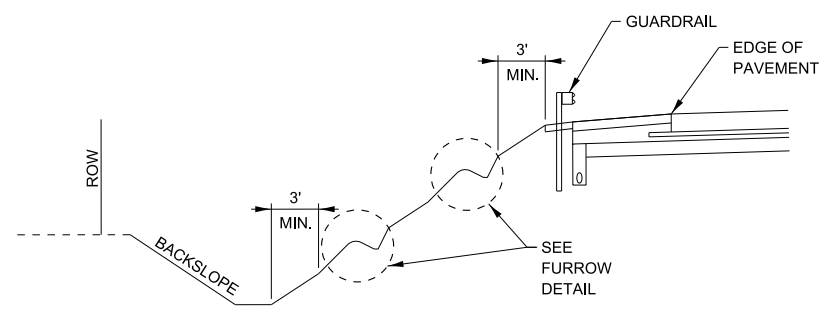
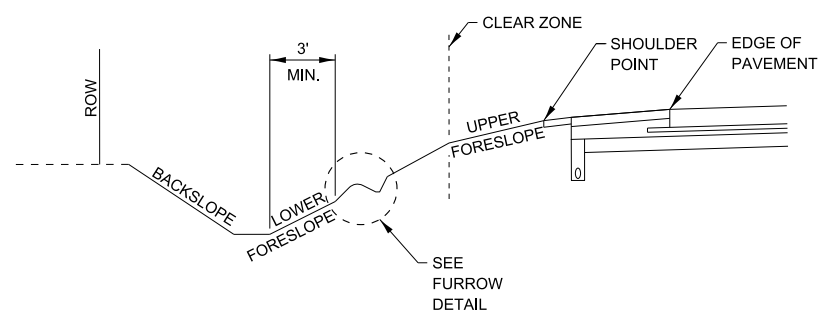

**FURROW DETAIL**  
SECTION VIEW: NOT TO SCALE

**NOTES:**

1. INSTALL STONE CHECK DAMS AT 50' SPACING ALONG FURROW. STONE CHECK DAMS TO CONSIST OF CA-7 STONE, 2' LONG, FILLED TO FULL DEPTH OF FURROW
2. FURROW TO BE SLICED/TILLED ALONG LEVEL CONTOUR BEGINNING.
3. FURROWS SHALL NOT BE INSTALLED IN UNSHIELDED, UNDEFINED CLEAR ZONE LOCATIONS.

REVISIONS	
DATE	DESCRIPTION



**FURROW DETAIL**

VERSION: 2024-03	STANDARD: B31-00	SHEET: 1 OF 1
---------------------	---------------------	------------------

APPROVED BY: *Manar Nashif*  
CHIEF ENGINEERING OFFICER

DATE: 03/01/2024

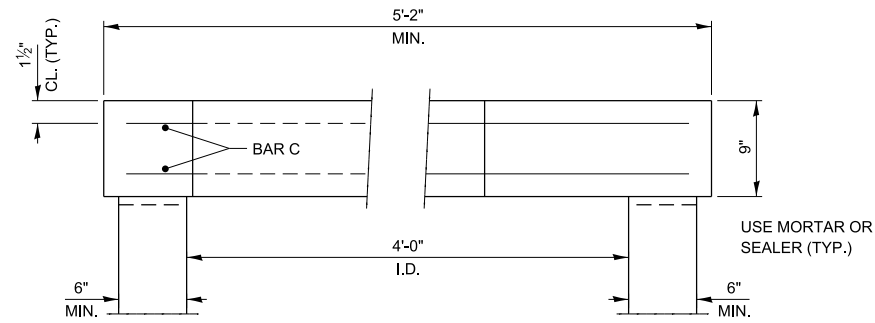

SECTION A-A

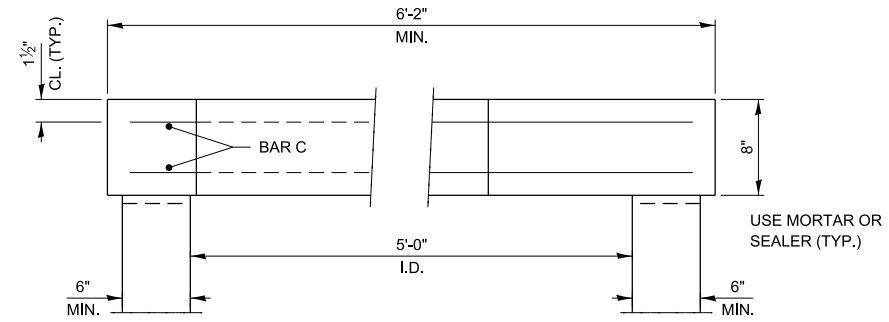

SECTION B-B

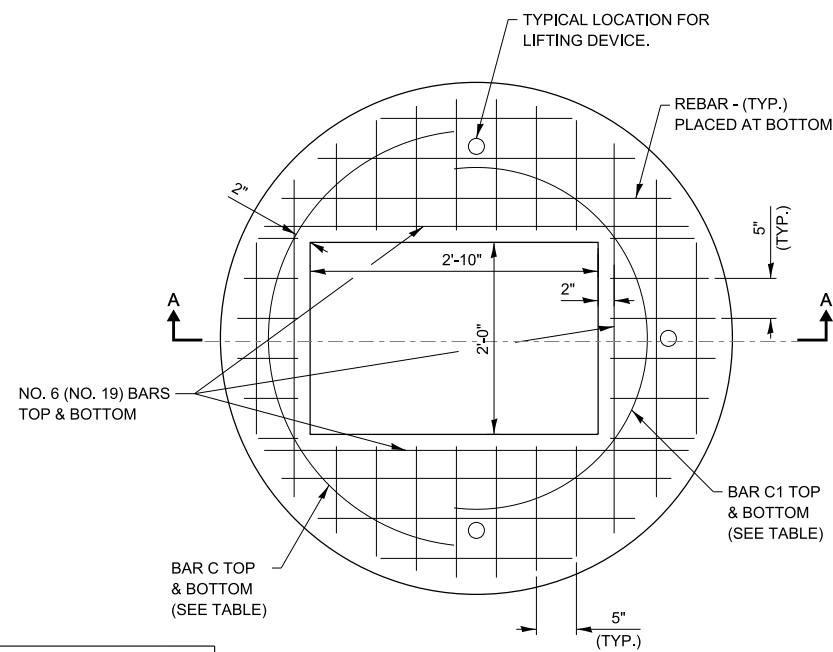

4' MANHOLE PLAN  
SHOWING REBAR REINFORCEMENT  
NO. 6 (NO. 19) UNLESS OTHERWISE SHOWN

NO. 4 (NO. 13)		
BAR	LENGTH	RADIUS
C	6'-6"	2'-2"
C1	6'-6"	1'-10"

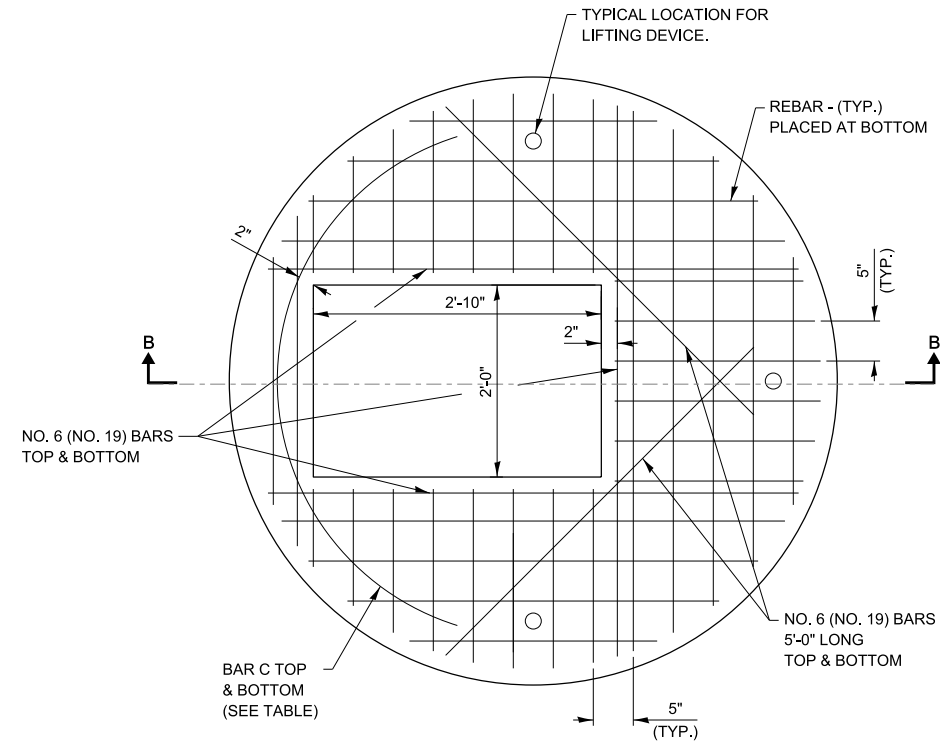

5' MANHOLE PLAN  
SHOWING REBAR REINFORCEMENT  
NO. 6 (NO. 19) UNLESS OTHERWISE SHOWN

NO. 4 (NO. 13) BAR C	
LENGTH	RADIUS
7'-0"	2'-6"



FLAT SLAB TOP FOR TYPE  
G-3 FRAME AND GRATE  
4'-5'-6'-7'-8'-9' DIAMETER

REVISIONS	
DATE	DESCRIPTION
03-01-2024	RENAMED STANDARD
03-01-2022	REVISED SLAB THICKNESS AND REBAR SPACING

APPROVED BY: *Manar Nashif*  
CHIEF ENGINEERING OFFICER      DATE: 03/01/2024

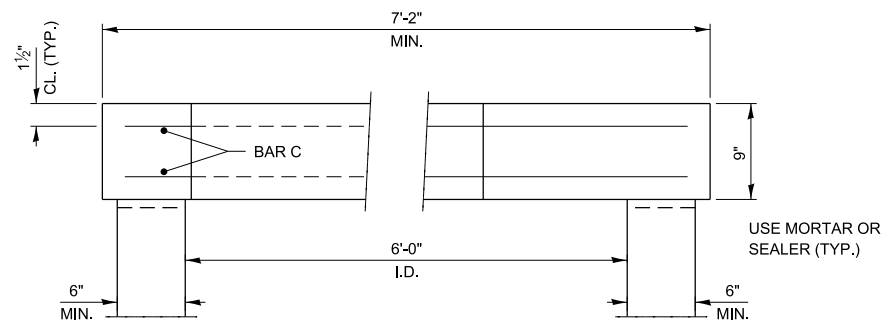

SECTION A-A

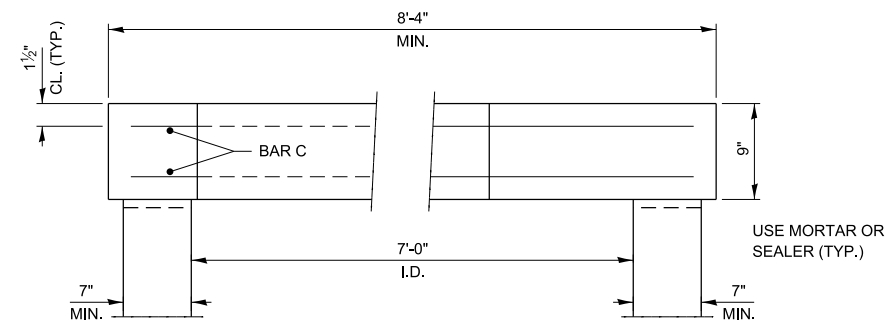

SECTION B-B

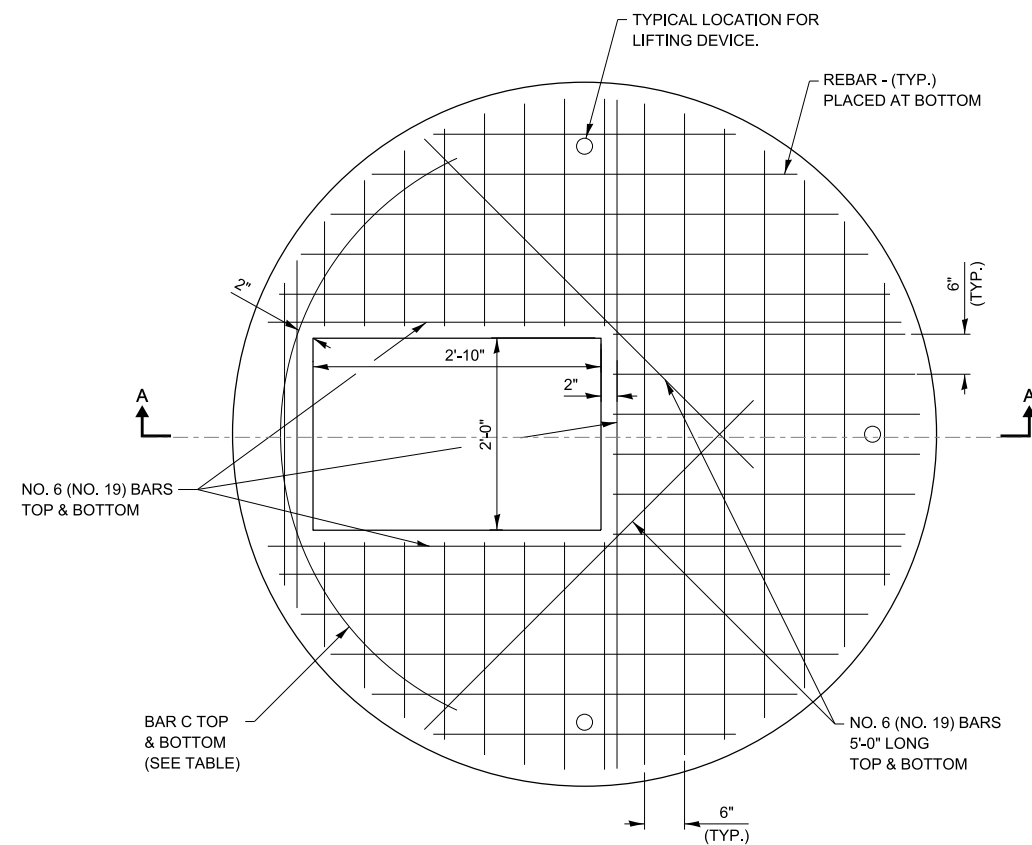

6' MANHOLE PLAN  
SHOWING REBAR REINFORCEMENT  
NO. 6 (NO. 19) UNLESS OTHERWISE SHOWN

NO. 4 (NO. 13) BAR C	
LENGTH	RADIUS
7'-6"	3'-2"

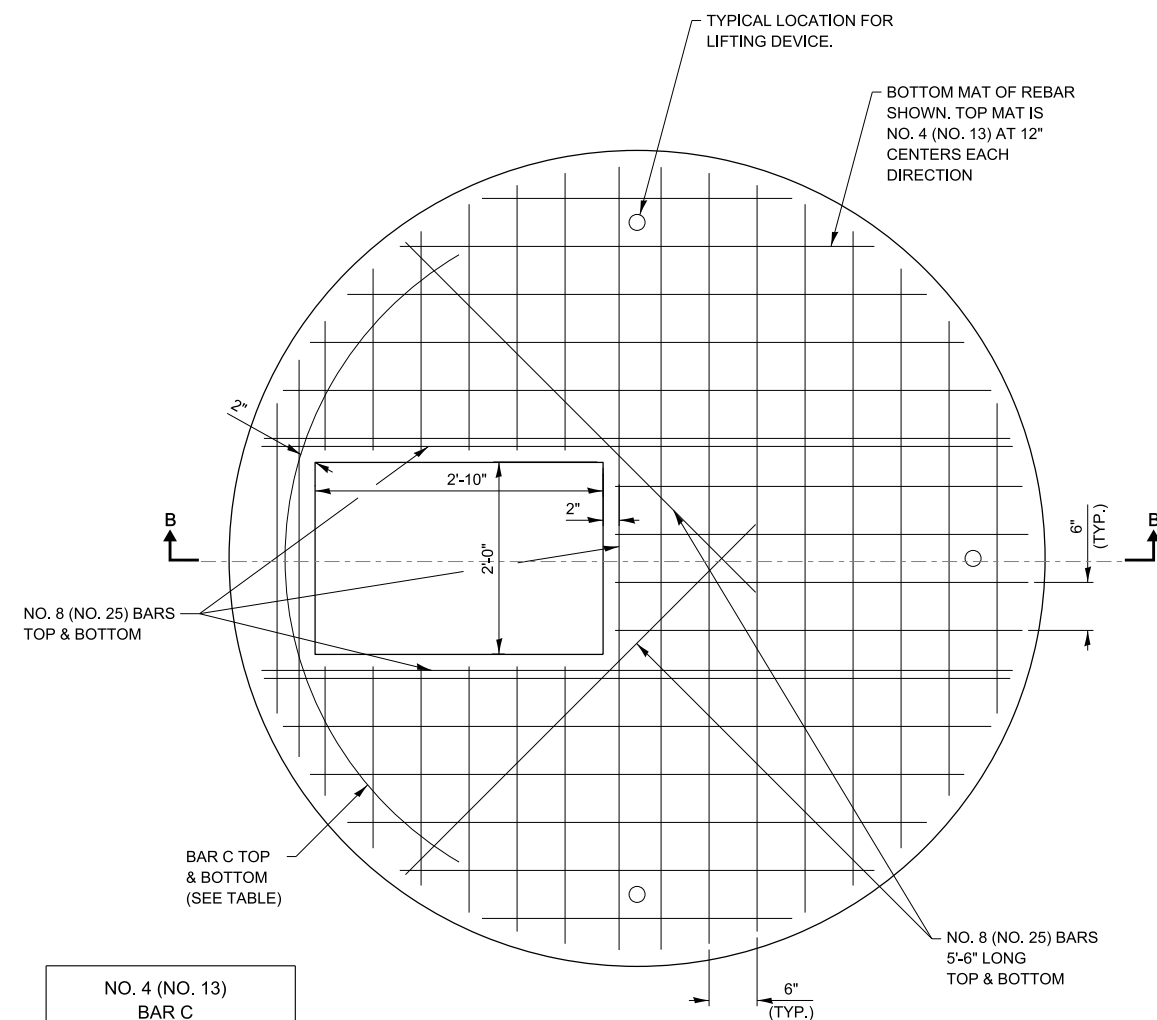

7' MANHOLE PLAN  
SHOWING REBAR REINFORCEMENT  
NO. 8 (NO. 25) UNLESS OTHERWISE SHOWN

NO. 4 (NO. 13) BAR C	
LENGTH	RADIUS
8'-0"	3'-8"

APPROVED BY: *Manar Nashif* DATE: 03/01/2024  
CHIEF ENGINEERING OFFICER



FLAT SLAB TOP FOR TYPE  
G-3 FRAME AND GRATE  
4'-5'-6'-7'-8'-9' DIAMETER

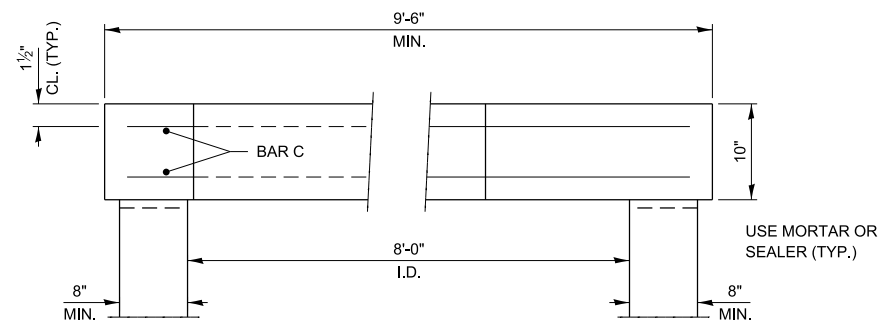

SECTION A-A

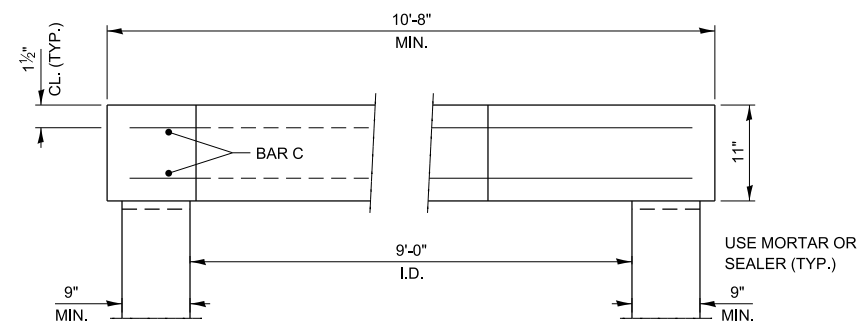

SECTION B-B

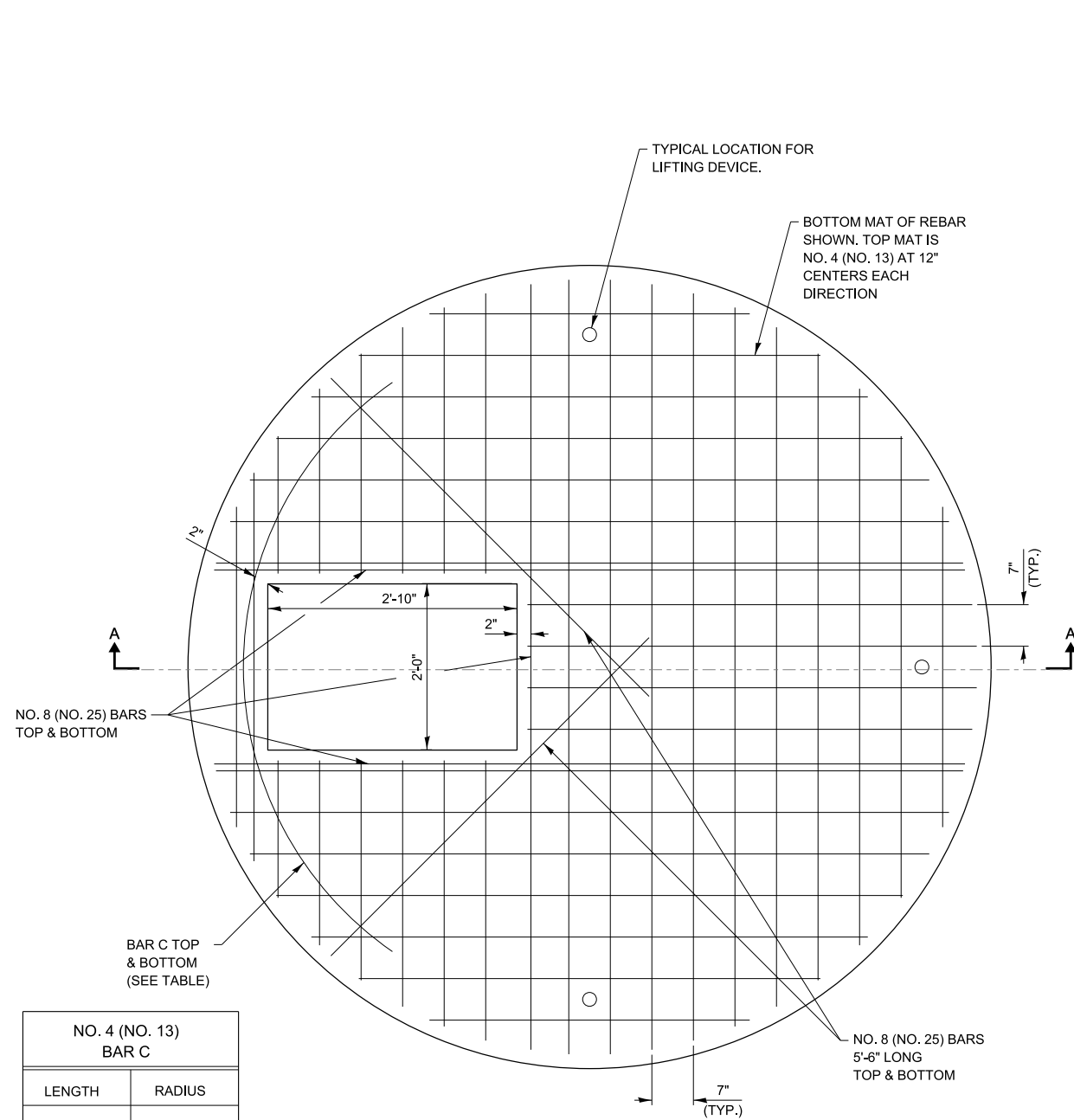

8' MANHOLE PLAN  
SHOWING REBAR REINFORCEMENT  
NO. 8 (NO. 25) UNLESS OTHERWISE SHOWN

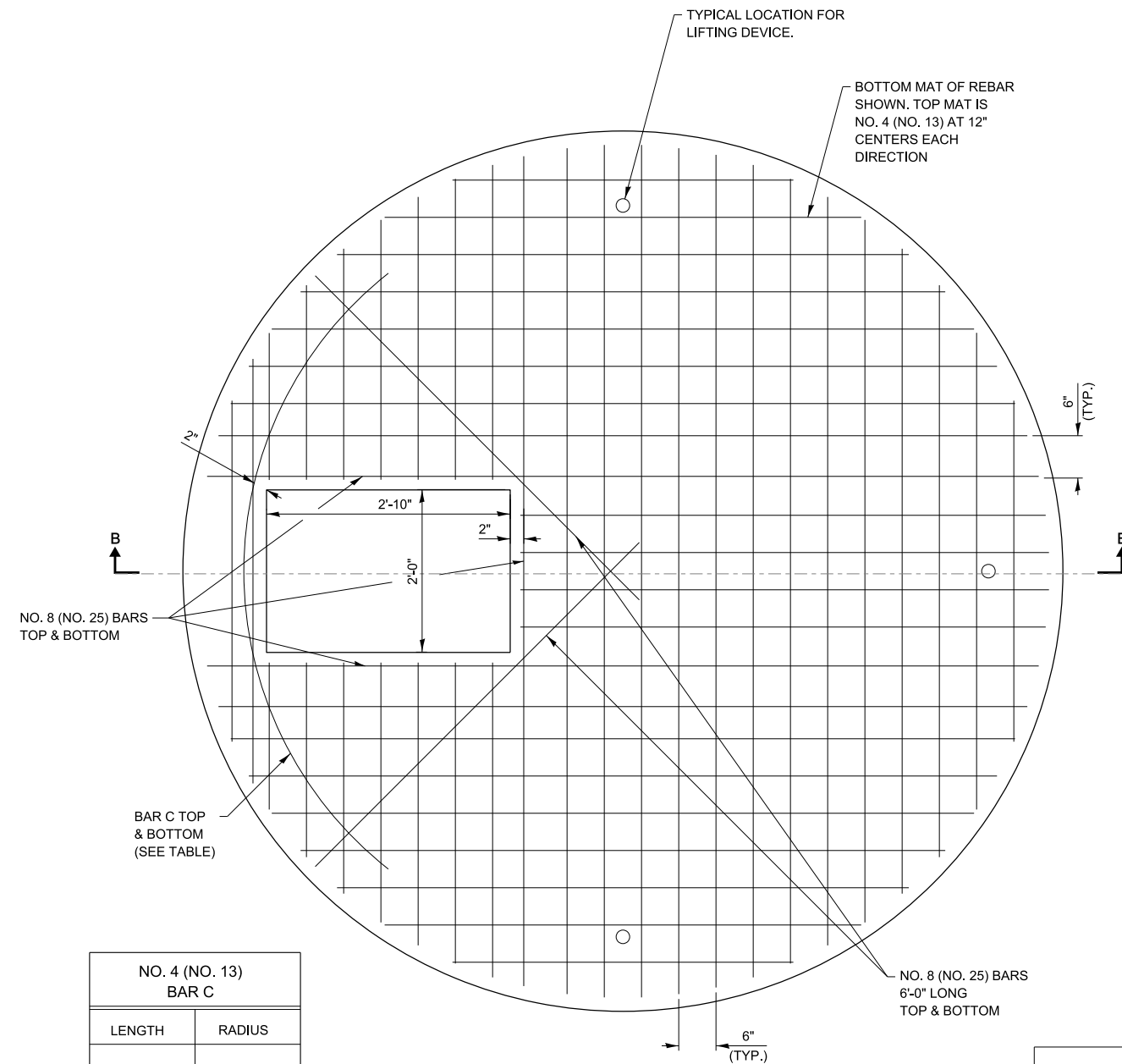

9' MANHOLE PLAN  
SHOWING REBAR REINFORCEMENT  
NO. 8 (NO. 25) UNLESS OTHERWISE SHOWN

NO. 4 (NO. 13) BAR C	
LENGTH	RADIUS
8'-6"	4'-2"

NO. 4 (NO. 13) BAR C	
LENGTH	RADIUS
8'-6"	4'-8"

APPROVED BY: *Manar Nashif*  
CHIEF ENGINEERING OFFICER  
DATE: 03/01/2024



FLAT SLAB TOP FOR TYPE  
G-3 FRAME AND GRATE  
4'-5'-6'-7'-8'-9' DIAMETER